

## Operation Manual

5VP Series Cabinet – Rev 1.3 P/N 160912-10

---

# 5VP Series Programmable DC Load

---



## ADAPTIVE Power Systems

Worldwide Supplier of Power Equipment

Copyright © 2014, Adaptive Power Systems, Inc. (APS) • All Rights Reserved • No reproduction without written authorization from APS.

PAGE LEFT INTENTIONALLY LEFT BLANK FOR HARDCOPY VERSIONS OF THIS DOCUMENT

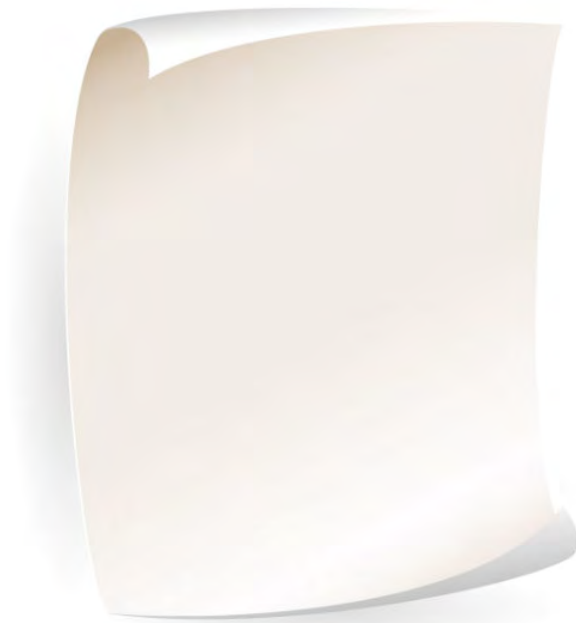

## Table of Contents

<b>1</b>	<b>Contact Information .....</b>	<b>10</b>
<b>2</b>	<b>Front Matter .....</b>	<b>11</b>
2.1	Limited Warranty .....	11
2.2	Service and Spare Parts Limited Warranty .....	11
2.3	Safety Information.....	11
2.4	Safety Notices .....	13
<b>3</b>	<b>Product Overview .....</b>	<b>15</b>
3.1	General Description.....	15
3.2	Operating Modes .....	15
3.2.1	Constant Current Mode .....	15
3.2.2	Constant Resistance Mode .....	16
3.2.3	Constant Voltage Mode .....	16
3.2.4	Constant Power Mode .....	16
3.2.5	Constant Current + Constant Voltage Mode.....	16
3.2.6	Constant Power + Constant Voltage Mode.....	18
3.3	Static versus Dynamic Operating Modes .....	19
3.3.1	Programmable Parameters.....	19
3.3.2	Slew Rates .....	20
3.3.3	Determining Actual Transition Times .....	21
3.4	Battery Discharge Protocols.....	23
3.4.1	BATTERY TYPE1 Test Description.....	23
3.4.2	BATTERY TYPE2 Test Description.....	24
3.4.3	BATTERY TYPE3 Test Description.....	25
3.4.4	BATTERY TYPE4 Test Description.....	26
3.4.5	BATTERY TYPE5 Test Description.....	27
3.5	Current Read-back.....	28
3.6	Analog Input Mode .....	28
3.7	Product Features .....	28
3.8	Accessories Included .....	29
3.9	Interface Options.....	29
3.10	Load Cable Options .....	29
<b>4</b>	<b>Technical Specifications .....</b>	<b>30</b>
4.1	Operating Ranges .....	30
4.2	Operating Modes .....	31
4.3	Protection Modes.....	34
4.4	Dynamic Operation Mode .....	35
4.5	Metering .....	36
4.6	Miscellaneous .....	39
4.7	AC Input & Cooling .....	40
4.8	Dimensions & Weight .....	41
4.9	Detailed Chassis Dimensions .....	42
4.10	Environmental .....	45
4.11	Voltage versus Current Operating Envelope Charts.....	45
4.11.1	Model 5VP05-100 V-I Curves .....	46
4.11.2	Model 5VP10-100 V-I Curves .....	47
4.11.3	Model 5VP15-100 V-I Curves .....	48
4.11.4	Model 5VP20-100 V-I Curves .....	49
4.11.5	Model 5VP25-100 V-I Curves .....	50
4.11.6	Model 5VP30-100 V-I Curves .....	51

4.11.7	Model 5VP05-16 V-I Curves .....	52
4.11.8	Model 5VP10-32 V-I Curves .....	53
4.11.9	Model 5VP15-48 V-I Curves .....	54
4.11.10	Model 5VP20-64 V-I Curves .....	55
4.11.11	Model 5VP25-80 V-I Curves .....	56
4.11.12	Model 5VP30-96 V-I Curves .....	57
4.11.13	Model 5VP40-128 V-I Curves .....	58
4.11.14	Model 5VP50-21 V-I Curves .....	59
4.11.15	Model 5VP60-24 V-I Curves .....	60
4.11.16	Model 5VP05-05 V-I Curves .....	61
4.11.17	Model 5VP10-10 V-I Curves .....	62
4.11.18	Model 5VP15-15 V-I Curves .....	63
4.11.19	Model 5VP20-20 V-I Curves .....	64
4.11.20	Model 5VP25-25 V-I Curves .....	65
4.11.21	Model 5VP30-30 V-I Curves .....	66
4.11.22	Model 5VP35-35 V-I Curves .....	67
4.11.23	Model 5VP40-40 V-I Curves .....	68
4.11.24	Model 5VP50-50 V-I Curves .....	69
4.11.25	Model 5VP60-60 V-I Curves .....	70
<b>5</b>	<b>Unpacking and Installation .....</b>	<b>71</b>
5.1	Inspection .....	71
5.2	Check Line Voltage .....	71
5.3	Input Fuse .....	72
5.4	Grounding Requirements .....	73
5.5	Cleaning.....	73
5.6	Powering Up .....	73
5.7	In Case of Malfunction .....	74
5.8	Load Connection.....	74
5.9	Interface Options.....	76
5.9.1	RS232 Serial Interface.....	76
5.9.2	GPIB Interface .....	76
5.9.3	USB Interface .....	77
5.9.4	LAN Interface .....	77
5.9.5	GPIB & RS232 Combination Interface .....	77
5.10	Analog Programming Input.....	78
5.11	Remote Controller Interface.....	79
5.12	Emergency Stop.....	80
5.13	Load Current Slew Rate.....	81
<b>6</b>	<b>Front Panel Operation .....</b>	<b>83</b>
6.1	Front Panel Layout .....	83
6.2	User Controls and Readouts .....	84
6.2.1	Front Panel Overview .....	84
6.2.2	Displays and Annunciators .....	85
6.2.3	Keyboard Overview .....	88
6.2.4	System Keys and Numeric Entry Keys .....	88
6.2.5	Function Keys .....	94
6.2.6	Test Setting Keys.....	119
6.2.7	Data Entry – Shuttle, Cursor Keys and Keypad .....	134
6.3	Go/NoGo LIMIT Testing .....	137
6.3.1	Limits .....	137
6.3.2	Go/NoGo Testing in CC Mode.....	137
6.3.3	Go/NoGo Testing in CC Dynamic Mode .....	138
6.3.4	Go/NoGo Testing in CR Mode.....	138

6.3.5	Go/NoGo Testing in CV Mode .....	139
6.3.6	Go/NoGo Testing in CP Mode.....	139
6.4	Initial Power-on Settings .....	140
6.4.1	Model 5VP05-100 Power-on Settings .....	140
6.4.2	Model 5VP10-100 Power-on Settings .....	140
6.4.3	Model 5VP15-100 Power-on Settings .....	141
6.4.4	Model 5VP20-100 Power-on Settings .....	141
6.4.5	Model 5VP25-100 Power-on Settings .....	142
6.4.6	Model 5VP30-100 Power-on Settings .....	142
6.4.7	Model 5VP05-16 Power-on Settings .....	143
6.4.8	Model 5VP10-32 Power-on Settings .....	143
6.4.9	Model 5VP15-48 Power-on Settings .....	144
6.4.10	Model 5VP20-64 Power-on Settings .....	144
6.4.11	Model 5VP25-80 Power-on Settings .....	145
6.4.12	Model 5VP30-96 Power-on Settings .....	145
6.4.13	Model 5VP40-128 Power-on Settings .....	146
6.4.14	Model 5VP50-21 Power-on Settings .....	146
6.4.15	Model 5VP60-24 Power-on Settings .....	147
6.4.16	Model 5VP05-05 Power-on Settings .....	147
6.4.17	Model 5VP10-10 Power-on Settings .....	148
6.4.18	Model 5VP15-15 Power-on Settings .....	148
6.4.19	Model 5VP20-20 Power-on Settings .....	149
6.4.20	Model 5VP25-25 Power-on Settings .....	149
6.4.21	Model 5VP30-30 Power-on Settings .....	150
6.4.22	Model 5VP35-35 Power-on Settings .....	150
6.4.23	Model 5VP40-40 Power-on Settings .....	151
6.4.24	Model 5VP50-50 Power-on Settings .....	151
6.4.25	Model 5VP60-60 Power-on Settings .....	152
<b>7</b>	<b>Rear Panel Overview, Connectors and Protection Features.....</b>	<b>153</b>
7.1	DC INPUT Terminals .....	154
7.1.1	Wire Size.....	154
7.1.2	Connecting a UUT.....	154
7.1.3	Polarity and Ground .....	155
7.2	Voltage Sense Input Terminals .....	156
7.3	Current Output Monitor (I-Monitor).....	157
7.3.1	Non-Isolated Output .....	157
7.3.2	Output Impedance .....	158
7.3.3	Connecting I-Monitor Output to an Oscilloscope.....	159
7.4	Parallel Operation.....	160
7.4.1	Parallel Mode Connection.....	160
7.4.2	Allowable Operating Modes .....	160
7.4.3	Exceptions .....	161
7.5	Series Operation .....	161
7.6	Zero-Voltage Loading .....	162
7.7	Protection Features.....	163
7.7.1	Over Voltage Protection.....	163
7.7.2	Over Current Protection.....	163
7.7.3	Over Power Protection.....	163
7.7.4	Over Temperature Protection .....	164
7.7.5	Reverse Polarity Protection Indication .....	164
<b>8</b>	<b>Remote Control Programming.....</b>	<b>165</b>
8.1	Overview .....	165
8.2	RS232 Set-up.....	166

8.3	Programming Syntax.....	167
8.3.1	Parenthesis.....	167
8.3.2	Terminators.....	168
8.4	Short Form Command Syntax.....	169
8.4.1	Notations and Conventions Used in programming commands: .....	173
8.5	Long Form Command Syntax.....	173
8.6	Remote Control Command Descriptions .....	177
8.6.1	SETTING Commands.....	178
8.6.2	LIMIT Commands.....	186
8.6.3	STATE Commands.....	188
8.6.4	SYSTEM Commands .....	193
8.6.5	MEASUREMENT Commands.....	196
8.6.1	AUTO SEQUENCE Commands.....	197
8.6.2	BATTERY TEST Commands .....	199
8.7	IEEE488.2 Common Commands.....	202
8.7.1	*IDN?.....	202
8.7.2	*RST .....	202
<b>9</b>	<b>USB Driver Installation.....</b>	<b>203</b>
9.1	Overview .....	203
9.2	USB Driver Installation .....	203
<b>10</b>	<b>LAN Driver Installation.....</b>	<b>206</b>
10.1	Overview .....	206
10.2	Introduction .....	206
<b>11</b>	<b>Auto Sequence Programming Examples .....</b>	<b>208</b>
11.1	Overview .....	208
11.2	Edit Mode .....	208
11.3	Test Mode .....	209
11.4	AUTO TEST SEQUENCE Example .....	210
<b>12</b>	<b>Short Circuit, OPP and OCP Test Examples .....</b>	<b>211</b>
12.1	Overview .....	211
12.2	OCP Test Example.....	211
12.2.1	OCP Test – Remote Control .....	214
12.3	OPP Test Example.....	215
12.3.1	OPP Test – Remote Control .....	218
12.4	SHORT Test Example .....	219
12.4.1	SHORT Test – Remote Control .....	221
<b>13</b>	<b>CE MARK Declaration of Conformity.....</b>	<b>222</b>
<b>14</b>	<b>RoHS Material Content Declaration.....</b>	<b>223</b>
	<b>Index .....</b>	<b>223</b>

## Table of Tables

Table 3-1: Dynamic Current Mode Parameters.....	19
Table 3-2: Available Built-in Battery Test Modes .....	23
Table 3-3: Included Accessories .....	29
Table 3-4: Available Remote Control Interface Options.....	29
Table 3-5: Available Load Cable Options .....	29
Table 6-1: Model 5VP05-100 Power-on Settings.....	140
Table 6-2: Model 5VP10-100 Power-on Settings.....	140
Table 6-3: Model 5VP15-100 Power-on Settings.....	141
Table 6-4: Model 5VP20-100 Power-on Settings.....	141
Table 6-5: Model 5VP25-100 Power-on Settings.....	142
Table 6-6: Model 5VP30-100 Power-on Settings.....	142
Table 6-7: Model 5VP05-16 Power-on Settings.....	143
Table 6-8: Model 5VP10-32 Power-on Settings.....	143
Table 6-9: Model 5VP15-48 Power-on Settings.....	144
Table 6-10: Model 5VP20-64 Power-on Settings.....	144
Table 6-11: Model 5VP25-80 Power-on Settings.....	145
Table 6-12: Model 5VP30-96 Power-on Settings.....	145
Table 6-13: Model 5VP40-128 Power-on Settings.....	146
Table 6-14: Model 5VP50-21 Power-on Settings.....	146
Table 6-15: Model 5VP60-24 Power-on Settings.....	147
Table 6-16: Model 5VP05-05 Power-on Settings.....	147
Table 6-17: Model 5VP10-10 Power-on Settings.....	148
Table 6-18: Model 5VP15-15 Power-on Settings.....	148
Table 6-19: Model 5VP20-20 Power-on Settings.....	149
Table 6-20: Model 5VP25-25 Power-on Settings.....	149
Table 6-21: Model 5VP30-30 Power-on Settings.....	150
Table 6-22: Model 5VP35-35 Power-on Settings.....	150
Table 6-23: Model 5VP40-40 Power-on Settings.....	151
Table 6-24: Model 5VP50-50 Power-on Settings.....	151
Table 6-25: Model 5VP60-60 Power-on Settings.....	152
Table 8-1: RS232 DB9 Pin Assignments .....	166
Table 8-2: Supported Command Terminators .....	168
Table 8-3: Setting Commands - Short Form .....	169
Table 8-4: Query Commands - Short Form .....	170
Table 8-5: Limit Commands - Short Form .....	170
Table 8-6: State Commands - Short Form .....	171
Table 8-7: System Commands - Short Form .....	171
Table 8-8: Measurement Query Commands - Short Form .....	172
Table 8-9: Auto Sequence Commands - Short Form .....	172
Table 8-10: Battery Test Commands – Short Form .....	172
Table 8-11: Setting Commands - Long Form .....	173
Table 8-12: Query Commands - Long Form.....	174
Table 8-13: Limit Commands - Long Form.....	174
Table 8-14: State Commands - Long Form .....	175

---

Table 8-15: System Commands - Long Form .....	175
Table 8-16: Measurement Query Commands .....	176
Table 8-17: Auto Sequence Commands - Long Form .....	176
Table 8-18: Battery Test Commands – Same as Short Form .....	176
Table 8-19: Error Register Bits .....	190
Table 8-20: Protection Status Register Bits .....	191
Table 8-21: 5VP Series Cabinet Load Model Name Return Values .....	194
Table 11-1: Auto-Test Sequence Example Values .....	210

## Table of Figures

Figure 3-1: CC+CV Mode of Operation .....	17
Figure 3-2: CP+CV Mode of Operation .....	18
Figure 3-3: Dynamic Current Wave Form .....	19
Figure 3-4: Rise Time Performance Limits .....	20
Figure 3-5: Battery TYPE1 Test Protocol Illustration .....	23
Figure 3-6: Battery TYPE2 Test Protocol Illustration .....	24
Figure 3-7: Battery TYPE3 Test Protocol Illustration .....	25
Figure 3-8: Battery TYPE4 Test Protocol Illustration .....	26
Figure 3-9: Battery TYPE5 Test Protocol Illustration .....	27
Figure 4-1: 5VP Series Cabinet Dimensions- Small .....	43
Figure 4-2: 5VP Series Cabinet Dimensions- Large .....	44
Figure 4-1: Model 5L18-36 VI Curve .....	71
Figure 5-2: AC Input Rating Label and Terminal Locations .....	71
Figure 5-3: RS232 Connection .....	76
Figure 5-4: GPIB Connection .....	76
Figure 5-5: USB Connection .....	77
Figure 5-6 LAN Connection .....	77
Figure 5-7: RS232 Connection .....	77
Figure 5-8: Location of Analog Programming Input Connector on 5VP Unit.....	78
Figure 5-9: Analog Programming Input Example.....	78
Figure 5-10: Remote Controller Connection .....	79
Figure 5-11: Effect of Current Slew Rate Settings on Power Supply Testing.....	82
Figure 6-1: 5VP Series DC Load Front Panel View .....	83
Figure 6-2: Front Panel User Controls and Indicators .....	84
Figure 6-3: LCD Displays Segments and Annunciators .....	85
Figure 6-4: DYN Setting Parameter Setting Screens .....	96
Figure 6-5: Configuration Menu Sequence.....	105
Figure 6-6: AUTO SEQUENCE EDIT Mode Flow Chart .....	115
Figure 6-7: AUTO SEQUENCE TEST Mode Flow Chart.....	118
Figure 6-8: LIMIT Test in CC Mode.....	137
Figure 6-9: LIMIT Test in Dynamic CC Mode.....	138
Figure 6-10: LIMIT Test in CR Mode .....	138
Figure 6-11: LIMIT Test in CV Mode .....	139
Figure 6-12: LIMIT Test in CP Mode.....	139
Figure 7-1: Rear Panel Connector Locations.....	153
Figure 7-2: DC Load Connections with Internal or External Voltage Sense .....	156
Figure 7-3: Equivalent I-Monitor Output Circuit .....	158
Figure 7-4: Correct I-Monitor Connections to UUT and Oscilloscope .....	159
Figure 7-5: Incorrect I-Monitor Connections to UUT and Oscilloscope.....	159
Figure 7-6: Parallel Load Connection.....	160
Figure 7-7: Zero Volt Load Connection .....	162
Figure 8-1: RS232 Connection to PC and DB9 Pin out .....	166
Figure 11-1 Auto-Test Sequence Example Illustration .....	210

## 1 Contact Information

### AMERICA / CANADA

Adaptive Power Systems  
Irvine, USA  
Phone: +1(949) 752-8400  
Fax: +1 (949) 756-0838  
Email: [support@adaptivepower.com](mailto:support@adaptivepower.com)

### EUROPE

Caltest Instruments Ltd.  
Guildford, United Kingdom  
Phone: +44(0)1483 302 700  
Fax: +44(0)1483 300 562  
Email: [support@adaptivepower.com](mailto:support@adaptivepower.com)

### CHINA

PPST Shanghai Co. Ltd.  
Shanghai, China  
Phone: +86-21-6763-9223  
Fax: +86-21-5763-8240  
Email: [support@adaptivepower.com](mailto:support@adaptivepower.com)

Web: <http://www.adaptivepower.com>

## 2 Front Matter

### 2.1 Limited Warranty

Adaptive Power Systems, Inc. (APS) warrants each unit to be free from defects in material and workmanship. For the period of one (1) year from the date of shipment to the purchaser, APS will either repair or replace, at its sole discretion, any unit returned to the APS factory in Irvine, California or one of its designated service facilities. It does not cover damage arising from misuse of the unit or attempted field modifications or repairs. This warranty specifically excludes damage to other equipment connected to this unit.

Upon notice from the purchaser within (30) days of shipment of units found to be defective in material or workmanship, APS will pay all shipping charges for the repair or replacement. If notice is received more than thirty (30) days from shipment, all shipping charges shall be paid by the purchaser. Units returned on debit memos will not be accepted and will be returned without repair.

**This warranty is exclusive of all other warranties, expressed or implied.**

### 2.2 Service and Spare Parts Limited Warranty

APS warrants repair work to be free from defects in material and workmanship for the period of ninety (90) days from the invoice date. This Service and Spare Parts Limited Warranty applies to replacement parts or to subassemblies only. All shipping and packaging charges are the sole responsibility of the buyer. APS will not accept debit memos for returned power sources or for subassemblies. Debit memos will cause return of power sources or assemblies without repair.

**This warranty is exclusive of all other warranties, expressed or implied.**

### 2.3 Safety Information

This chapter contains important information you should read BEFORE attempting to install and power-up APS Equipment. The information in this chapter is provided for use by experienced operators. Experienced operators understand the necessity of becoming familiar with, and then observing, life-critical safety and installation issues. Topics in this chapter include:

- Safety Notices
- Warnings
- Cautions
- Preparation for Installation
- Installation Instructions



Make sure to familiarize yourself with the **SAFETY SYMBOLS** shown on the next page. These symbols are used throughout this manual and relate to important safety information and issues affecting the end user or operator.

### SAFETY SYMBOLS



Direct current (DC)



Alternating current (AC)



Both direct and alternating current



Three-phase alternating current



Protective Earth (ground) terminal



On (Supply)



Off (Supply)

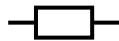

Fuse



Caution: Refer to this manual before this Product.



Caution, risk of electric shock

## 2.4 Safety Notices

### **SAFETY SUMMARY**

The following general safety precautions must be observed during all phases of operation, service, and repair of this instrument. Failure to comply with these precautions or with specific warnings elsewhere in this manual violates safety standards of design, manufacture, and intended use of the instrument. Adaptive Power Systems assumes no liability for the customer's failure to comply with these requirements.

### **GENERAL**

This product is a Safety Class 1 instrument (provided with a protective earth terminal). The protective features of this product may be impaired if it is used in a manner not specified in the operation instructions.

### **ENVIRONMENTAL CONDITIONS**

This instrument is intended for indoor use in an installation category I, pollution degree 2 environments. It is designed to operate at a maximum relative humidity of 80% and at altitudes of up to 2000 meters. Refer to the specifications tables for the ac mains voltage requirements and ambient operating temperature range.

### **BEFORE APPLYING POWER**

Verify that the product is set to match the available line voltage and the correct fuse is installed.

### **GROUND THE INSTRUMENT**

This product is a Safety Class 1 instrument (provided with a protective earth terminal). To minimize shock hazard, the instrument must be connected to an electrical ground. The instrument must be connected to the AC power supply mains through a properly rated three-conductor power cable, with the third wire firmly connected to an electrical ground (safety ground) at the power outlet. Any interruption of the protective (grounding) conductor or disconnection of the protective earth terminal will cause a potential shock hazard that could result in personal injury.

### **FUSES**

Only fuses with the required rated current, voltage, and specified type (normal blow, time delay, etc.) should be used. Do not use repaired Fuses or short circuit the fuse holder. To do so could cause a shock or fire hazard.

### **DO NOT OPERATE IN AN EXPLOSIVE ATMOSPHERE.**

Do not operate the instrument in the presence of flammable gases or fumes.

### **KEEP AWAY FROM LIVE CIRCUITS.**

Operating personnel must not remove instrument covers. Component replacement and internal adjustments must be made by qualified service personnel. Do not replace components with power cable connected. Under certain conditions, dangerous voltages

may exist even with the power cable removed. To avoid injuries, always disconnect power, discharge circuits and remove external voltage sources before touching components.

**DO NOT SERVICE OR ADJUST ALONE.**

Do not attempt internal service or adjustment unless another person, capable of rendering first aid and resuscitation, is present.

**DO NOT EXCEED INPUT RATINGS.**

This instrument may be equipped with a line filter to reduce electromagnetic interference and must be connected to a properly grounded receptacle to minimize electric shock hazard. Operation at line voltages or frequencies in excess of those stated on the data plate may cause leakage currents in excess of 5.0 mA peak.

**DO NOT EXCEED LOAD INPUT VOLTAGE RATING.**

 **WARNING**

**DO NOT EXCEED LOAD INPUT VOLTAGE RATING**

This instrument does **NOT** have a means to disconnect its Load input from a connected power supply. If the voltage applied to the Load input exceeds its maximum rating – even if the load is turned completely off – damage to the load **WILL** occur. Damage caused by exceeded maximum load input voltage under any circumstance is **NOT** covered by the manufacturer’s product warranty. Remove any load input connections when the load is not in use, even when it is turned off.

**DO NOT SUBSTITUTE PARTS OR MODIFY INSTRUMENT.**

Because of the danger of introducing additional hazards, do not install substitute parts or perform any unauthorized modification to the instrument. Return the instrument to an Adaptive Power Systems Sales and Service Office for service and repair to ensure that safety features are maintained.

Instruments that appear damaged or defective should be made inoperative and secured against unintended operation until they can be repaired by qualified service personnel.

## 3 Product Overview

This chapter provides an overview of the APS 5VP Series programmable DC loads. It introduces the reader to general operating characteristics of these loads.

### 3.1 General Description

The APS 5VP Series electronic load is designed to test, evaluation and burn-in DC power supplies and batteries. The APS 5VP Series electronic load consist of floor standing chassis on lockable caster for easy of mobility. The 5VP Series load can be operated from the front panel (manual mode) or using RS232, USB, LAN (Ethernet) or GPIB remote control.

The VI curve constant power contours of the various 5VP Series models are shown in the Technical Specification Section. Three voltage range models are available:

- 60V range
- 600V range
- 1000V range

Maximum current and power capability depends on the specific 5VP model.

### 3.2 Operating Modes

Available operating modes for all models are:

- Constant Current (CC) mode
- Constant Resistance (CR) mode
- Constant Voltage (CV) mode
- Constant Power (CP) mode.

A more detailed explanation of each mode and under what condition each mode is most appropriate to use follows.

#### 3.2.1 Constant Current Mode

This is the most commonly used mode of operating when testing a voltage source such as a DC power supply, battery, AC/DC converter or ADC. In this mode of operation, the load will sink a constant level of current as set by the user, regardless of any voltage variations. A real time feedback loop ensures a stable current under any voltage variation of the DC supply or battery.

This mode is recommended for load regulation testing, loop stability testing, battery discharge testing and any other form of voltage regulation loop testing.

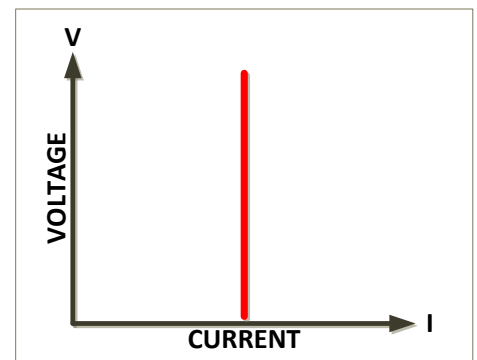

### 3.2.2 Constant Resistance Mode

In Constant Resistance mode, the load will sink current directly proportional to the sensed DC input voltage. The ratio between DC voltage and current is linear per ohms law and can be set by the user within the operating range of the DC load. The current is defined by the formula shown here where R is the set value in CR mode and V is the dc input voltage from the unit under test.

$$I = V/R$$

CR mode is useful for battery discharge testing of battery systems used to power constant impedance loads as the voltage will decrease as the battery discharges over time resulting in reduced current sinking.

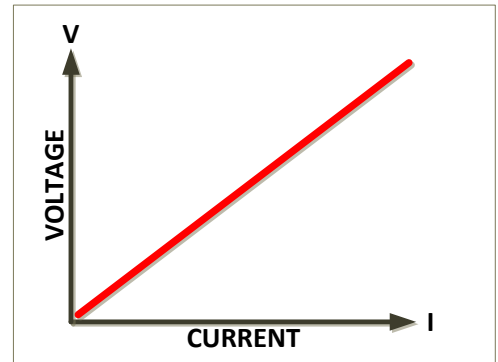

### 3.2.3 Constant Voltage Mode

In Constant Voltage mode, the load will attempt to sink as much current as needed to reach the programmed voltage setting. This mode should only be used with current controlled DC power sources.

**Note:** Most DC power supplies are voltage controlled, i.e. they regulate the output voltage to a predefined voltage level. Such DC voltage supplies should not be tested using CV mode as the DC supply voltage regulation loop will conflict with the DC load control loop.

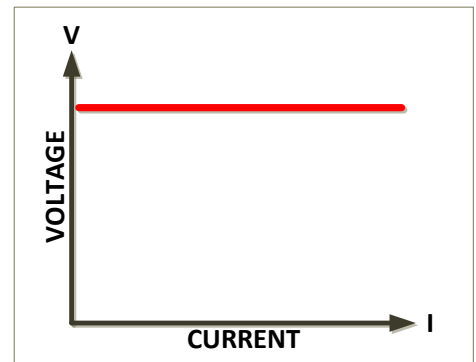

### 3.2.4 Constant Power Mode

In Constant Power mode, the DC load will attempt to maintain the programmed Power dissipation by sinking more or less current at the voltage sensed. The current is defined by the formula shown below.

$$I = P/V$$

Constant power mode is useful for battery discharge testing as it simulates constant power drain on the battery, regardless of battery charge state.

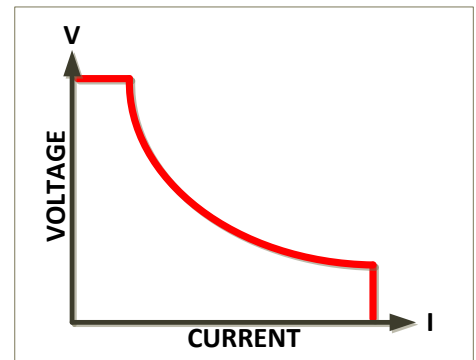

### 3.2.5 Constant Current + Constant Voltage Mode

The CC+CV mode is a combination of the CC and the CV modes and is primarily intended for battery test applications. When the 5VP is used in constant current mode, it is possible to add CV mode as well by selecting the add.CV setting.



This will place the load in CC+CV mode. In this mode, the DC load operates like a shunt regulator as shown in the figure below. Operating as a constant current load, the 5VP sinks the specified CC current setting level regardless of the DC input voltage from the Battery. When the battery voltage (VM) rises above the CV set point level, the DC load reverts to CV mode of operation, keeping the voltage constant by adjusting the dc current as needed. If VM is less than or equal to the CV set point V, no current will flow.

The 5VP will transition between both modes automatically. In the illustration below, R1 is the internal impedance of the battery or other type of constant voltage power supply. Note that while in CV mode, the DC load may be unstable if R1 is very low.

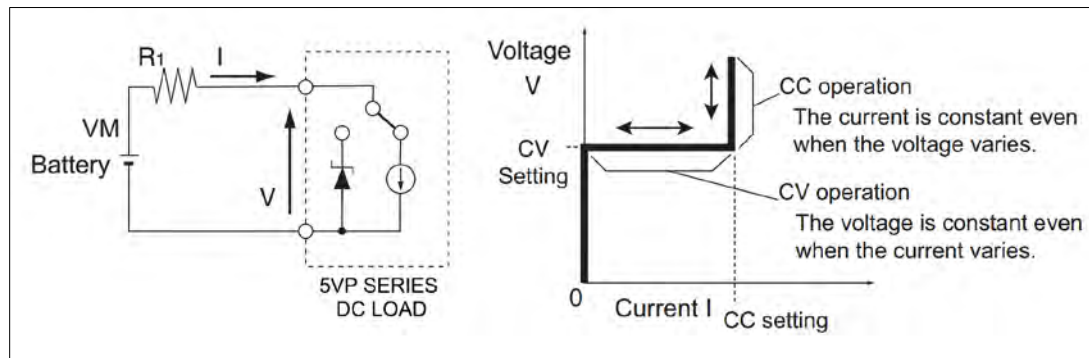

*Figure 3-1: CC+CV Mode of Operation*

### 3.2.6 Constant Power + Constant Voltage Mode

The CP+CV mode is a combination of the CP and the CV modes and is also intended for battery test applications. When the 5VP is used in constant power mode, it is possible to add CV mode as well by selecting the add.CV setting.



This mode operates in a similar fashion as the CC+CV mode but operates in a constant power mode until the power exceeds the power setting at which point the load transitions to constant voltage mode of operation.

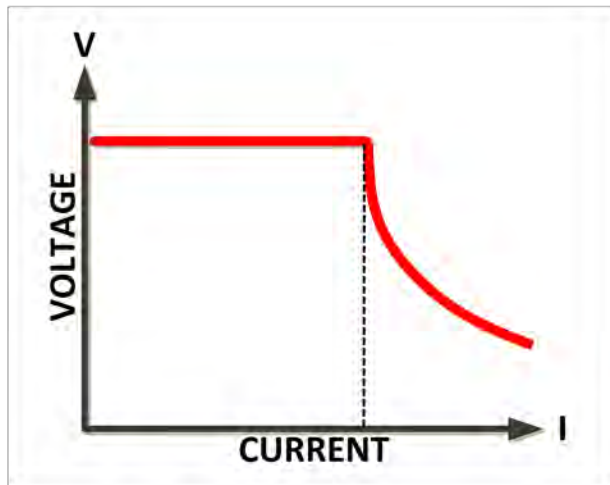

Figure 3-2: CP+CV Mode of Operation

### 3.3 Static versus Dynamic Operating Modes

The 5VP Series supports both STATIC and DYNAMIC CC mode. Static mode uses a constant load level whereas dynamic mode allows rapid changes between two pre-set current sink levels using programmable current slew rates and duty cycle.

Static Constant Current mode presents a static load condition as the load current remains constant. This tests load regulation of a DC power supply under steady state operating conditions.

To test voltage regulation under dynamic load conditions, specific changes in current level and current slew rates must be applied to the DC supply under test. The dynamic CC mode is provided for this application.

The 5VP Series offers a wide range of dynamic load conditions with independent rise and fall current slew rate programming in Constant Current mode.

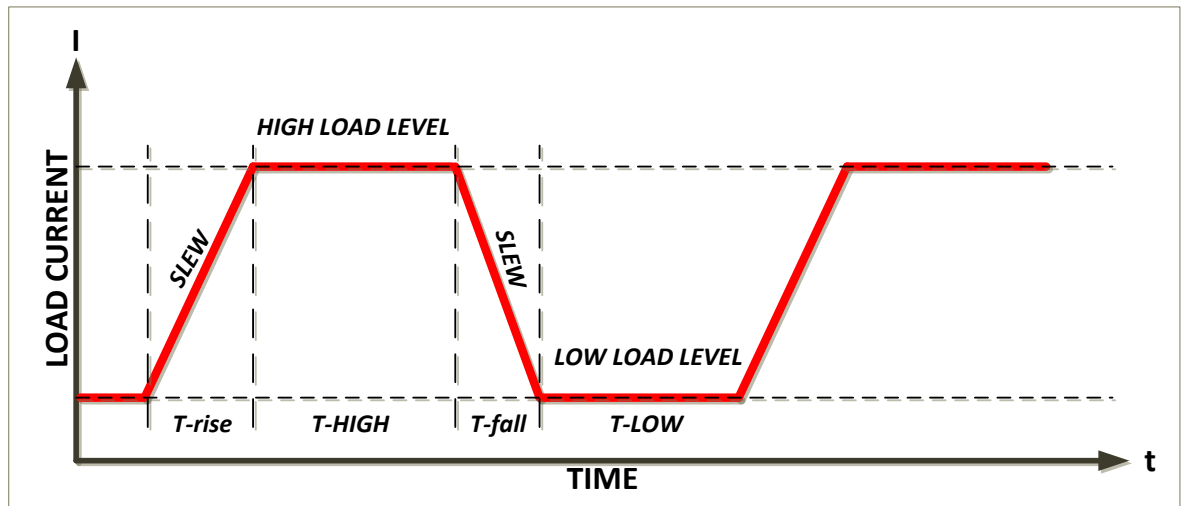

Figure 3-3: Dynamic Current Wave Form

#### 3.3.1 Programmable Parameters

There are six programmable parameters to generate a dynamic waveform or pulse waveform. The 5VP Series load will sink current from a power source proportional to the dynamic wave form. The dynamic wave form definition is shown in Figure 3-1. Available settings are:

Parameter	Description	Type
<b>Current High</b>	Highest programmed load current	Current Setting
<b>Current Low</b>	Lowest programmed load current	Current Setting
<b>T-High</b>	Duration at High current setting	Time (secs)
<b>T-Low</b>	Duration at Low current setting	Time (secs)
<b>Rising Slew Rate</b>	Current Slew Rate from Low to High Current	A/sec
<b>Falling Slew Rate</b>	Current Slew Rate from High to Low Current	A/sec

Table 3-1: Dynamic Current Mode Parameters

The resulting Current Waveform has the following characteristics:

$$\text{Period} = T\text{-High} + T\text{-Low}$$

$$\text{Frequency} = 1 / ( T\text{-High} + T\text{-Low} )$$

$$\text{Duty Cycle} = T\text{-High} / ( T\text{-High} + T\text{-Low} )$$

### 3.3.2 Slew Rates

Slew rate is defined as the change in current or voltage over time. A programmable slew rate allows a controlled transition from one load setting to another to minimize induced voltage drops on inductive power wiring, or to control induced transients on a test device (such as would occur during power supply transient response testing).

In cases where the transition from one setting to another is large, the actual transition time can be calculated by dividing the voltage or current transition by the slew rate. The actual transition time is defined as the time required for the input to change from 10% to 90% or from 90% to 10% of the programmed current excursion. In cases where the transition from one setting to another is small, the small signal bandwidth of the load limits the minimum transition time for all programmable slew rates. Because of this limitation, the actual transition time is typically longer than the expected time based on the slew rate setting, as shown in Figure 3-2.

Therefore, both minimum transition time and slew rate must be considered when determining the actual transition time. *See also section 5.13, "Load Current Slew Rate" on page 81 "*

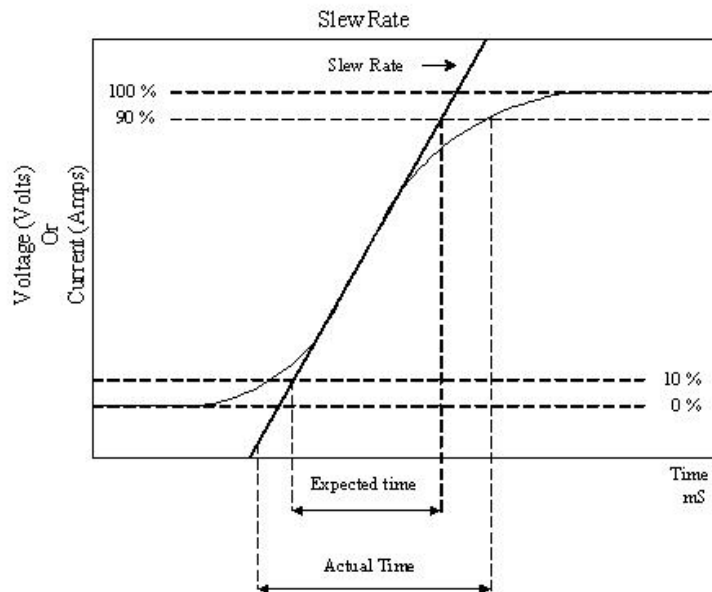

Figure 3-4: Rise Time Performance Limits

### 3.3.3 Determining Actual Transition Times

The minimum transition time ( $Tr_{min}$ ) for a given slew rate applies for smaller changes in current as a percent of current range. At about a 30% or greater load change, the slew rate starts to increase from the minimum transition time to the maximum transition time ( $Tr_{max}$ ) at a 100% load change. The actual transition time will be either the minimum transition time, or the total slew time (T-fall or T-rise) divided by the current slew rate, whichever is longer.

Calculations shown below are for model 5VP10-32 but same formulas apply to other 5VP models.

Model 5VP10-32 has a 320A current range so load changes less than 0.3 x 320A or 96A are at minimum transition time.

#### Minimum $Tr$

Use the following formulas to calculate the minimum transition time for a given slew rate:

$$Tr_{min} = \frac{96}{\text{slew rate (A/s)}} * \frac{(90\% - 10\%)}{100\%} \mu\text{s}$$

Which is equivalent to:

$$Tr_{min} = \frac{96}{\text{slew rate (A/s)}} * 0.8 \mu\text{s}$$

For a slew rate of 16A/s, this results in:

$$Tr_{min} = \frac{96}{16} * 0.8 \mu\text{s} = 4.8 \mu\text{s}$$

#### Example 1:

Assume high current level C-high = 64A and low current level C-low = 0A. 64A represents less than 30% of full scale current for the DC load model used. If the slew rate is set to 15A/s, the expected transition time would be:

$$Tr = \frac{0.8 * (64 - 0)}{16} \mu\text{s} = 3.2 \mu\text{s}$$

However, we determined that  $Tr_{min}$  for a slew rate of 16A/s is at least 4.8  $\mu\text{s}$  so the actual transition time will be limited to no less than 4.8  $\mu\text{s}$ .

**Maximum  $T_r$** 

Use the following formula to calculate the maximum transition time for a given slew rate:

$$T_r \text{ max} = \frac{320}{\text{slew rate (A/s)}} * 0.8 \mu\text{s}$$

For a slew rate of 5A/s, this results in:

$$T_r \text{ max} = \frac{320}{16} * 0.8 \mu\text{s} = 16.0 \mu\text{s}$$

**Example 2:**

Assume high current level C-high = 200A and low current level C-low = 0A. 200A represents more than 30% of the current range for the DC load model used. If the slew rate is set to 16A/s, the expected transition time would be:

$$T_r = \frac{0.8 * (200 - 0)}{16} \mu\text{s} = 10.0 \mu\text{s}$$

Since  $T_r \text{ max}$  for a slew rate of 16A/s is 16.0  $\mu\text{s}$  so the actual transition time will be larger of these two values or 16.0  $\mu\text{s}$ .

### 3.4 Battery Discharge Protocols

The 5VP series features several built-in battery discharge modes than can be selected by the user from the front panel or over one of the digital remote control interface.

Test#	Type	Description	Available
1	Discharge to state of charge and stop	Discharges battery in CC mode using set current level till preset battery end voltage is reached and then load is turned off.	Front Panel Remote
2	Discharge to state of charge and hold	Discharges battery in CC mode using set current level till preset battery end voltage is reached and then switches to CV mode at set voltage.	Front Panel Remote
3	Timed discharge test	Discharges battery in CC mode using set current level for the period of time specified. At end of test time, the load turns off and displays battery voltage.	Front Panel Remote
4	Cycle Life test	Battery is discharged using current pulse mode using programmed sequence.	Remote
5	Ramp Discharge test	Expansion of Life Cycle test using programmed current slew rates between current discharge levels.	Remote

Table 3-2: Available Built-in Battery Test Modes

#### 3.4.1 BATTERY TYPE1 Test Description

Battery TYPE1 mode discharges a battery in constant current (CC) mode using set current level till the battery voltage drops below a preset under voltage protection (UVP) threshold. Once reached, load is turned off so no further discharge occurs. Programmable parameter is the UVP value shown in figure below.

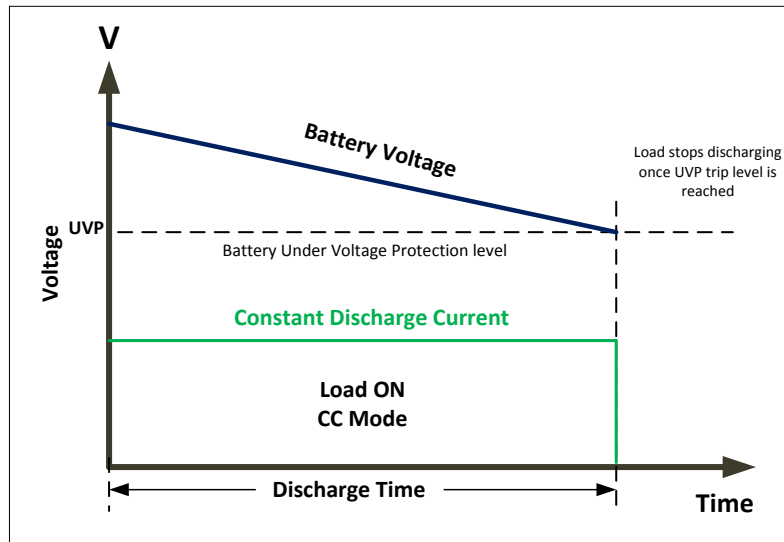

Figure 3-5: Battery TYPE1 Test Protocol Illustration

At the end of the test, the discharge time and total discharged energy is displayed.

### 3.4.2 BATTERY TYPE2 Test Description

Battery TYPE2 mode discharges a battery in constant current (CC) mode using set current level till the battery voltage drops below a preset under voltage protection (UVP) threshold. Once reached, load switches to constant voltage (CV) mode and holds the battery voltage if possible. Programmable parameter is the UVP value shown in figure below.

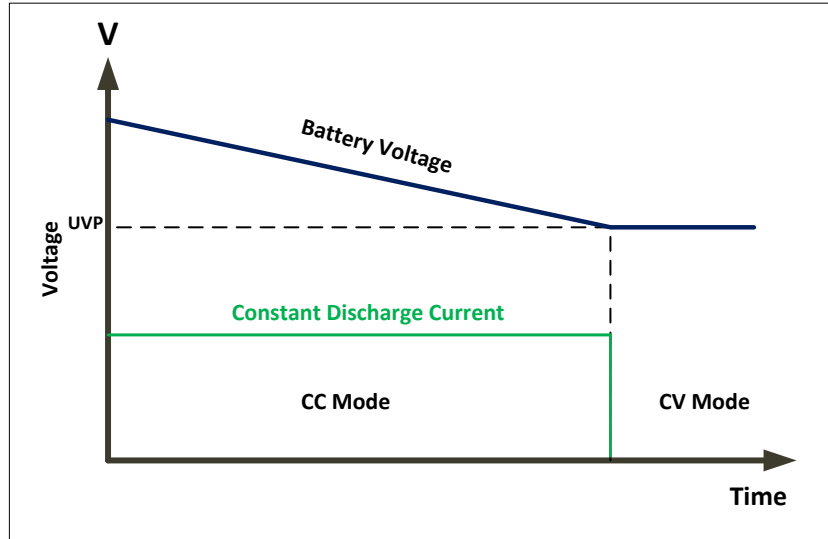

Figure 3-6: Battery TYPE2 Test Protocol Illustration

At the end of the test, the discharge time and total discharged energy is displayed.

### 3.4.3 BATTERY TYPE3 Test Description

Battery TYPE3 mode discharges battery in constant current (CC) mode using set current level for a period of time specified by the user. At end of test time, the load turns off and displays battery discharged voltage level. Programmable parameter is the discharge time in seconds as shown in figure below. The discharge time can be set from 1 sec to 99,999 secs. This corresponds to a maximum time setting of 27 hours, 46 minutes and 39 seconds.

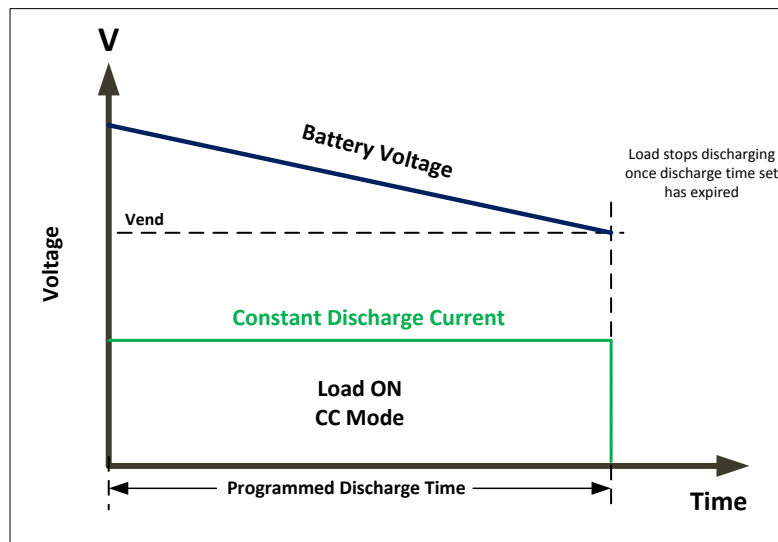

Figure 3-7: Battery TYPE3 Test Protocol Illustration

At the end of the test, the battery end voltage total discharged energy is displayed.

### 3.4.4 BATTERY TYPE4 Test Description

Battery TYPE4 mode discharges the battery using a pulsed current mode programmed sequence. This mode uses the dynamic CC mode of the DC load but adds three cycles, a cycle count for each cycle and repeat settings.

Available TYPE4 parameter settings and ranges are:

1. No of cycles: 1 to 2000
2. No of Steps: 1 to 3
3. Repeat count: 0 to 9999

**Note:** TYPE4 mode and these parameters can only set over the remote control interface. See section 8, “Remote Control Command Descriptions”, on page 177 for command syntax.

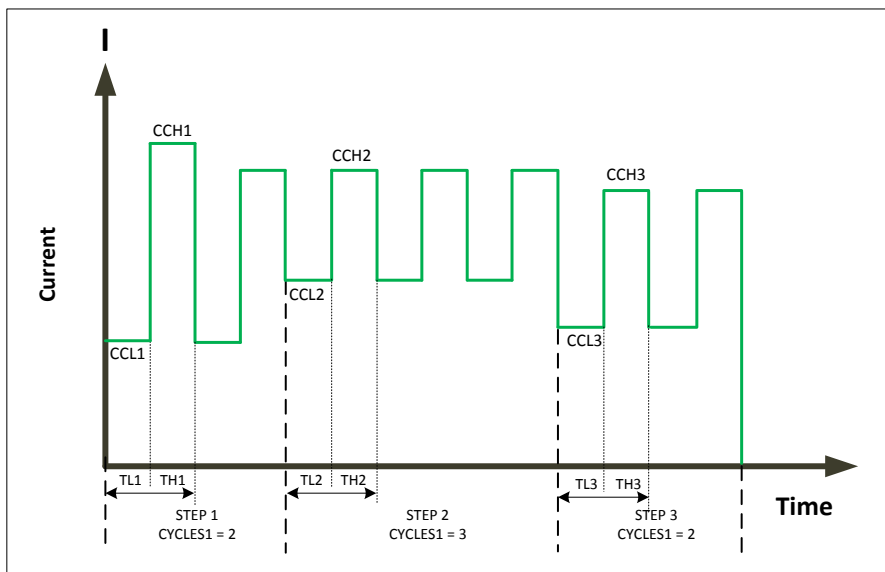

Figure 3-8: Battery TYPE4 Test Protocol Illustration

Once the repeat counter reaches zero, the load turns off and displays “OK” as well as the end voltage of the battery on the left LCD display in volts. End voltage and total energy discharged can be queried over the remote control interface.

### 3.4.5 BATTERY TYPE5 Test Description

Battery TYPE5 mode discharges the battery using a ramp current programmed sequence. This mode uses the settings for the dynamic current waveform of the dynamic CC mode, of the DC load but adds nine cycles, a cycle count for each cycle and repeat settings. Each current discharge level (CCx) has a corresponding transition time between current levels ( $\Delta T_x$ ) associated with it. In this mode, the current is slewed between levels at preset time intervals.

Available TYPE5 parameter settings and ranges are:

1. CC0 to CC9 Depends on load model
2.  $\Delta T1$  to  $\Delta T9$  0 to 6000 secs (10 minutes)
3. No of cycles: 1 to 2000
4. No of Steps: 1 to 9
5. Repeat count: 0 to 9999

Where  $\Delta CC = (CC_n - (CC_{n-1}))/\Delta T_n$ .

**Note:** TYPE5 mode and these parameters can only set over the remote control interface. See section 8, “Remote Control Command Descriptions”, on page 177 for command syntax.

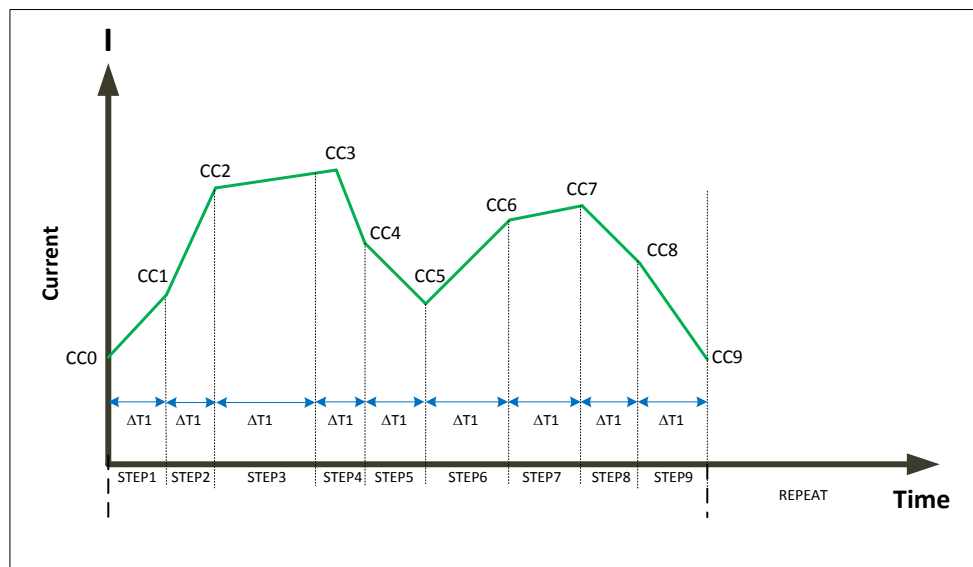

Figure 3-9: Battery TYPE5 Test Protocol Illustration

Once the repeat counter reaches zero, the load turns off and displays “OK” as well as the end voltage of the battery on the left LCD display in volts. End voltage and total energy discharged can be queried over the remote control interface.

### 3.5 Current Read-back

The load current levels and load status can be set from the front panel or over the remote control interface. During testing, load input voltage and load current can be read back but the current read back will typically display the average current level unless the dynamic current frequency setting is low enough. An analog current monitor output is provided to allow capturing of dynamic current on a digital storage scope or data recorder.

### 3.6 Analog Input Mode

An analog input is provided at the rear panel to allow analog programming of load current using a function or arbitrary waveform generator. This allows any current profile within the performance envelope of the DC load to be used for perform dynamic load testing beyond the built in dynamic CC mode.

**Note:** This mode is supported in Constant Current (CC) and Constant Power (CP) modes only.

### 3.7 Product Features

The following key characteristics apply to all 5VP Series models.

- Fully programmable electronic DC load with flexible configuration and dual range capabilities
- CC, CR, CV, CP, dynamic, and short operating mode
- Full remote control of all load settings and metering read back
- Dual high accuracy and high-resolution 5 digit voltage and current meters
- Built-in pulse generator includes wide Thigh/Tlow dynamic load range, independent Rise/Fall load current slew rate control, and High/Low load level
- Controllable load current slew rate of load level change
- Load ON/OFF button
- Short circuit test with current measure capability
- Automatic battery discharge modes
- Dedicated over current and over power protection test functions
- Automatic voltage sensing and external sense
- Full protection from over power, over temperature, over voltage, and reverse polarity
- Analog current programming input
- Current monitor output signal (non-isolated)
- Variable fan speed control for quieter operation
- Easy roll, lockable casters allow for deployment of load in multiple locations

### 3.8 Accessories Included

The following accessories are included with each 5VP Series DC Load. If one or more of these is missing upon incoming inspection of the product, please contact Adaptive Power Systems customer service.

Item	Quantity
Operation Manual in PDF Format	1
Banana Plug (Red)	1
Banana Plug (Black)	1
Analog Input BNC Cable (1 meter/39.4")	1
Certificate of Conformance	1

Table 3-3: Included Accessories

### 3.9 Interface Options

Following options can be ordered at time of original purchase or may be added at a later time.

Option	Model No.
RS-232 Interface Option	Opt RS-232
GPIB Interface Option	Opt GPIB
USB Interface Option, Includes LAN/USB Driver CD ROM	Opt USB
LAN Interface Option, Includes LAN/USB Driver CD ROM	Opt LAN

Table 3-4: Available Remote Control Interface Options

### 3.10 Load Cable Options

The user may assembly his own DC load cable as desired. Alternatively, Adaptive Power Systems offers pre-assembled high current capable load cables in different lengths.

APS Model	Description	Min. Order Qty.
OPT-C1KA1	Load Cable, 1000A rated, 1 meter	2
OPT-C1KA2	Load Cable, 1000A rated, 2 meter	2
OPT-C1KA3	Load Cable, 1000A rated, 3 meter	2
OPT-C1KA4	Load Cable, 1000A rated, 4 meter	2
OPT-C1KA5	Load Cable, 1000A rated, 5 meter	2

Table 3-5: Available Load Cable Options

## 4 Technical Specifications

Technical specifications shown here apply at an ambient temperature of 25° C ± 5°. Refer to V-I curve and Very Low Voltage V-I Curve charts by models for operating envelope.

### 4.1 Operating Ranges

#### 60V Models

MODEL	5VP05-100	5VP10-100	5VP15-100	5VP20-100	5VP25-100	5VP30-100
<b>OPERATING RANGES</b>						
Power Ranges	0-0.5kW / 0-5kW	0-1.0kW / 0-10kW	0-1.5kW / 0-15kW	0-2.0kW / 0-20kW	0-2.5kW / 0-25kW	0-3.0kW/0-30kW
Current Ranges	0-100A / 0-1000A	0-100A / 0-1000A	0-100A / 0-1000A	0-100A / 0-1000A	0-100A / 0-1000A	0-100A / 0-1000A
Voltage Range	0-60.0 V					
Minimum Voltage	0.1V @ 100A / 0.7V @ 1000A					

#### 600V Models

MODEL	5VP05-16	5VP10-32	5VP15-48	5VP20-64	5VP25-80
<b>OPERATING RANGES</b>					
Power Ranges	0-0.5kW / 0-5kW	0-1.0kW / 0-10kW	0-1.5kW / 0-15kW	0-2.0kW / 0-20kW	0-2.5kW / 0-25kW
Current Ranges	0-16.0A / 0-160A	0-32.0A / 0-320A	0-48.0A / 0-480A	0-64.0A / 0-640A	0-80.0A / 0-800A
Voltage Range	0 - 600 V				
Minimum Voltage	20V @ 160A	20V @ 320A	20V @ 480A	20V @ 640A	20V @ 800A

MODEL	5VP30-96	5VP40-128	5VP50-21	5VP60-24
<b>OPERATING RANGES</b>				
Power Ranges	0-3.0kW / 0-30kW	0-4.0kW / 0-40kW	0-5.0kW / 0-50kW	0-6.0kW / 0-60kW
Current Ranges	0-96.0A / 0-960A	0-128.0A / 0-1280A	0-21.0A / 0-210A	0-24.0A / 0-240A
Voltage Range	0 - 600.0 V			
Minimum Voltage	20V @ 960A	10V @ 1280A	20V @ 210A	20V @ 240A

1000V Models					
MODEL	5VP05-05	5VP10-10	5VP15-15	5VP20-20	5VP25-25
<b>OPERATING RANGES</b>					
Power Ranges	0-0.5kW / 0-5kW	0-1.0kW / 0-10kW	0-1.5kW / 0-15kW	0-2.0kW / 0-20kW	0-2.5kW / 0-25kW
Current Ranges	0 - 5.0 A / 0 - 50 A	0 - 10 A / 0 - 100 A	0 - 15 A / 0 - 150 A	0 - 20 A / 0 - 200 A	0 - 25 A / 0 - 250 A
Voltage Range	0 - 1000.0 V				
Minimum Voltage	20V @ 50A	20V @ 100A	20V @ 150A	20V @ 200A	20V @ 250A

MODEL	5VP30-30	5VP35-35	5VP40-40	5VP50-50	5VP60-60
<b>OPERATING RANGES</b>					
Power Ranges	0-3.0kW / 0-30kW	0-3.5kW / 0-35kW	0-4.0kW / 0-40kW	0-5.0kW / 0-50kW	0-6.0kW / 0-60kW
Current Ranges	0 - 30 A / 0 - 300 A	0 - 35 A / 0 - 350 A	0 - 40 A / 0 - 400 A	0 - 52.5 A / 0 - 500 A	0 - 60 A / 0 - 600 A
Voltage Range	0 - 1000.0 V				
Minimum Voltage	20V @ 300A	20V @ 350A	20V @ 400A	20V @ 500A	20V @ 600A

## 4.2 Operating Modes

60V Models							
MODEL	5VP05-100	5VP10-100	5VP15-100	5VP20-100	5VP25-100	5VP30-100	
<b>OPERATING MODES</b>							
CC Mode	Range	0-100A / 0-1000A	0-100A / 0-1000A	0-100A / 0-1000A	0-100A / 0-1000A	0-100A / 0-1000A	0-100A / 0-1000A
	Resolution	1.667mA/16.67mA	1.667mA/16.67mA	1.667mA/16.67mA	1.667mA/16.67mA	1.667mA/16.67mA	1.667mA/16.67mA
	Accuracy	± 0.1% OF (SETTING + RANGE)					
CR Mode	Range	0.001 - 0.06Ω / 0.06 - 3600Ω					
	Resolution	0.001mΩ / 277μΩ					
	Accuracy	± 0.2% OF (SETTING + RANGE)					
CV Mode	Range	0-60.0 V					
	Resolution	1.0 mV					
	Accuracy	± 0.05% OF (SETTING + RANGE)					
CP Mode	Range	0-0.5kW / 0-5kW	0-1.0kW / 0-10kW	0-1.5kW / 0-15kW	0-2.0kW / 0-20kW	0-2.5kW / 0-25kW	0-3.0kW / 0-30kW
	Resolution	8.34mW / 83.4mW	16.7mW / 167mW	25mW / 250mW	33.4mW / 334mW	41.7mW / 417mW	50mW / 500mW
	Accuracy	± 0.5% OF (SETTING + RANGE)					

**600V Models**

MODEL		5VP05-16	5VP10-32	5VP15-48	5VP20-64	5VP25-80
<b>OPERATING MODES</b>						
CC Mode	Range	0-16.0A / 0-160A	0-32.0A / 0-320A	0-48.0A / 0-480A	0-64.0A / 0-640A	0-80.0A / 0-800A
	Resolution	0.267mA / 2.67mA	0.534mA / 5.34mA	0.8mA / 8.0mA	1.067mA / 10.67mA	1.334mA / 13.34mA
	Accuracy	± 0.1% OF (SETTING + RANGE)				
CR Mode	Range	0.0378Ω-3.75Ω 3.75Ω-15000Ω	0.0192Ω-1.875Ω 1.875Ω-12500Ω	0.0126Ω-1.25Ω 1.25Ω-15000Ω	0.0096Ω-0.9375Ω 0.9375Ω-11250Ω	0.0078Ω-0.75Ω 0.75Ω-11250Ω
	Resolution	63μΩ / 4.4μΩ	0.032mΩ / 0.0088mΩ	0.021mΩ / 0.0133mΩ	0.016mΩ / 0.0177mΩ	0.013mΩ / 0.0222mΩ
	Accuracy	± 0.2% OF (SETTING + RANGE)				
CV Mode	Range	0-600.0 V				
	Resolution	10 mV				
	Accuracy	± 0.05% OF (SETTING + RANGE)				
CP Mode	Range	0-0.5kW / 0-5kW	0-1.0kW / 0-10kW	0-1.5kW / 0-15kW	0-2.0kW / 0-20kW	0-2.5kW / 0-25kW
	Resolution	8.34mW / 83.4mW	16.7mW / 167mW	25mW / 250mW	33.4mW / 334mW	41.7mW / 417mW
	Accuracy	± 0.5% OF (SETTING + RANGE)				

MODEL		5VP30-96	5VP40-128	5VP50-21	5VP60-24
<b>OPERATING MODES</b>					
CC Mode	Range	0-96.0A / 0-960A	0-96.0A / 0-960A	0-21.0A / 0-210A	0-24.0A / 0-240A
	Resolution	1.6mA / 16.0mA	1.6mA / 16.0mA	0.35mA / 3.5mA	0.4mA / 4.0mA
	Accuracy	± 0.1% OF (SETTING + RANGE)			
CR Mode	Range	0.0066Ω-0.625Ω 0.625Ω-12500Ω	0.008Ω ~ 0.468Ω 0.468Ω ~ 1404Ω	0.0286Ω-2.857Ω 2.857Ω-8571Ω	0.0834Ω-2.5Ω 2.5Ω-7500Ω
	Resolution	0.011mΩ / 0.0266mΩ	0.0009mΩ / 0.0356mΩ	47.7uΩ / 5.83uS	41.7uΩ / 6.66uS
	Accuracy	± 0.2% OF (SETTING + RANGE)			
CV Mode	Range	0-600.0 V			
	Resolution	10 mV			
	Accuracy	± 0.05% OF (SETTING + RANGE)			
CP Mode	Range	0-3.0kW / 0-30kW	0-4.0kW / 0-40kW	0-5.25kW / 0-50kW	0-6.0kW / 0-60kW
	Resolution	50mW / 500mW	64mW / 640mW	87.5mW / 875mW	0.1W / 1.0 W
	Accuracy	± 0.5% OF (SETTING + RANGE)			

1000V Models						
MODEL		5VP05-05	5VP10-10	5VP15-15	5VP20-20	5VP25-25
<b>OPERATING MODES</b>						
CC Mode	Range	0 - 5.0 A / 0 - 50 A	0 - 10 A / 0 - 100 A	0 - 15 A / 0 - 150 A	0 - 20 A / 0 - 200 A	0 - 25 A / 0 - 250 A
	Resolution	0.08mA / 0.8mA	0.16mA / 1.6mA	0.25mA / 2.5mA	0.32mA / 3.2mA	0.4mA / 4mA
	Accuracy	± 0.1% OF (SETTING + RANGE)				
CR Mode	Range	0.4008Ω-20Ω / 20Ω-24000Ω	0.2004Ω-10Ω/ 10Ω-12000Ω	0.1344Ω-6.666Ω /6.666Ω-8000Ω	0.1008Ω-5Ω / 5Ω-6000Ω	0.0804Ω-4Ω/ 4Ω-4800Ω
	Resolution	0.334mΩ / 0.833μΩ	0.167mΩ / 1.666μΩ	0.112mΩ / 2.5μΩ	0.084mΩ / 3.33μΩ	0.067mΩ / 4.166μΩ
	Accuracy	± 0.2% OF (SETTING + RANGE)				
CV Mode	Range	20.0 - 1000.0 V				
	Resolution	16mV				
	Accuracy	± 0.05% OF (SETTING + RANGE)				
CP Mode	Range	0-0.5kW / 0-5kW	0-1.0kW / 0-10kW	0-1.5kW / 0-15kW	0-2.0kW / 0-20kW	0-2.5kW / 0-25kW
	Resolution	8mW / 80mW	16mW / 160mW	25mW / 250mW	32mW / 320mW	40mW / 400mW
	Accuracy	± 0.5% OF (SETTING + RANGE)				

MODEL		5VP30-30	5VP35-35	5VP40-40	5VP50-50	5VP60-60
<b>OPERATING MODES</b>						
CC Mode	Range	0 - 30 A / 0 - 300 A	0 - 35 A / 0 - 350 A	0 - 40 A / 0 - 400 A	0 - 52.5 A / 0 - 500 A	0 - 60 A / 0 - 600 A
	Resolution	0.5mA / 5mA	0.56mA / 5.6mA	0.64mA / 6.4mA	0.875mA / 87.5mA	1.0mA / 10mA
	Accuracy	± 0.1% OF (SETTING + RANGE)				
CR Mode	Range	0.0672Ω-3.333Ω /3.333Ω-4000Ω	0.0576Ω-2.857Ω/2.857Ω-3428.4Ω	0.0504Ω-2.5Ω/2.5Ω-3000Ω	0.0384Ω-1.905Ω/ 1.905Ω-11430Ω	0.0333Ω-1.666Ω/1.666Ω-10000Ω
	Resolution	0.056mΩ / 5.0005μΩ	0.048mΩ / 5.84μΩ	0.042mΩ / 6.66μΩ	32uΩ / 8.75uS	27.8uΩ / 10uS
	Accuracy	± 0.2% OF (SETTING + RANGE)				
CV Mode	Range	20.0 - 1000.0 V				
	Resolution	16mV				
	Accuracy	± 0.05% OF (SETTING + RANGE)				
CP Mode	Range	0-3.0kW / 0-30kW	0-3.5kW / 0-35kW	0-4.0kW / 0-40kW	0-5.0kW / 0-50kW	0-6.0kW / 0-60kW
	Resolution	50mW / 500mW	56mW / 560mW	64mW / 640mW	87.5mW / 875mW	0.1 W / 1.0 W
	Accuracy	± 0.5% OF (SETTING + RANGE)				

### 4.3 Protection Modes

#### 60V Models

MODEL	5VP05-100	5VP10-100	5VP15-100	5VP20-100	5VP25-100	5VP30-100
<b>PROTECTION MODES</b>						
Over Power (OP)	5250 W	10500 W	15750 W	21000 W	26250 W	31500 W
Over Current (OC)	1010 A	1050 A	1050 A	1050 A	1050 A	1050 A
Over Voltage (OV)	63.0 V					
Over Temperature (OT)	+85° C / +185° F					

#### 600V Models

MODEL	5VP05-16	5VP10-32	5VP15-48	5VP20-64	5VP25-80
<b>PROTECTION MODES</b>					
Over Power (OP)	5250 W	10500 W	15750 W	21000 W	26250 W
Over Current (OC)	168 A	336 A	504 A	672 A	840 A
Over Voltage (OV)	630.0 V				
Over Temperature (OT)	+85° C / +185° F				

MODEL	5VP30-96	5VP40-128	5VP50-21	5VP60-24
<b>PROTECTION MODES</b>				
Over Power (OP)	31500 W	42000 W	52500 W	63000 W
Over Current (OC)	1008 A	1344 A	220.5 A	252 A
Over Voltage (OV)	630.0 V			
Over Temperature (OT)	+85° C / +185° F			

#### 1000V Models

MODEL	5VP05-05	5VP10-10	5VP15-15	5VP20-20	5VP25-25
<b>PROTECTION MODES</b>					
Over Power (OP)	5250 W	10500 W	15750 W	21000 W	26250 W
Over Current (OC)	52.0 A	104.0 A	156.0 A	208.0 A	260.0 A
Over Voltage (OV)	1040.0 V				
Over Temperature (OT)	+85° C / +185° F				

MODEL	5VP30-30	5VP35-35	5VP40-40	5VP50-50	5VP60-60
<b>PROTECTION MODES</b>					
Over Power (OP)	31500 W	36750 W	42000 W	52500 W	63000 W
Over Current (OC)	312 A	364 A	416 A	520 A	624 A
Over Voltage (OV)	1040.0 V				
Over Temperature (OT)	+85° C / +185° F				

## 4.4 Dynamic Operation Mode

### 60V Models

MODEL	5VP05-100	5VP10-100	5VP15-100	5VP20-100	5VP25-100	5VP30-100
<b>DYNAMIC OPERATION</b>						
T high & T low	0.150-9.999/.../9999ms		0.050-9.999 / 99.99 / 999.9 / 9999ms (20 kHz)			
Resolution	0.001 / 0.01 / 0.1 / 1ms					
Accuracy	1 $\mu$ s / 10 $\mu$ s / 100 $\mu$ s / 1ms + 50ppm					
Slew Rate	24mA-1.5A/ $\mu$ s		66.4mA-4.15A/ $\mu$ s			
	240mA-15A/ $\mu$ s		664mA-41.5A/ $\mu$ s			
Min. Rise Time	66.7 $\mu$ s Typical		24 $\mu$ s Typical			

### 600V Models

MODEL	5VP05-16	5VP10-32	5VP15-48	5VP20-64	5VP25-80
<b>DYNAMIC OPERATION</b>					
T high & T low	0.050-9.999 / 99.99 / 999.9 / 9999ms (20 kHz)				
Resolution	0.001 / 0.01 / 0.1 / 1ms				
Accuracy	1 $\mu$ s / 10 $\mu$ s / 100 $\mu$ s / 1ms + 50ppm				
Slew Rate	12.8mA-800mA/ $\mu$ s	25.6mA-1.6A/ $\mu$ s	38.4mA-2.4A/ $\mu$ s	51.2mA-3.2A/ $\mu$ s	64mA-4A/ $\mu$ s
	128mA-8A/ $\mu$ s	256mA-16A/ $\mu$ s	384mA-24A/ $\mu$ s	512mA-32A/ $\mu$ s	640mA-40A/ $\mu$ s
Min. Rise Time	20 $\mu$ s Typical				

MODEL	5VP30-96	5VP40-128	5VP50-21	5VP60-24
<b>DYNAMIC OPERATION</b>				
T high & T low	0.050-9.999 / 99.99 / 999.9 / 9999ms (20 kHz)			
Resolution	0.001 / 0.01 / 0.1 / 1ms			
Accuracy	1 $\mu$ s / 10 $\mu$ s / 100 $\mu$ s / 1ms + 50ppm			
Slew Rate	76.8mA-4.8A/ $\mu$ s	0.1024A-6.4A/us	16.8mA-1.05A/uS	19.2mA-1.2A/uS
	768mA-48A/ $\mu$ s	1.024A-64A/us	168mA-10.5A/uS	192mA-12A/uS
Min. Rise Time	20 $\mu$ s Typical			

**1000V Models**

MODEL	5VP05-05	5VP10-10	5VP15-15	5VP20-20	5VP25-25
<b>DYNAMIC OPERATION</b>					
T high & T low	0.050-9.999 / 99.99 / 999.9 / 9999ms (20 kHz)				
Resolution	0.001 / 0.01 / 0.1 / 1ms				
Accuracy	1µs / 10µs / 100µs / 1ms + 50ppm				
Slew Rate	0.004A-0.25A/µs	0.008A-0.5A/µs	0.012A-0.75A/µs	0.016A-1A/µs	0.02A-1.25A/µs
	0.04A-2.5A/µs	0.08A-5A/µs	0.12A-7.5A/µs	0.16A-10A/µs	0.2A-12.5A/µs
Min. Rise Time	20µs Typical				

MODEL	5VP30-30	5VP35-35	5VP40-40	5VP50-50	5VP60-60
-------	----------	----------	----------	----------	----------

<b>DYNAMIC OPERATION</b>					
T high & T low	0.050-9.999 / 99.99 / 999.9 / 9999ms (20 kHz)				
Resolution	0.001 / 0.01 / 0.1 / 1ms				
Accuracy	1µs / 10µs / 100µs / 1ms + 50ppm				
Slew Rate	0.024A-1.5A/µs	0.028A-1.75A/µs	0.032A-2A/µs	42mA-2.625A/uS	48mA-3A/uS
	0.24A-15A/µs	0.28A-17.5A/µs	0.32A-20A/µs	420mA-26.25A/uS	480mA-30A/uS
Min. Rise Time	20µs Typical				

## 4.5 Metering

**60V Models**

MODEL	5VP05-100	5VP10-100	5VP15-100	5VP20-100	5VP25-100	5VP30-100	
<b>METERING</b>							
Voltage	Range	0 - 6.0 V / 0 - 60.0 V					
	Resolution	0.1 mV / 1.0 mV					
	Accuracy	± 0.025% OF (READING + RANGE)					
Current	Range	0-100A / 0-1000 A					
	Resolution	1.667mA / 16.67mA					
	Accuracy	± 0.1% OF (READING + RANGE)					
Power	Range	0-0.5kW / 0-5kW	0-1.0kW / 0-10kW	0-1.5kW / 0-15kW	0-2.0kW / 0-20kW	0-2.5kW / 0-25kW	0-3.0kW / 0-30kW
	Resolution	0.01 W / 0.1W	0.01 W / 0.1W	0.01 W / 0.1W	0.01 W / 0.1W	0.01 W / 0.1W	0.01 W / 0.1W
	Accuracy	± 0.125% OF (READING + RANGE)					

**600V Models**

MODEL		5VP05-16	5VP10-32	5VP15-48	5VP20-64	5VP25-80
<b>METERING</b>						
Voltage	Range	0 - 60.0 V / 0 - 600 V				
	Resolution	0.1 mV / 1.0 mV				
	Accuracy	± 0.025% OF (READING + RANGE)				
Current	Range	0-16.0A / 0-160A	0-32.0A / 0-320A	0-48.0A / 0-480A	0-64.0A / 0-640A	0-80.0A / 0-800A
	Resolution	0.267mA / 2.67mA	0.534mA / 5.34mA	0.8mA / 8.0mA	1.067mA / 10.67mA	1.334mA / 13.34mA
	Accuracy	± 0.1% OF (READING + RANGE)				
Power	Range	0-0.5kW / 0-5kW	0-1.0kW / 0-10kW	0-1.5kW / 0-15kW	0-2.0kW / 0-20kW	0-2.5kW / 0-25kW
	Resolution	0.01 W / 0.1W	0.01 W / 0.1W	0.01 W / 0.1W	0.01 W / 0.1W	0.01 W / 0.1W
	Accuracy	± 0.125% OF (READING + RANGE)				

MODEL		5VP30-96	5VP40-128	5VP50-21	5VP60-24
<b>METERING</b>					
Voltage	Range	0 - 60.0 V / 0 - 600 V			
	Resolution	0.1 mV / 1.0 mV			
	Accuracy	± 0.025% OF (READING + RANGE)			
Current	Range	0-96.0A / 0-960A	0-128 A / 0-1280 A	0-21.0A / 0-210A	0-24.0A / 0-240A
	Resolution	1.6mA / 16.0mA	2.134mA / 21.34mA	0.35mA / 3.5mA	0.4mA / 4mA
	Accuracy	± 0.1% OF (READING + RANGE)			
Power	Range	0-3.0kW / 0-30kW	0-4.0kW / 0-40kW	0-5.0kW / 0-50kW	0-6.0kW / 0-60kW
	Resolution	0.01 W / 0.1W	0.01 W / 0.1W	0.01 W / 0.1W	0.01 W / 0.1W
	Accuracy	± 0.125% OF (READING + RANGE)			

**1000V Models**

MODEL		5VP05-05	5VP10-10	5VP15-15	5VP20-20	5VP25-25
<b>METERING</b>						
Voltage	Range	0 - 100.0 V / 100 - 1000 V				
	Resolution	1.6 mV / 16 mV				
	Accuracy	± 0.025% OF (READING + RANGE)				
Current	Range	0 - 5.0 A / 0 - 50 A	0 - 10 A / 0 - 100 A	0 - 15 A / 0 - 150 A	0 - 20 A / 0 - 200 A	0 - 25 A / 0 - 250 A
	Resolution	0.08mA / 0.8mA	0.16mA / 1.6mA	0.25mA / 2.5mA	0.32mA / 3.2mA	0.4mA / 4mA
	Accuracy	± 0.1% OF (READING + RANGE)				
Power	Range	0-0.5kW / 0-5kW	0-1.0kW / 0-10kW	0-1.5kW / 0-15kW	0-2.0kW / 0-20kW	0-2.5kW / 0-25kW
	Resolution	0.01 W / 0.1W	0.01 W / 0.1W	0.01 W / 0.1W	0.01 W / 0.1W	0.01 W / 0.1W
	Accuracy	± 0.125% OF (READING + RANGE)				

MODEL		5VP30-30	5VP35-35	5VP40-40	5VP50-50	5VP60-60
<b>METERING</b>						
Voltage	Range	0 - 100.0 V / 100 - 1000 V				
	Resolution	1.6 mV / 16 mV				
	Accuracy	± 0.025% OF (READING + RANGE)				
Current	Range	0 - 30 A / 0 - 300 A	0 - 35 A / 0 - 350 A	0 - 40 A / 0 - 400 A	0 - 52.5 A / 0 - 500 A	0 - 60 A / 0 - 600 A
	Resolution	0.5mA / 5mA	0.56mA / 5.6mA	0.64mA / 6.4mA	0.8mA / 8mA	1.0mA / 10mA
	Accuracy	± 0.1% OF (READING + RANGE)				
Power	Range	0-3.0kW / 0-30kW	0-3.5kW / 0-35kW	0-4.0kW / 0-40kW	0-5.0kW / 0-50kW	0-6.0kW / 0-60kW
	Resolution	0.01 W / 0.1W	0.01 W / 0.1W	0.01 W / 0.1W	0.01 W / 0.1W	0.01 W / 0.1W
	Accuracy	± 0.125% OF (READING + RANGE)				

## 4.6 Miscellaneous

### 60V Models

MODEL	5VP05-100	5VP10-100	5VP15-100	5VP20-100	5VP25-100	5VP30-100
SHORT CIRCUIT						
Max. Short Current	1000 A					
ANALOG I/O						
Analog Monitor Out	0 - 10 V out F.S. / 1K $\Omega$ Zout, Non-isolated					
Analog Input (CC mode)	0 - 10V in for F.S. current @ 10V					

### 600V Models

MODEL	5VP05-16	5VP10-32	5VP15-48	5VP20-64	5VP25-80
SHORT CIRCUIT					
Max. Short Current	160 A	320 A	480 A	640 A	800 A
ANALOG I/O					
Analog Monitor Out	0 - 10 V out F.S. / 1K $\Omega$ Zout, Non-isolated				
Analog Input (CC mode)	0 - 10V in for F.S. current @ 10V				

MODEL	5VP30-96	5VP40-128	5VP50-21	5VP60-24
SHORT CIRCUIT				
Max. Short Current	960 A	1280 A	210 A	240 A
ANALOG I/O				
Analog Monitor Out	0 - 10 V out F.S. / 1K $\Omega$ Zout, Non-isolated			
Analog Input (CC mode)	0 - 10V in for F.S. current @ 10V			

### 1000V Models

MODEL	5VP05-05	5VP10-10	5VP15-15	5VP20-20	5VP25-25
SHORT CIRCUIT					
Max. Short Current	50 A	100 A	150 A	200 A	250 A
ANALOG I/O					
Analog Monitor Out	0 - 10 V out F.S. / 1K $\Omega$ Zout, Non-isolated				
Analog Input (CC mode)	0 - 10V in for F.S. current @ 10V				

MODEL	5VP30-30	5VP35-35	5VP40-40	5VP50-50	5VP60-60
SHORT CIRCUIT					
Max. Short Current	300 A	350 A	400 A	500 A	600 A
ANALOG I/O					
Analog Monitor Out	0 - 10 V out F.S. / 1K $\Omega$ Zout, Non-isolated				
Analog Input (CC mode)	0 - 10V in for F.S. current @ 10V				

## 4.7 AC Input & Cooling

### 60V Models

MODEL	5VP05-100	5VP10-100	5VP15-100	5VP20-100	5VP25-100	5VP30-100
<b>AC INPUT AND COOLING SPECIFICATIONS</b>						
AC Input	100-240Vac ± 10%, 50/60 Hz					208-240Vac ± 10%
Power Consumption	600 W	1000 W	1450 W	1900 W	2350 W	2800 W
Cooling	Variable Speed Fan Cooled / Front Air Intake, Rear Exhaust					

### 600V Models

MODEL	5VP05-16	5VP10-32	5VP15-48	5VP20-64	5VP25-80
<b>AC INPUT AND COOLING SPECIFICATIONS</b>					
AC Input	100-240Vac ± 10%, 50/60 Hz				
Power Consumption	600 W	1000 W	1450 W	1900 W	2350 W
Cooling	Variable Speed Fan Cooled / Front Air Intake, Rear Exhaust				

MODEL	5VP30-96	5VP40-128	5VP50-21	5VP60-24
<b>AC INPUT AND COOLING SPECIFICATIONS</b>				
AC Input	208-240Vac ± 10%, 50/60 Hz			
Power Consumption	2800 W	3700 W	5450 W	5500 W
Cooling	Variable Speed Fan Cooled / Front Air Intake, Rear Exhaust			

### 1000V Models

MODEL	5VP05-05	5VP10-10	5VP15-15	5VP20-20	5VP25-25
<b>AC INPUT AND COOLING SPECIFICATIONS</b>					
AC Input	100-240Vac ± 10%, 50/60 Hz				
Power Consumption	600 W	1000 W	1450 W	1900 W	2350 W
Cooling	Variable Speed Fan Cooled / Front Air Intake, Rear Exhaust				

MODEL	5VP30-30	5VP35-35	5VP40-40	5VP50-50	5VP60-60
<b>AC INPUT AND COOLING SPECIFICATIONS</b>					
AC Input	208-240Vac ± 10%, 50/60 Hz				
Power Consumption	2800 W	3250 W	3700 W	5450 W	6200 W
Cooling	Variable Speed Fan Cooled / Front Air Intake, Rear Exhaust				

## 4.8 Dimensions & Weight

### 60V Models

MODEL	5VP05-100	5VP10-100	5VP15-100	5VP20-100	5VP25-100	5VP30-100
<b>OVERALL DIMENSIONS AND WEIGHT</b>						
Dimensions (H x W x D)	577x647x766mm 22.7"x25.5"x30.2"		736x 647x766mm 29"x25.5"x30.2"	889x 647x 766mm 35"x25.5"x30.2"	1048x647x766mm 41.3"x25.5"x30.2"	1201x647x766mm 47.3"x25.5"x30.2"
Weight (Net)	100kg / 220.5 lbs	130kg / 286.6 lbs	170kg / 374.8 lbs	220kg / 485.0 lbs	280kg / 617.3 lbs	340kg / 749.6 lbs

### 600V Models

MODEL	5VP05-16	5VP10-32	5VP15-48	5VP20-64	5VP25-80
<b>OVERALL DIMENSIONS AND WEIGHT</b>					
Dimensions (H x W x D)	577x647x766mm 22.7"x25.5"x30.2"		736x 647x766mm 29"x25.5"x30.2"	889x 647x 766mm 35"x25.5"x30.2"	1048x647x766mm 41.3"x25.5"x30.2"
Weight (Net)	100kg / 220.5 lbs	130kg / 286.6 lbs	170kg / 374.8 lbs	220kg / 485.0 lbs	280kg / 617.3 lbs

MODEL	5VP30-96	5VP40-128	5VP50-21	5VP60-24
<b>OVERALL DIMENSIONS AND WEIGHT</b>				
Dimensions (H x W x D)	1201x647x766mm 47.3"x25.5"x30.2"	1513x647x766mm 59.6"x25.5"x30.2"	1360x853x766 mm 53.6"x33.6"x30.2"	1513x853x66mm 59.6"x33.6"x30.2"
Weight (Net)	340kg / 749.6 lbs	430 Kg / 948 lbs.	510kg/1124.4 lbs	630kg/1388.9 lbs

### 1000V Models

MODEL	5VP05-05	5VP10-10	5VP15-15	5VP20-20	5VP25-25
<b>DIMENSIONS AND WEIGHT</b>					
Dimensions (H x W x D)	577 x 647 x 766 mm 29" x 25.5" x 30.2"		736x647x766mm 29"x25.5"x30.2"	889x647x766mm 35"x25.5"x30.2"	1048x647x766mm 41.3"x25.5"x30.2"
Weight (Net)	100kg / 220.5 lbs	130kg / 286.6 lbs	170kg / 374.8 lbs	220kg / 485.0 lbs	280kg / 617.3 lbs

MODEL	5VP30-30	5VP35-35	5VP40-40	5VP50-50	5VP60-60
<b>OVERALL DIMENSIONS AND WEIGHT</b>					
Dimensions (H x W x D)	1201x647x766mm 47.3"x25.5"x30.2"	1360x647x766mm 53.6"x25.5"x30.2"	1513x647x76 6mm 59.6"x25.5"x30.2"	1360x853x766mm 53.6"x33.6"x30.2"	1513x853x766 mm 59.6"x33.6"x30.2"
Weight (Net)	340kg / 749.6 lbs	390kg / 859.8 lbs	430kg / 948.0 lbs	510kg / 1124.4 lbs	630kg / 1388.9 lbs

### 4.9 Detailed Chassis Dimensions

The 5VP Series comes in varies chassis heights to accommodate a range of power levels. The illustrations below are for a 5VP05-100 model. The chassis designs are similar however between varies 5VP model cabinet sizes.

The dimension table below references the letters A through J shown in the drawings on subsequent pages.

MODEL	A	B	C	D	E	F	G	H	I	J
DIMENSIONS (mm/inch)										
5KW Models	389 mm 15.3"	576 mm 22.69"	468 mm 18.43"	108 mm 4.25"	367 mm 14.45"	77.5 mm 3.05"	765.5 mm 30.15"	647 mm 25.47"	580 mm 22.83"	648 mm 25.5"
10KW Models		732 mm 28.83"	624 mm 24.57"							
15KW Models		888 mm 34.97"	780 mm 30.72"							
20KW Models		1044mm 41.11"	936 mm 36.86"							
25KW Models		1200 mm 47.25"	1092 mm 43.0"							
30KW Models		1356 mm 53.39"	1248 mm 49.14"							
40KW Models	595 mm 23.4"	1513 mm 59.54"	1404 mm 55.2"					853 mm 33.58"		
50KW Models										
60KW Models										

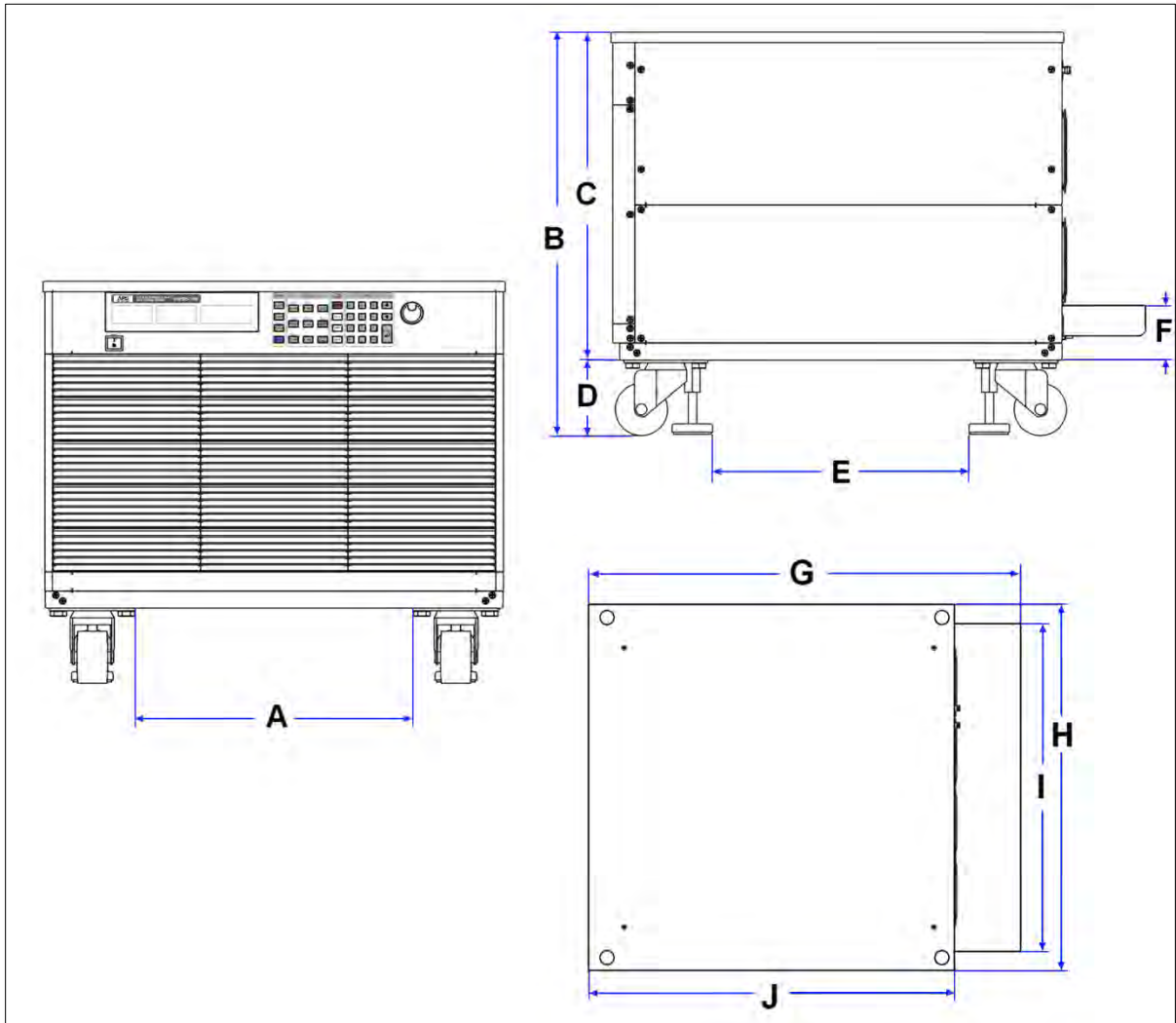

Figure 4-1: 5VP Series Cabinet Dimensions- Small

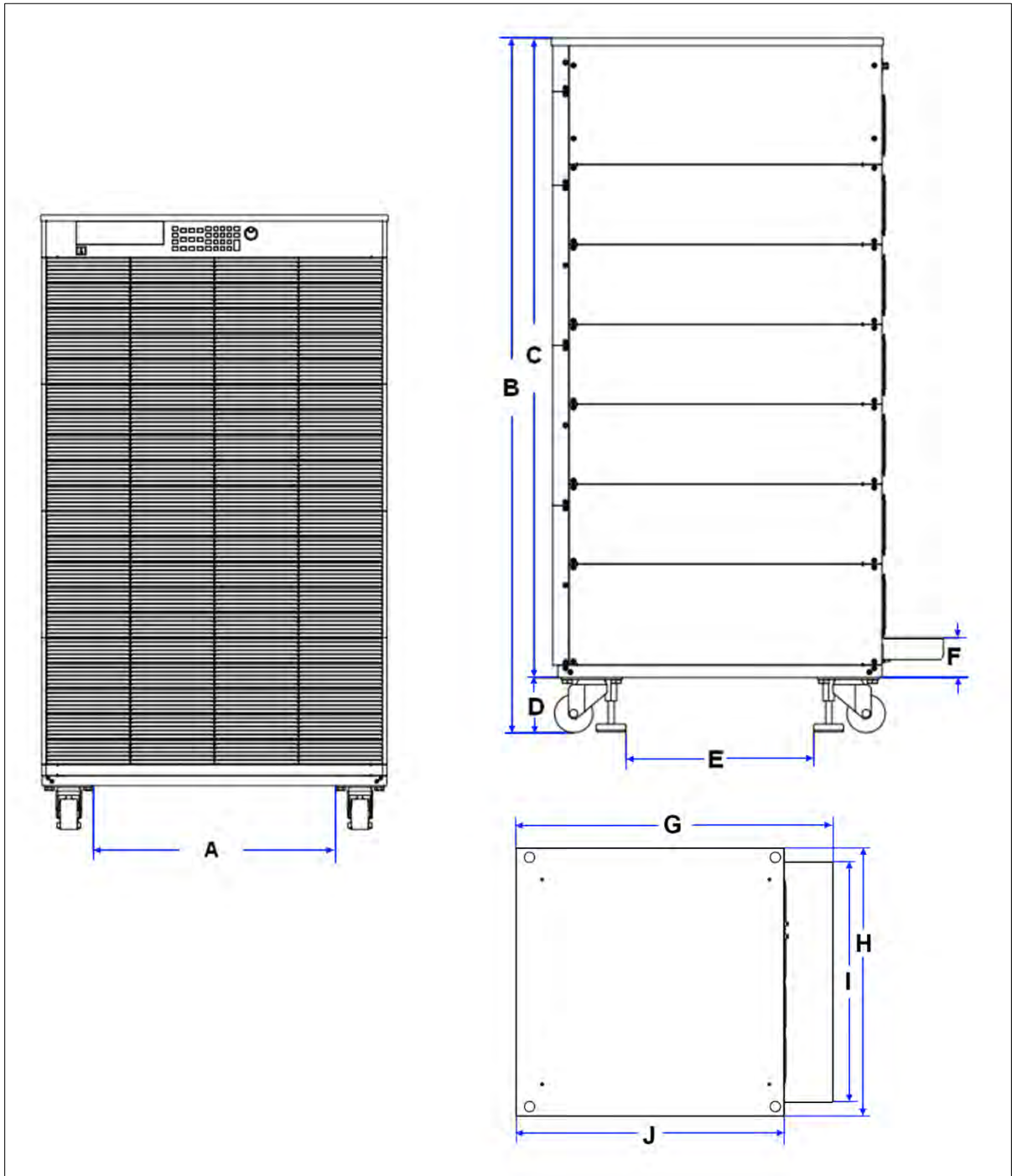

Figure 4-2: 5VP Series Cabinet Dimensions- Large

## 4.10 Environmental

MODEL	ALL MODELS
<b>ENVIRONMENTAL</b>	
Operating Temperature	0 - 40° C / 32 - 104° F
Relative Humidity	80% max. non-condensing
Environmental	Indoor Use Only, Pollution Degree 2
Altitude	2000 meter / 6500 feet max. Operating
EMC & Safety	CE Mark

## 4.11 Voltage versus Current Operating Envelope Charts

Following charts show constant power operating envelopes for each mode. For operation at voltages below 1.0 Vdc, refer to the Low Voltage Operating charts. Operation below the red line shown in these charts is not specified.

Charts are shown by model on following pages.

4.11.1 Model 5VP05-100 V-I Curves

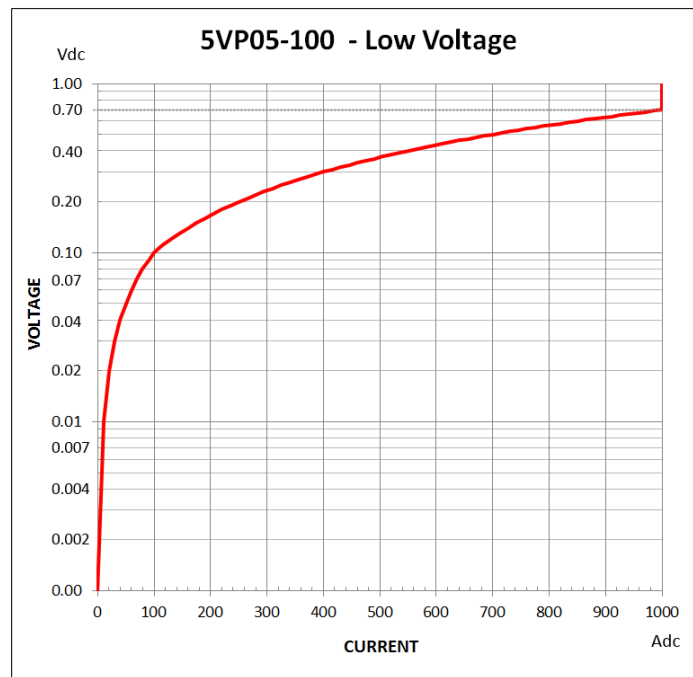
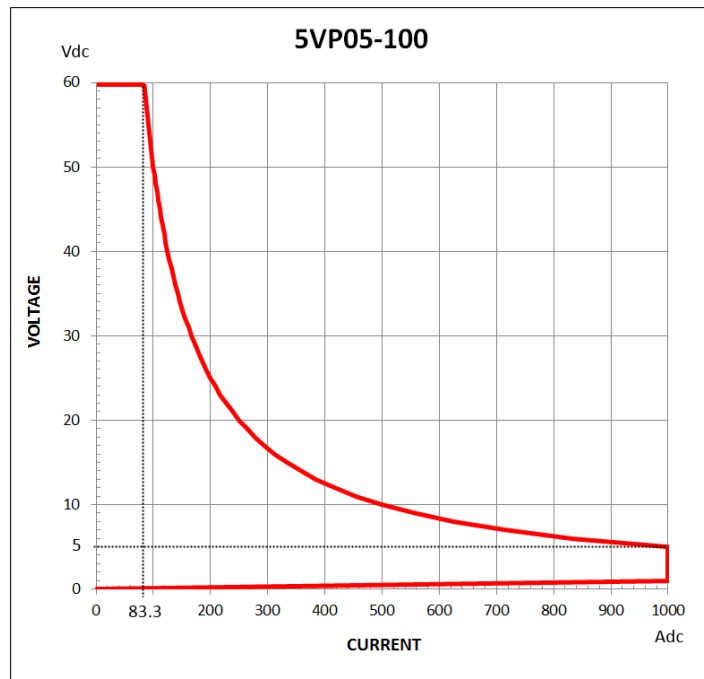

4.11.2 Model 5VP10-100 V-I Curves

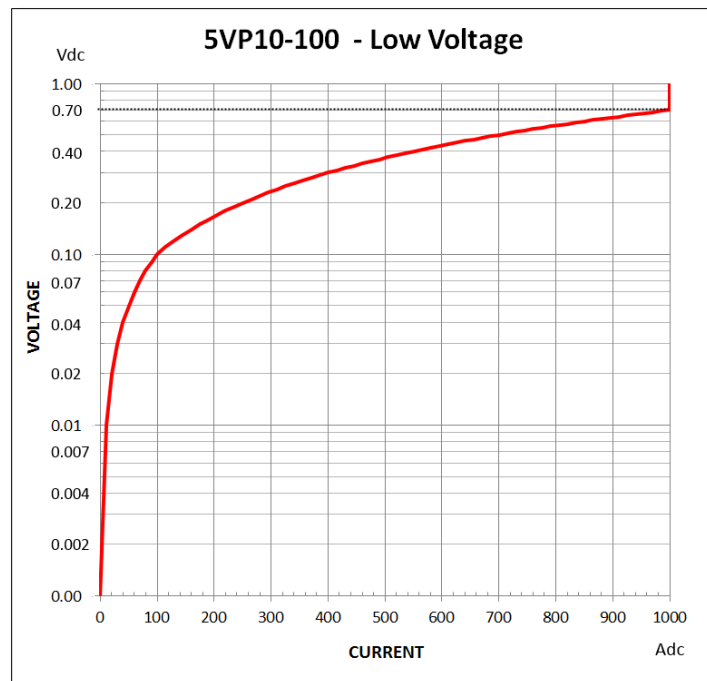
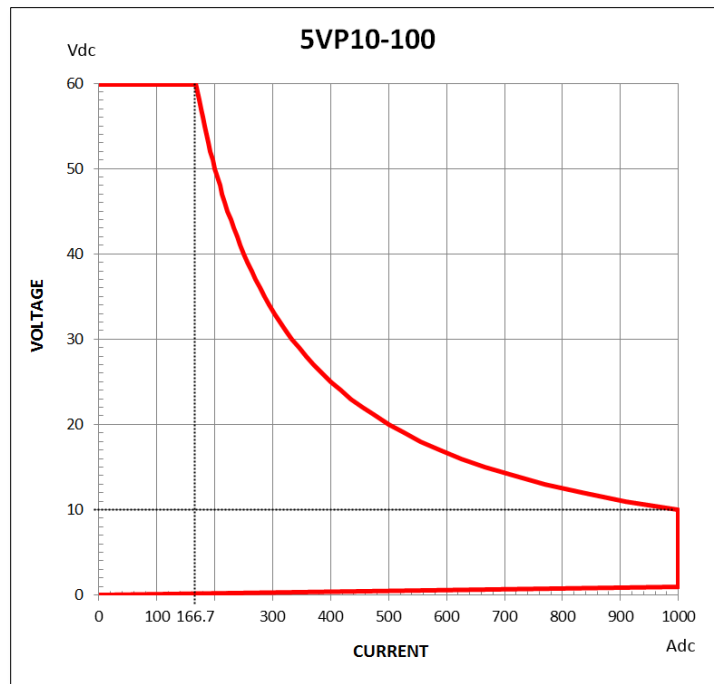

4.11.3 Model 5VP15-100 V-I Curves

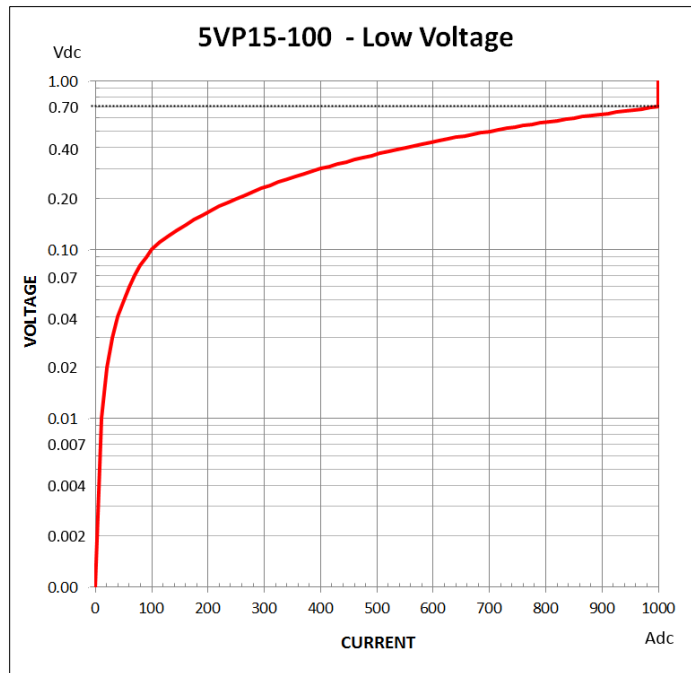
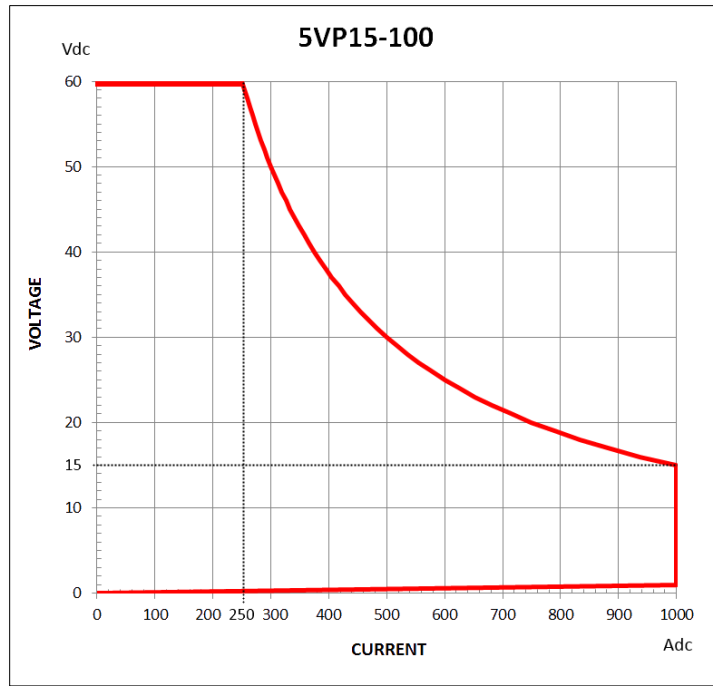

4.11.4 Model 5VP20-100 V-I Curves

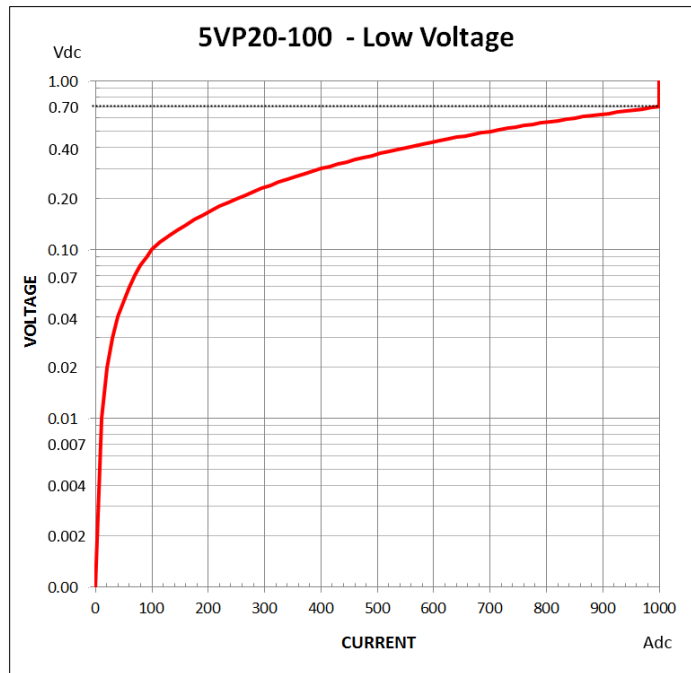
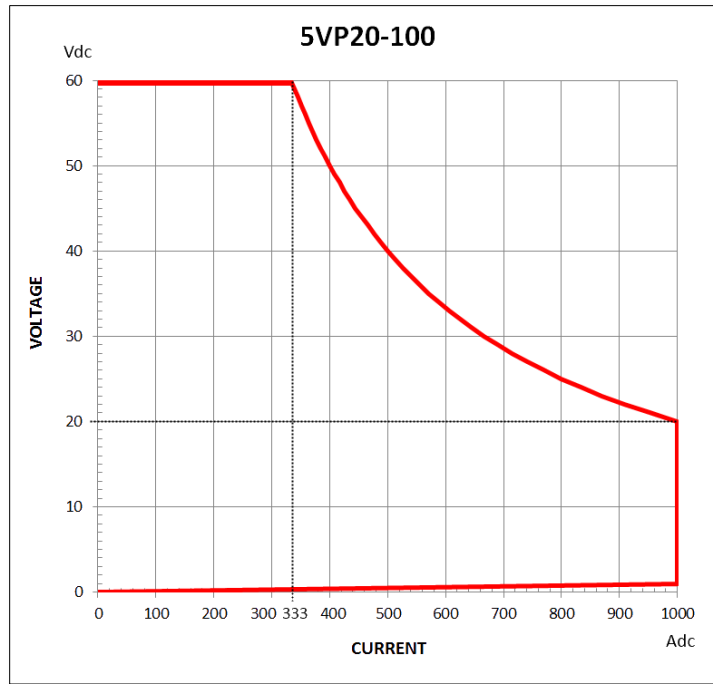

4.11.5 Model 5VP25-100 V-I Curves

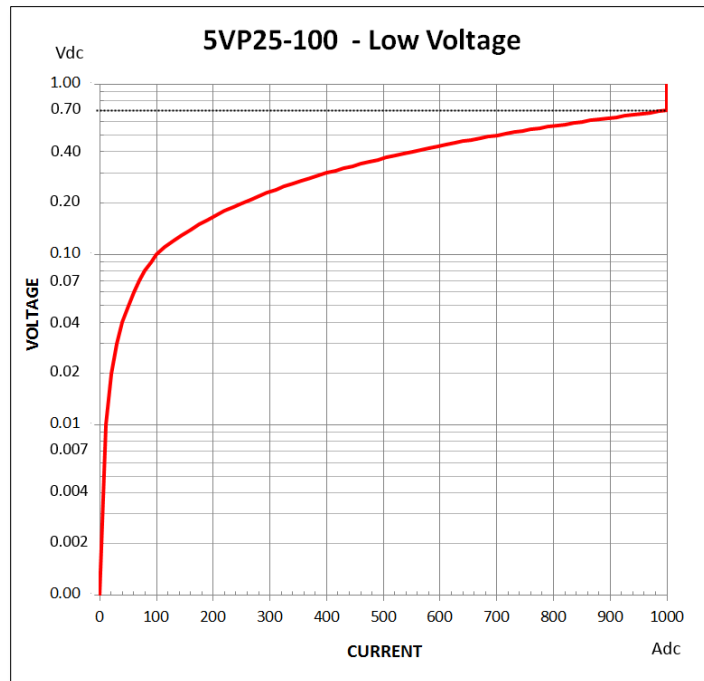
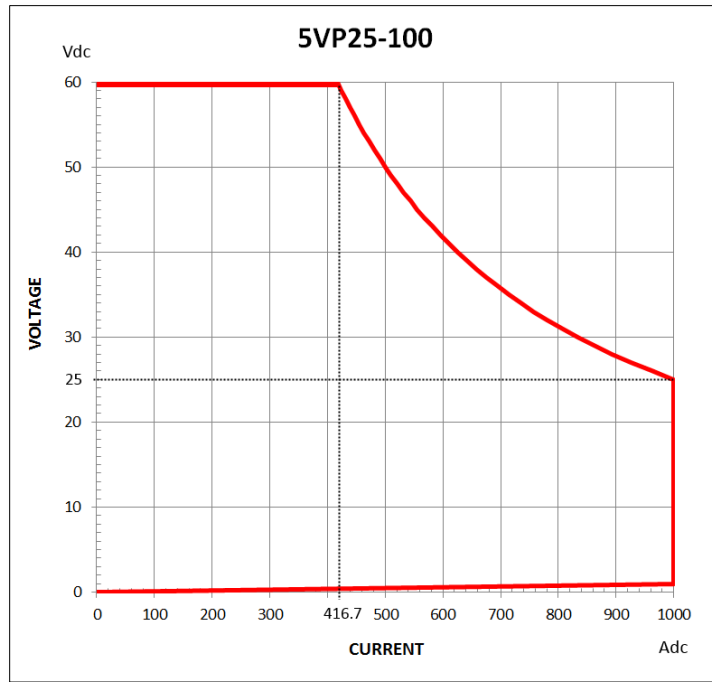

4.11.6 Model 5VP30-100 V-I Curves

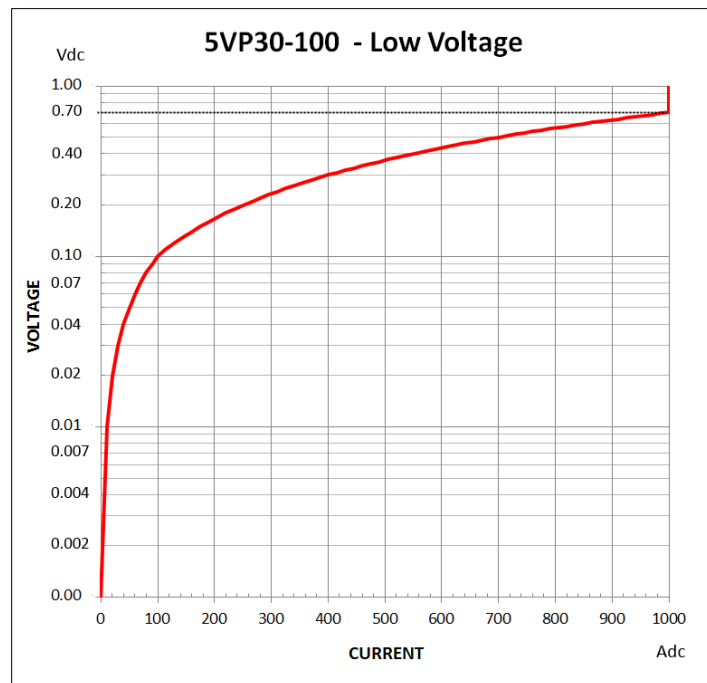
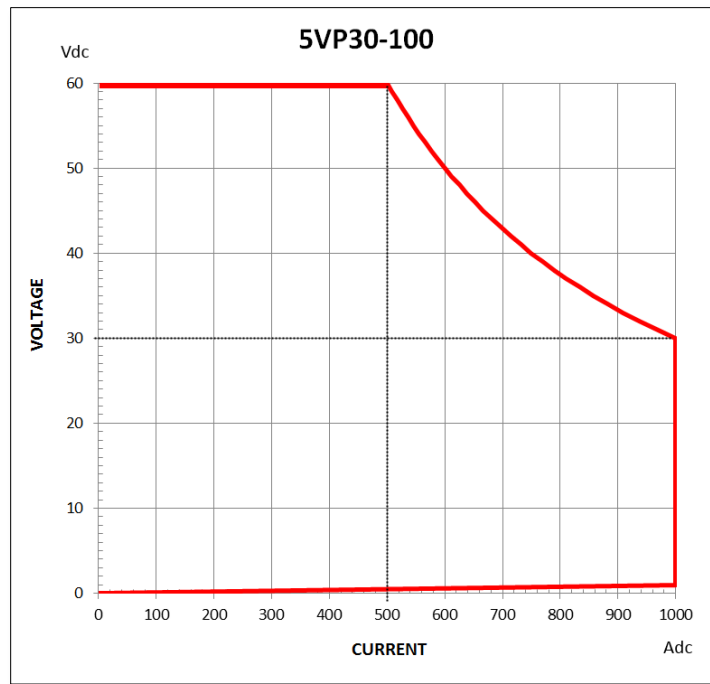

4.11.7 Model 5VP05-16 V-I Curves

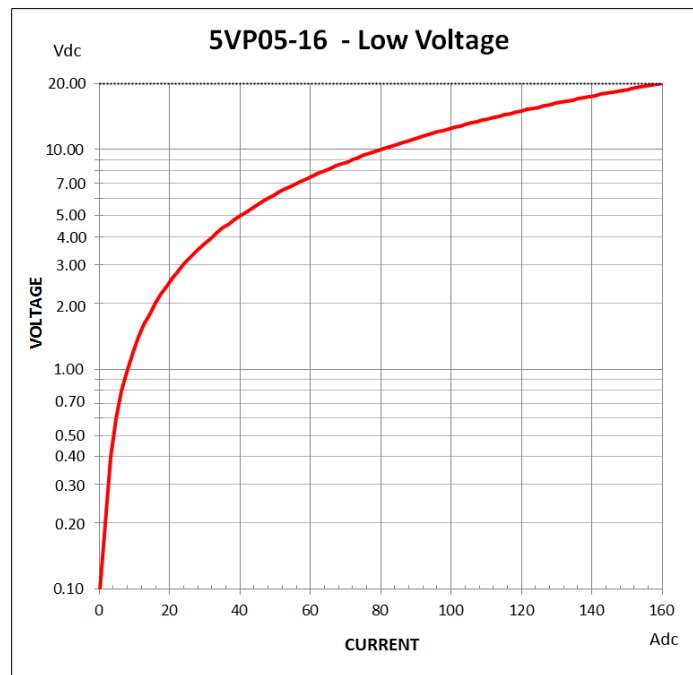
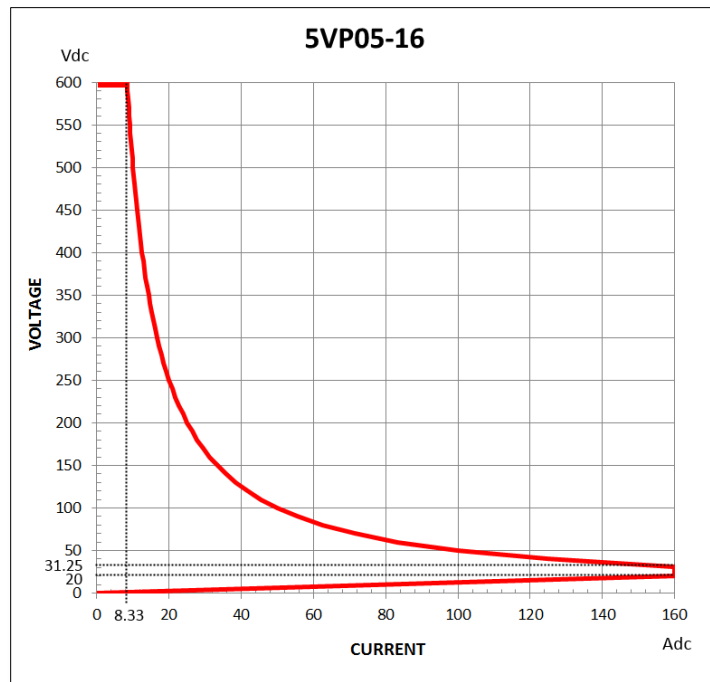

4.11.8 Model 5VP10-32 V-I Curves

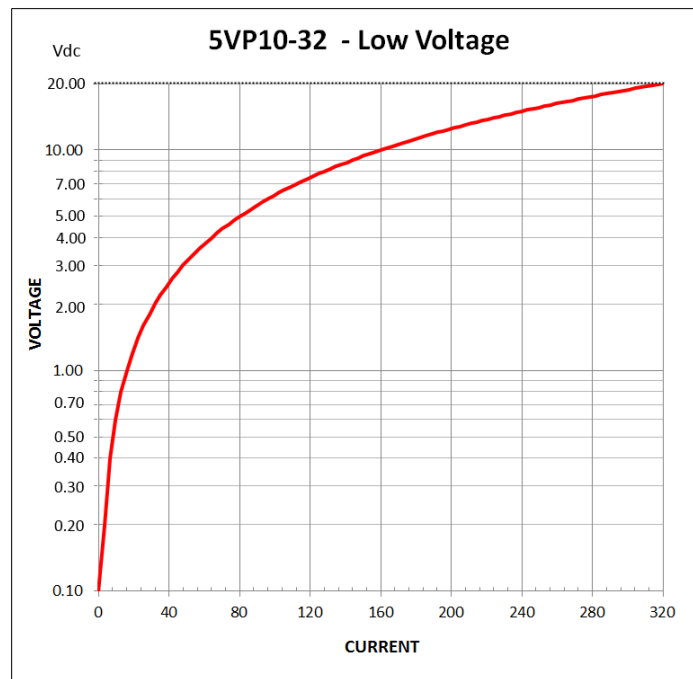
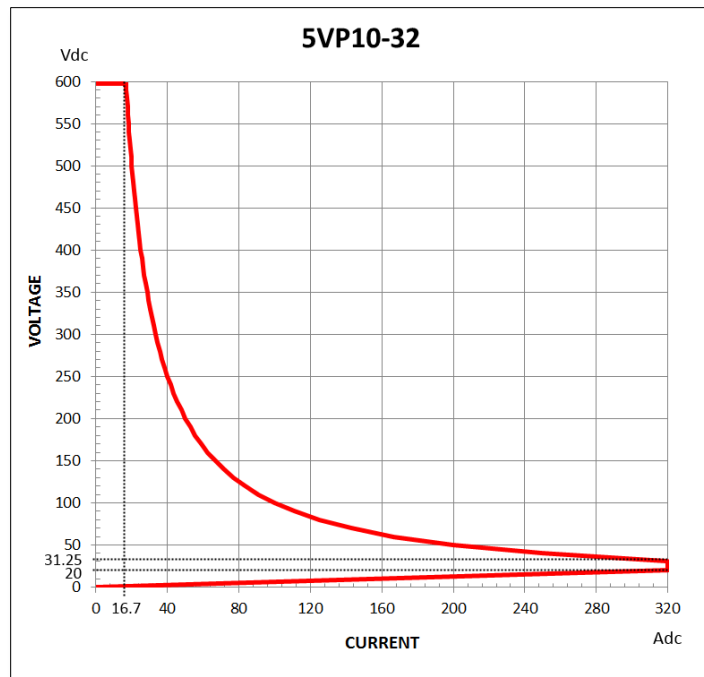

4.11.9 Model 5VP15-48 V-I Curves

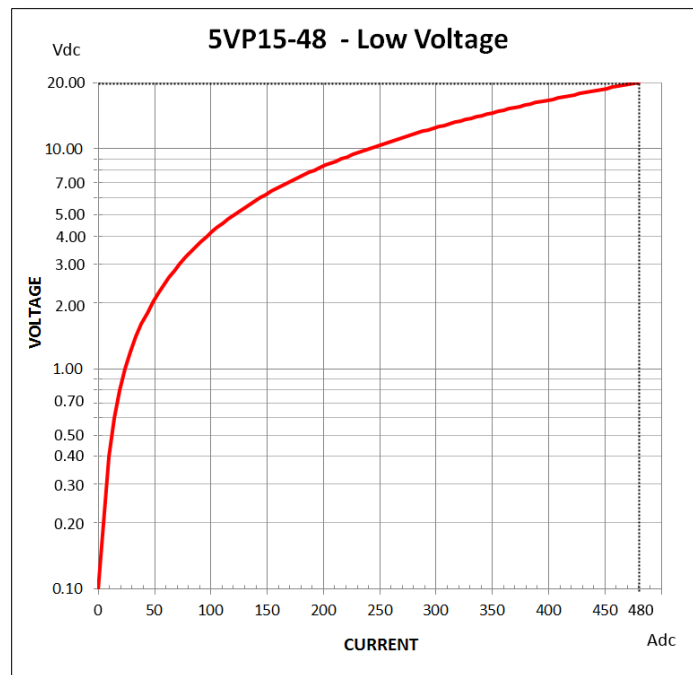
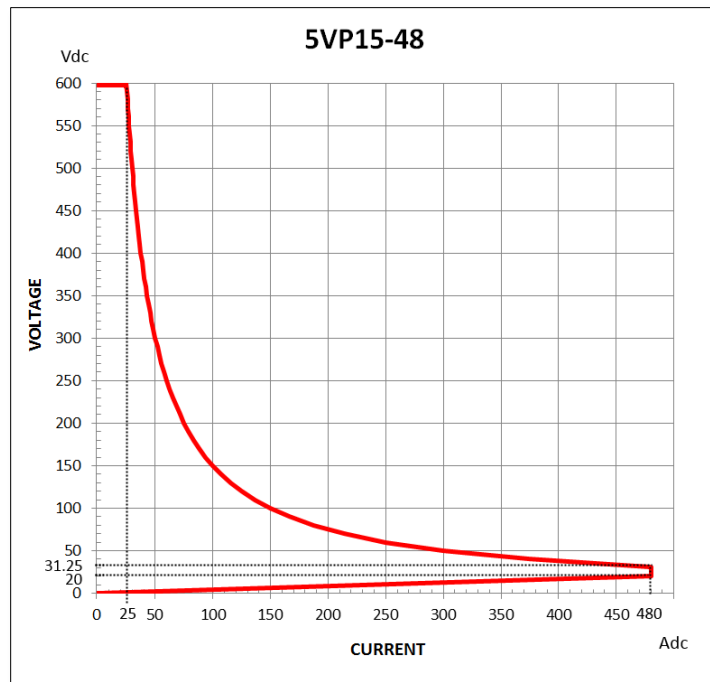

4.11.10 Model 5VP20-64 V-I Curves

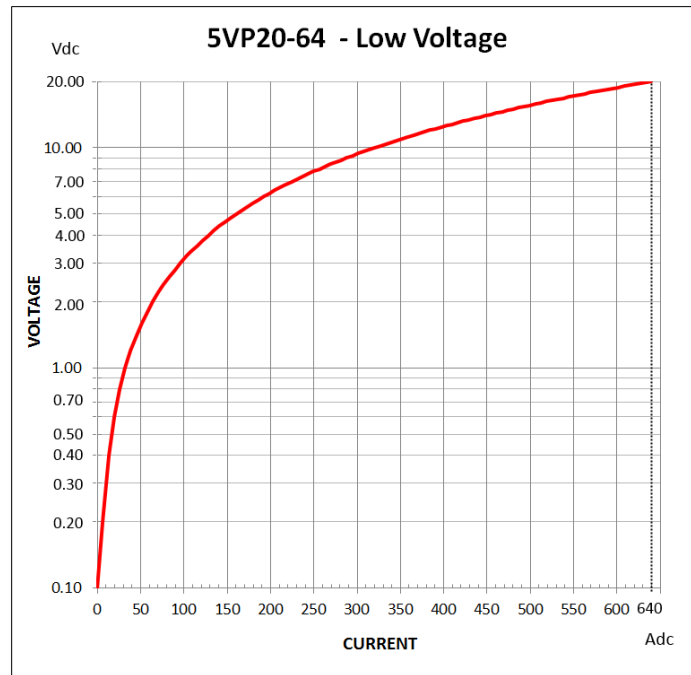
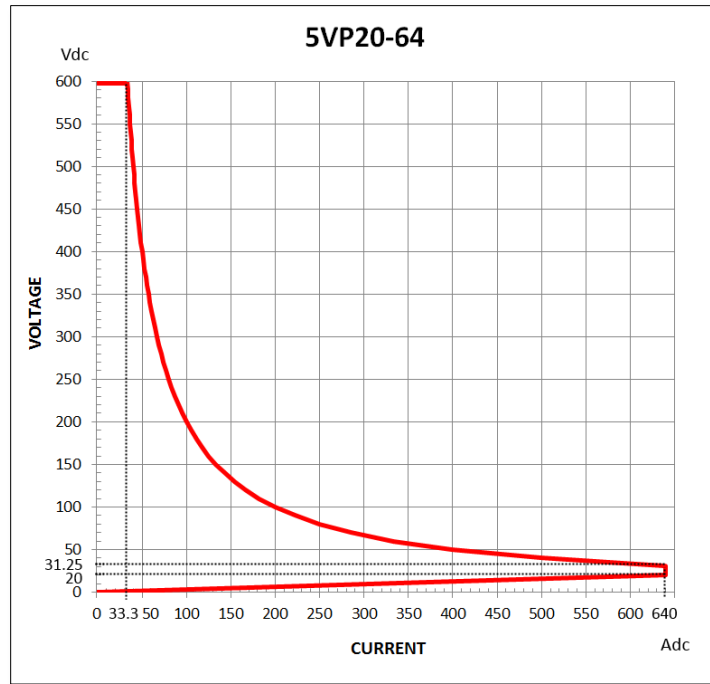

4.11.11 Model 5VP25-80 V-I Curves

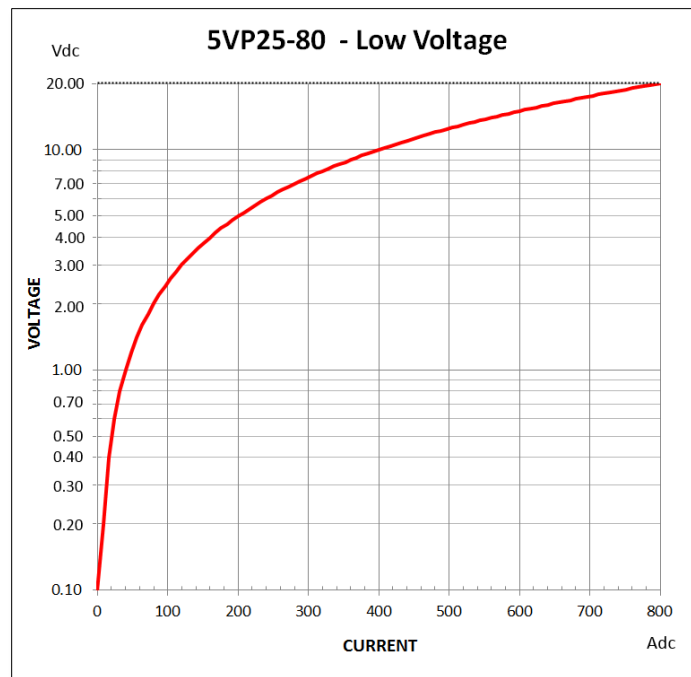
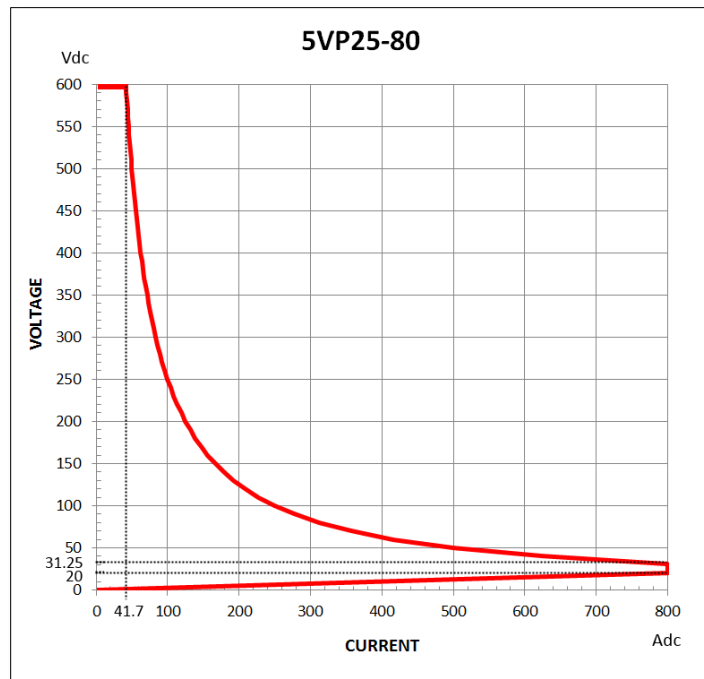

4.11.12 Model 5VP30-96 V-I Curves

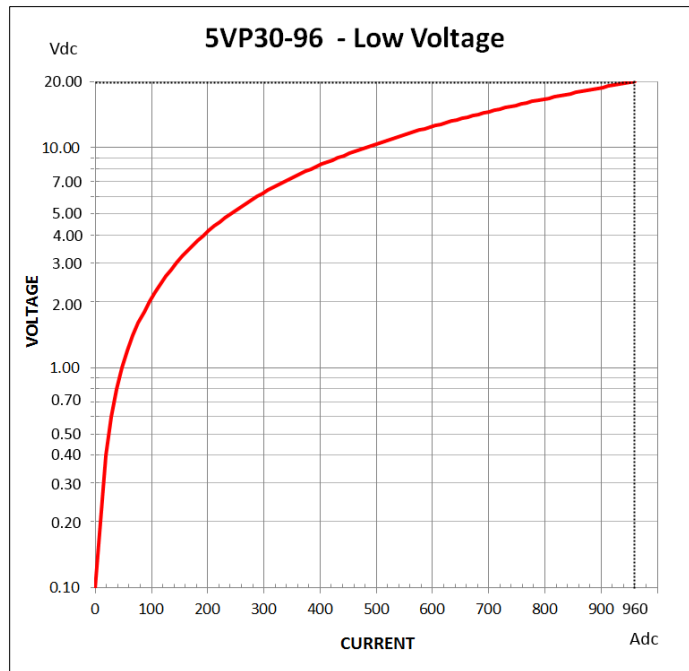
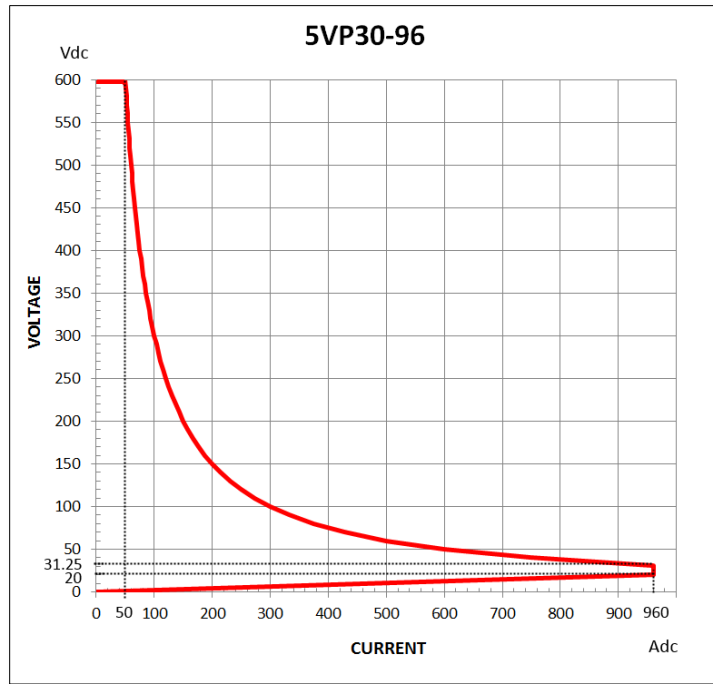

4.11.13 Model 5VP40-128 V-I Curves

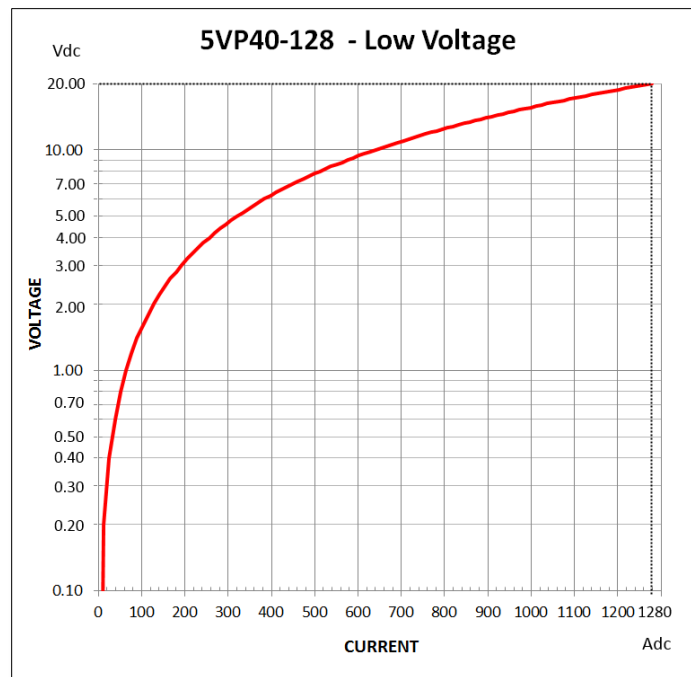
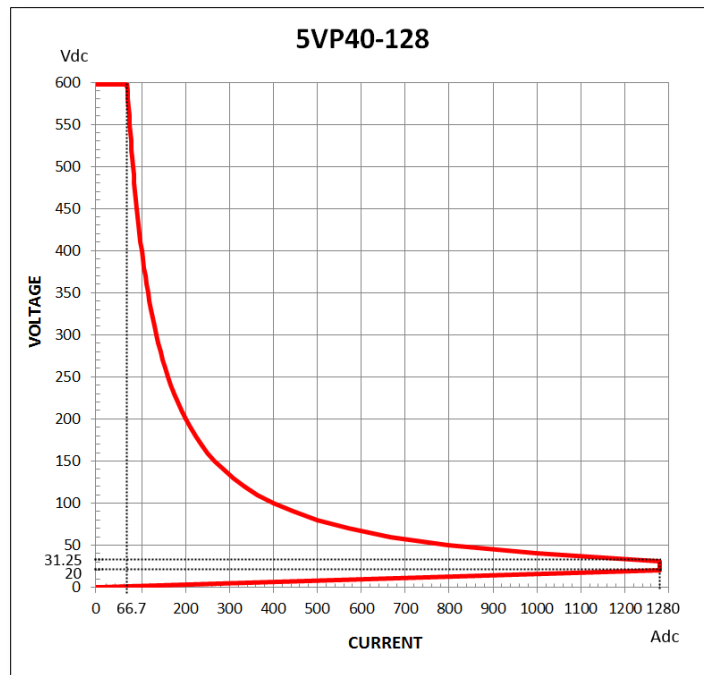

4.11.14 Model 5VP50-21 V-I Curves

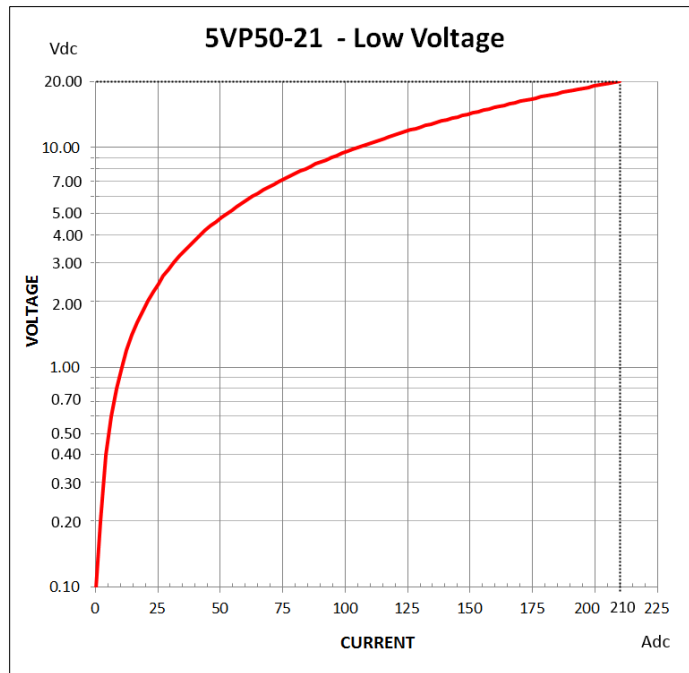
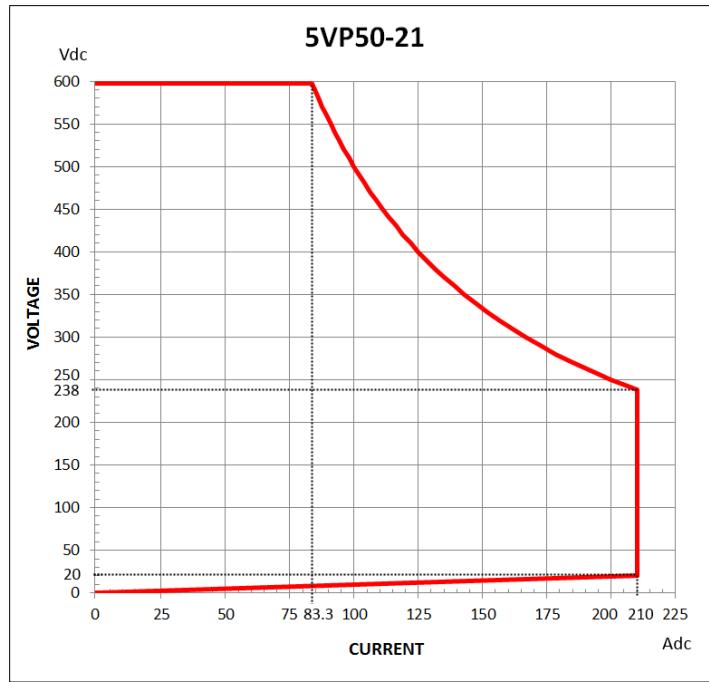

4.11.15 Model 5VP60-24 V-I Curves

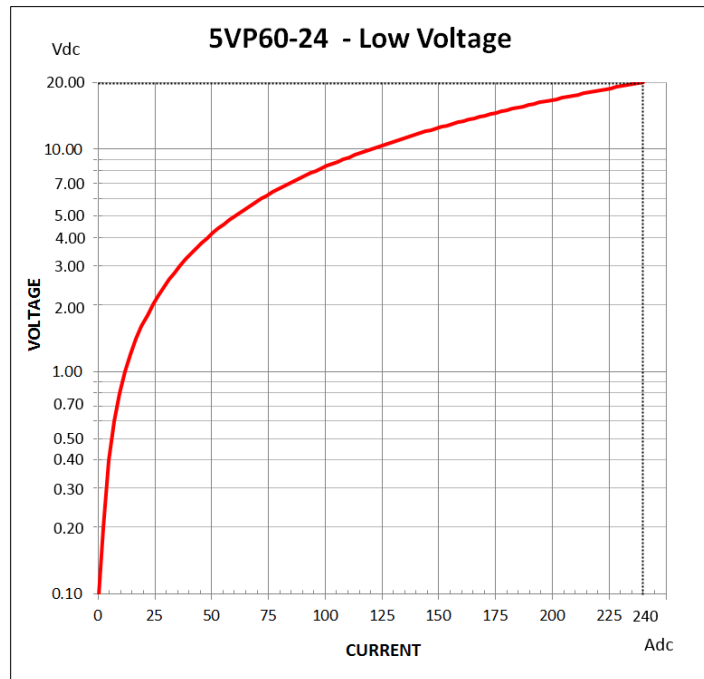
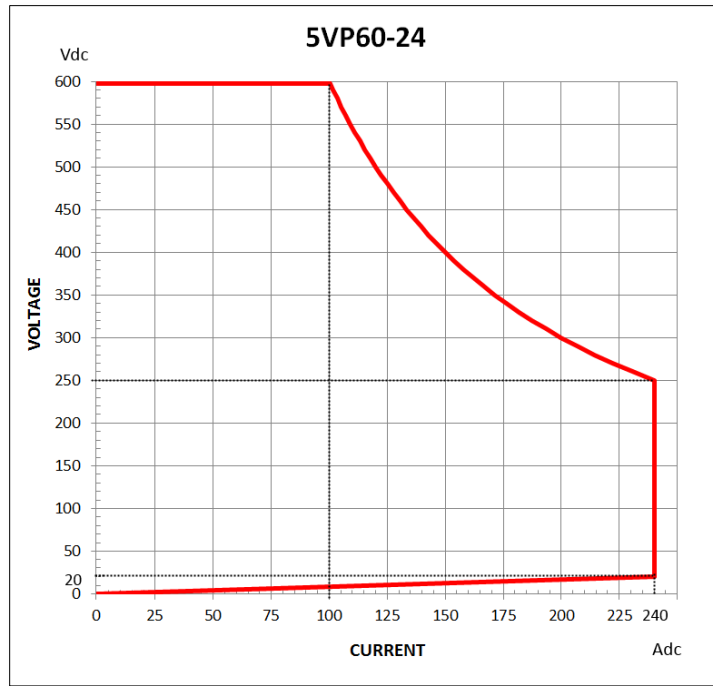

4.11.16 Model 5VP05-05 V-I Curves

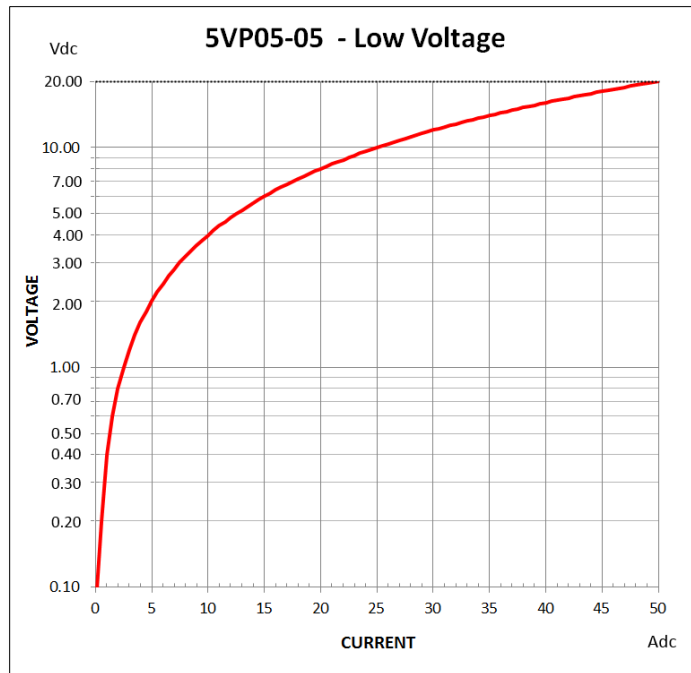
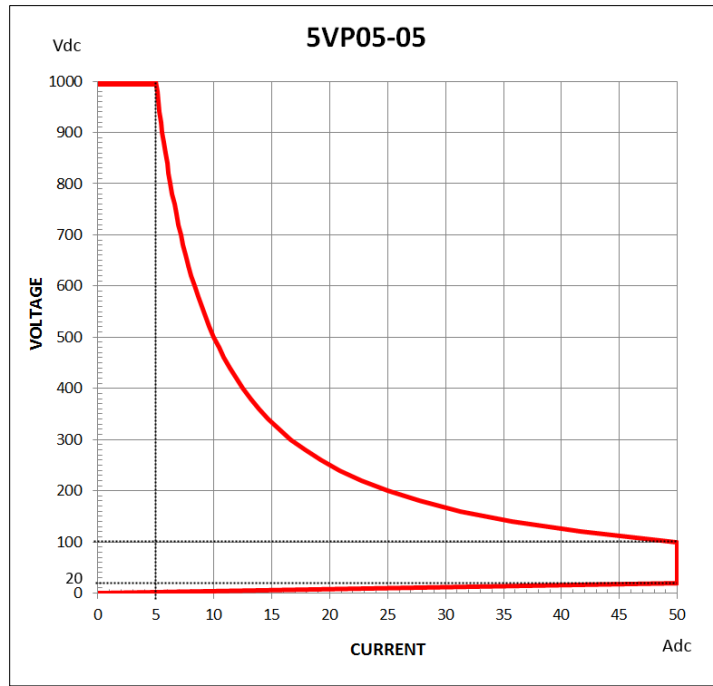

4.11.17 Model 5VP10-10 V-I Curves

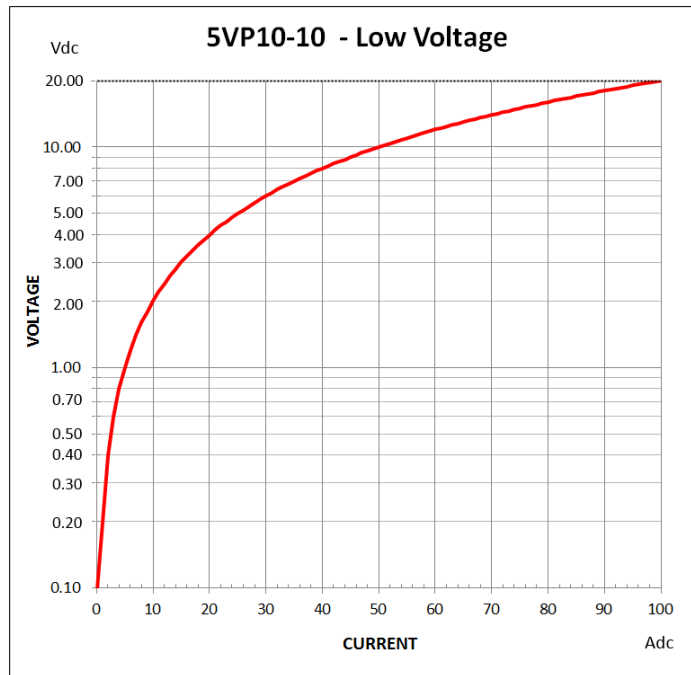
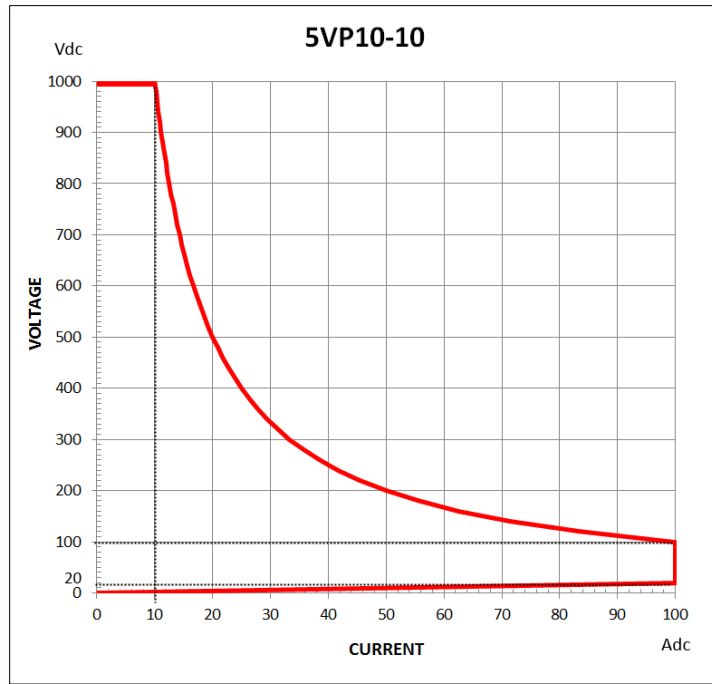

4.11.18 Model 5VP15-15 V-I Curves

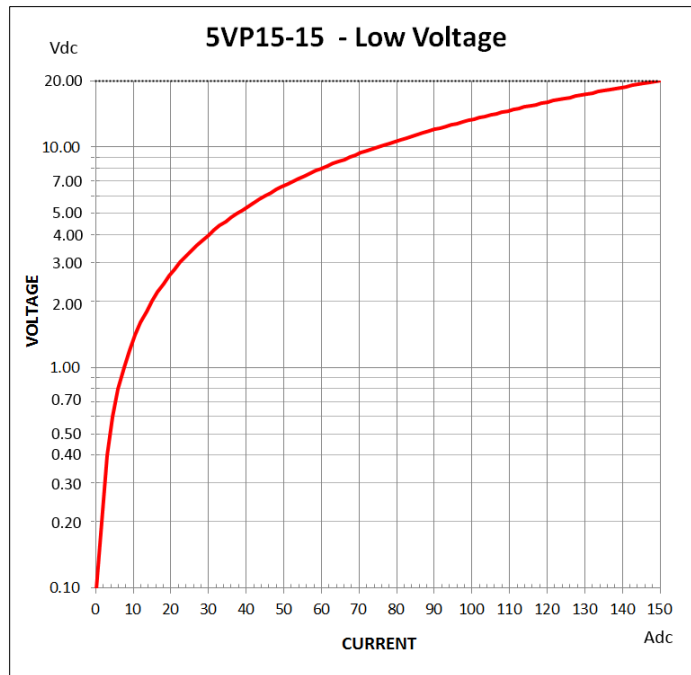
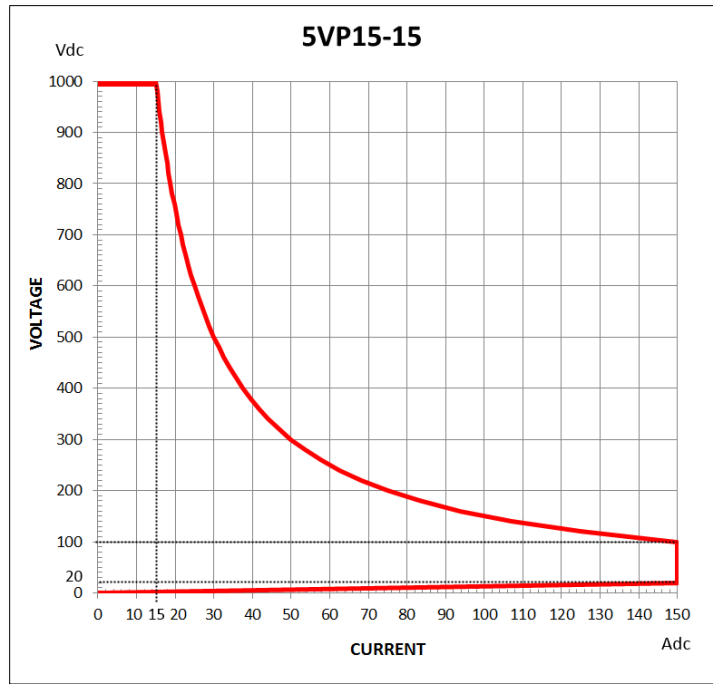

4.11.19 Model 5VP20-20 V-I Curves

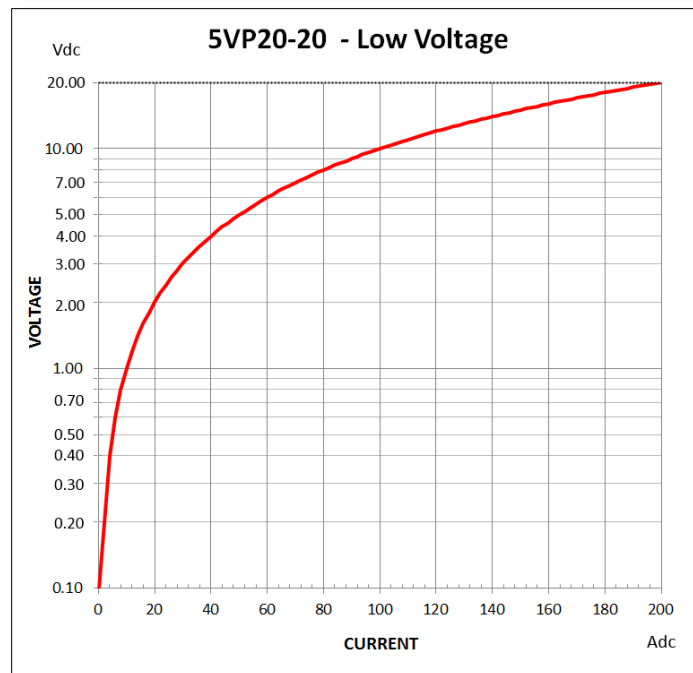
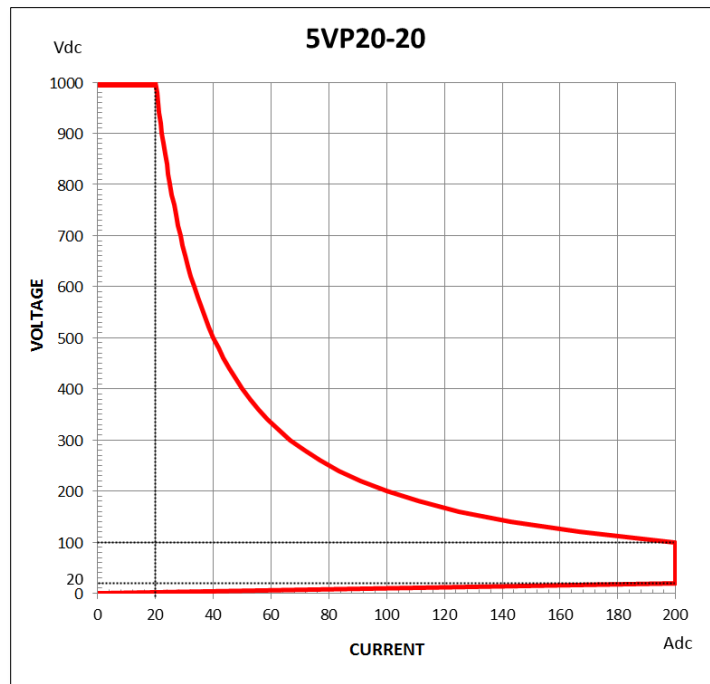

4.11.20 Model 5VP25-25 V-I Curves

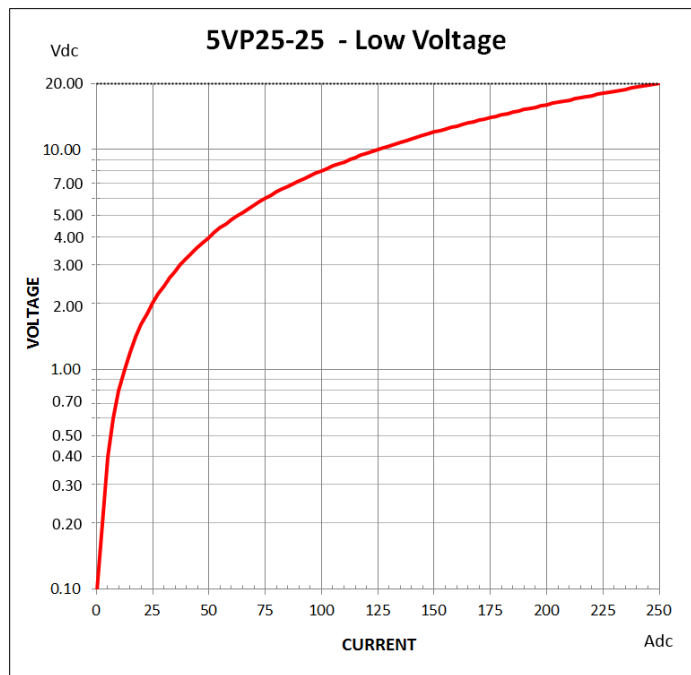
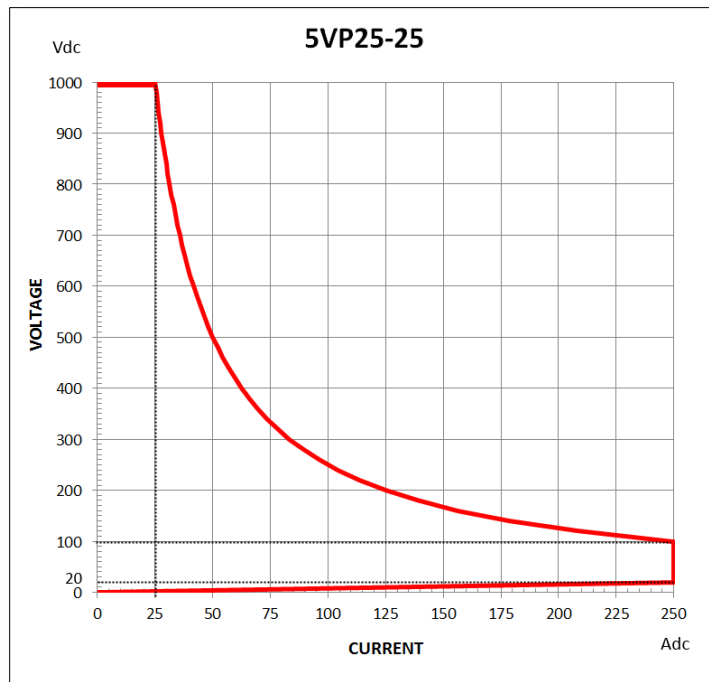

4.11.21 Model 5VP30-30 V-I Curves

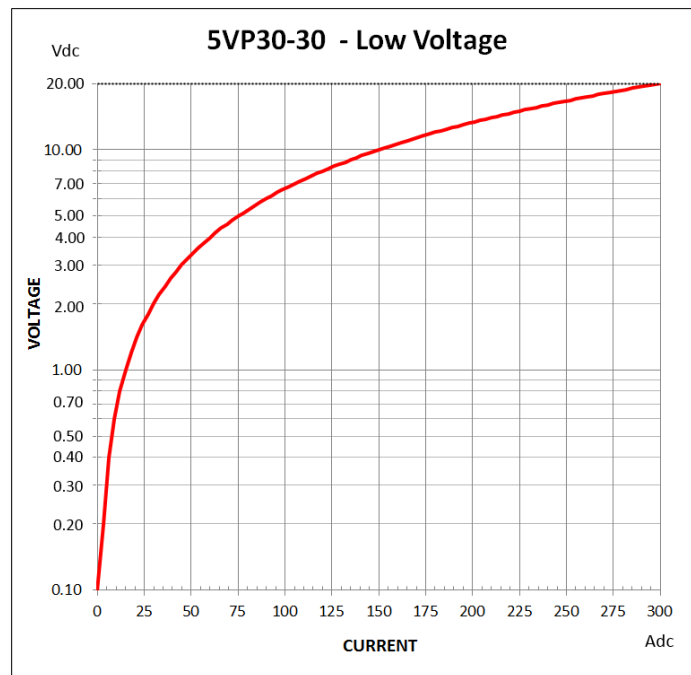
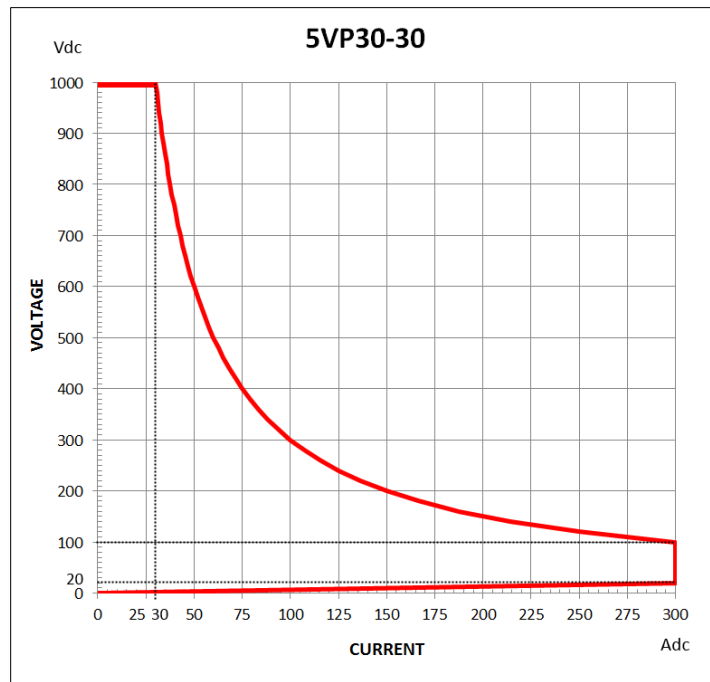

4.11.22 Model 5VP35-35 V-I Curves

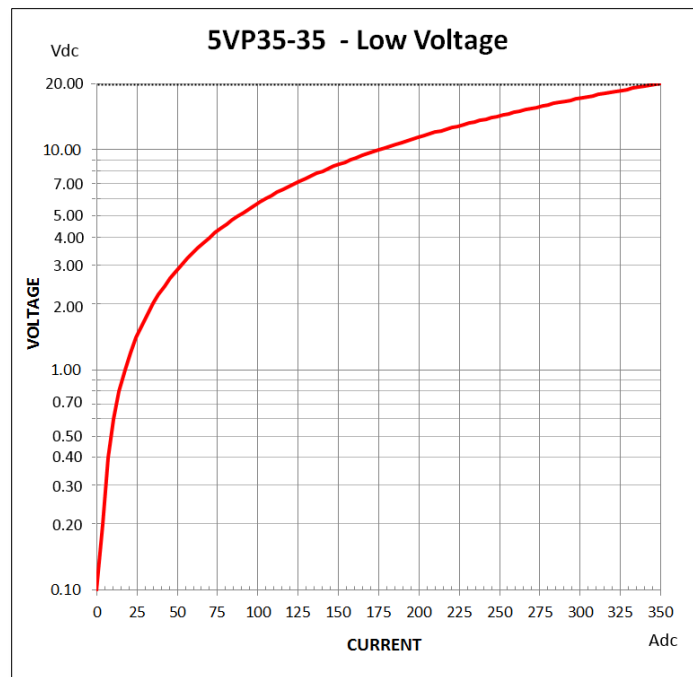
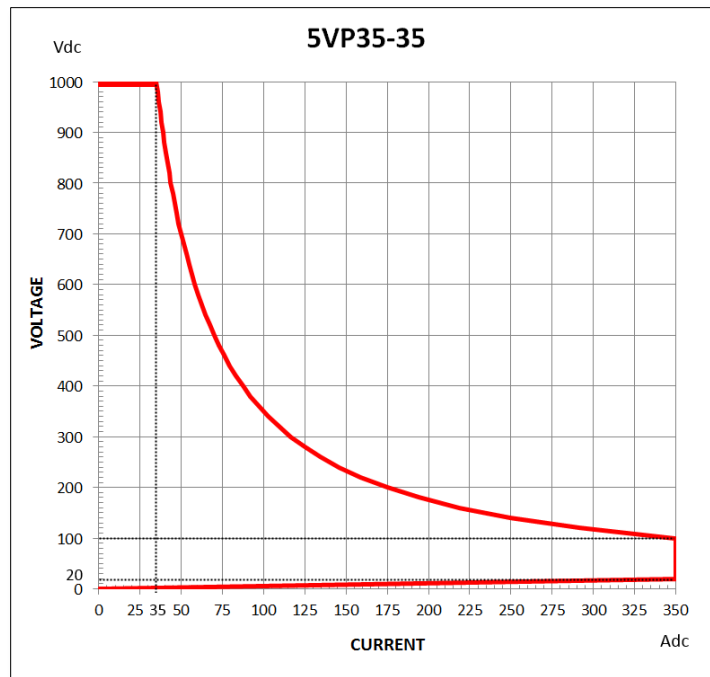

4.11.23 Model 5VP40-40 V-I Curves

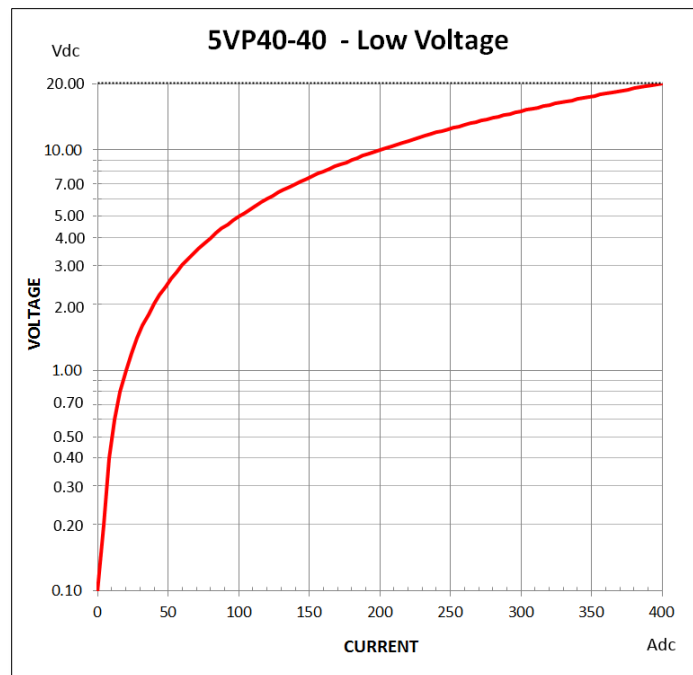
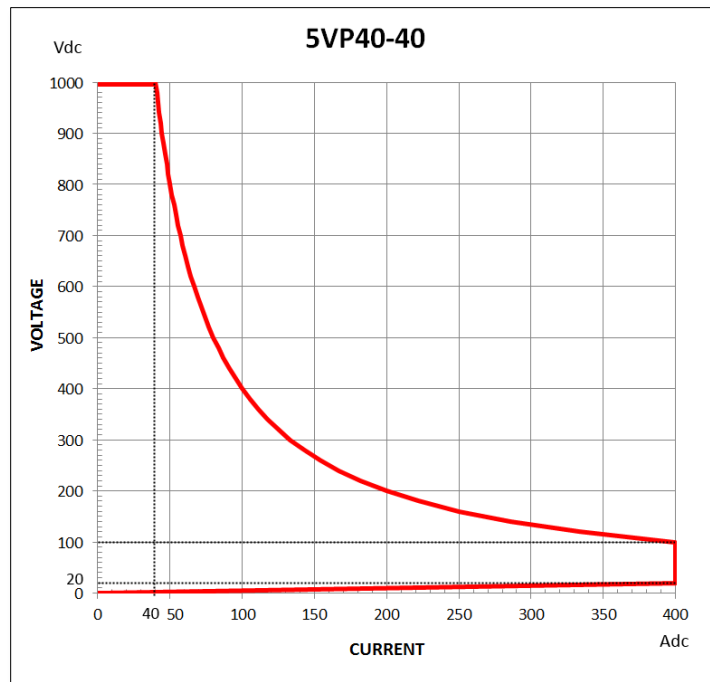

4.11.24 Model 5VP50-50 V-I Curves

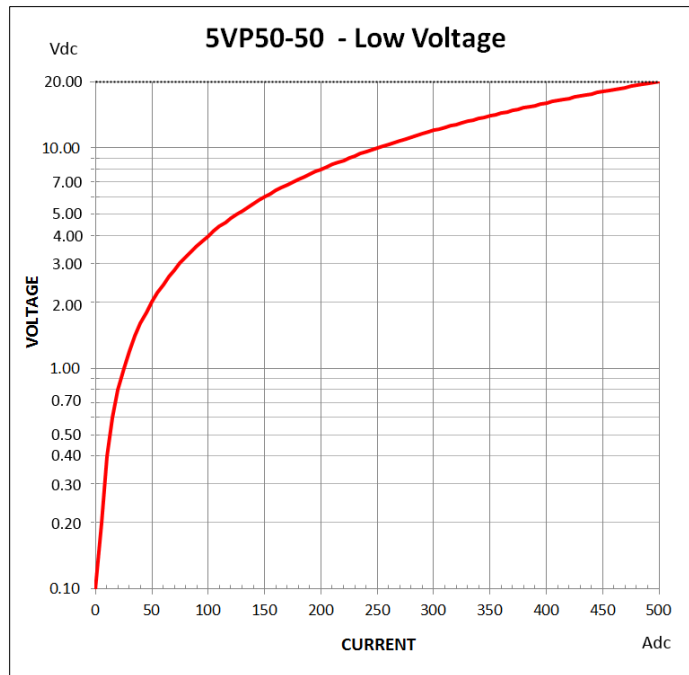
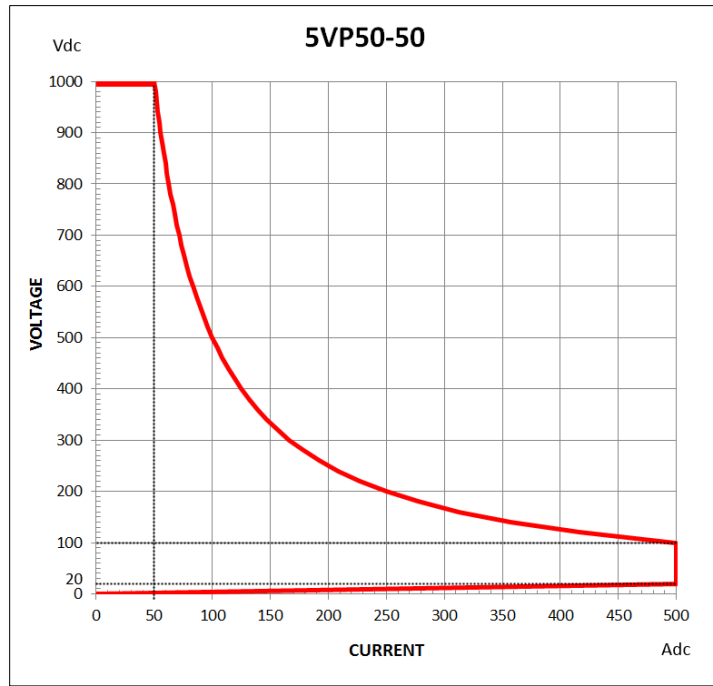

4.11.25 Model 5VP60-60 V-I Curves

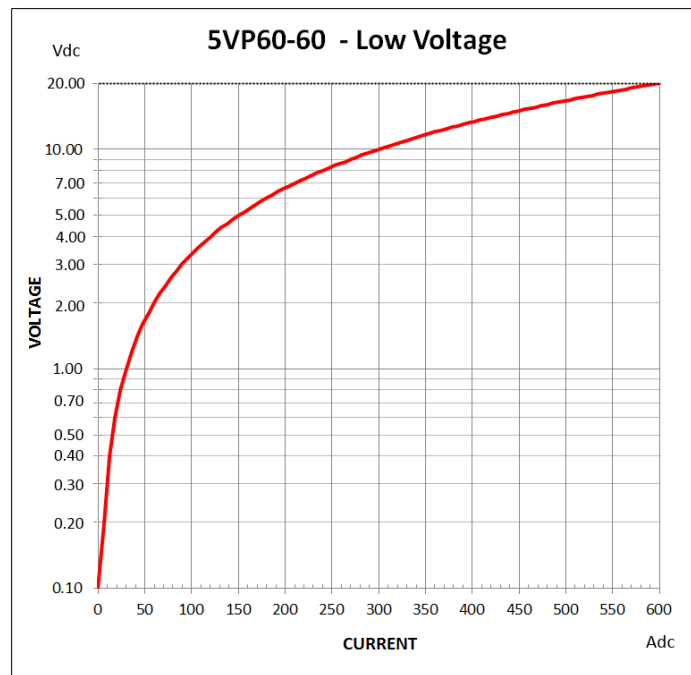
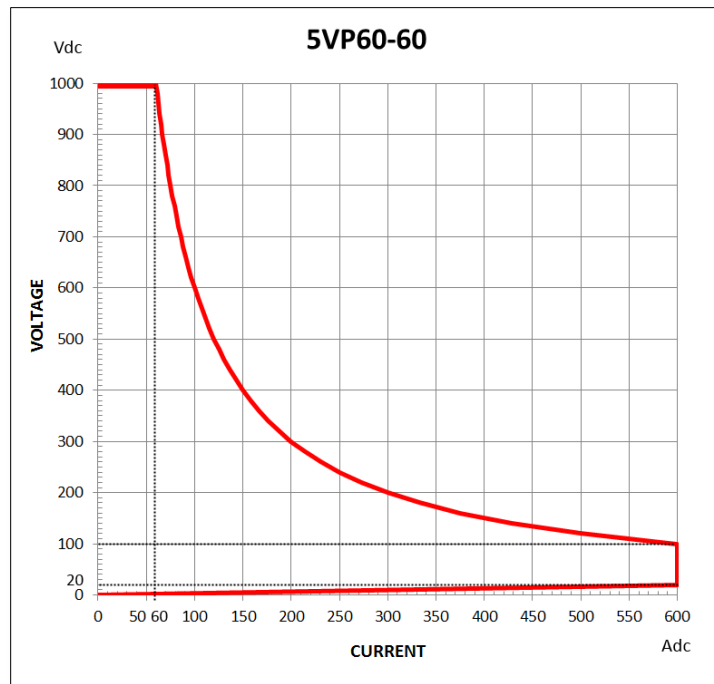

## 5 Unpacking and Installation

### 5.1 Inspection

The 5VP Series Cabinet DC loads are carefully inspected before shipment. If instrument damage has occurred during transport, please inform Adaptive Power Systems' nearest sales and service office or representative.

Your DC load was shipped with a power cord for the type of outlet used at your location. If the appropriated cord was not included, please contact your nearest sales office to obtain the correct cord. Refer to "check line voltage" to check the line voltage selection and fuse type.

### 5.2 Check Line Voltage

The 5VP Series Cabinet load can be operated with a 100Vac to 240Vac or a 208Vac to 240Vac single phase AC input depending on model as indicated on the label on the rear panel. Make sure that the line input range corresponds to your nominal line voltage.

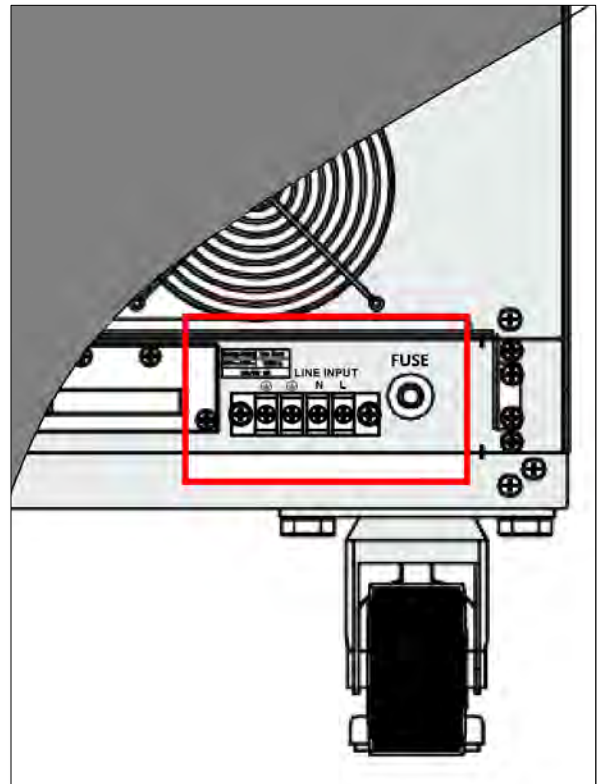



Figure 5-2: AC Input Rating Label and Terminal Locations

### 5.3 Input Fuse

This product is fitted with a mains input fuse. If it needs to be replaced, always replace the input fuse with the same type and rating fuse.

CAUTION

**BEFORE replacing the fuse you must switch off the unit and mains power outlet and disconnect the AC power cable.**

WARNING

**If prior to exchanging the fuse, there is any abnormal noise or odor, do not use the unit. Please inform your local sales office to arrange for repair of the unit.**

**To avoid the risk of fire or electronic shock the fuse must only be replaced with same type and rating as the original. Any replacement fuse used should meet local national safety standards. Any use of an improper fuse or shorting the Fuse holder is extremely dangerous and is strictly prohibited.**

## 5.4 Grounding Requirements



The unit is grounded via the AC Input. A line cord with proper Earth Ground pin must be used at all times. Correct grounding of your electrical system infrastructure according to applicable national standards must also be observed.

## 5.5 Cleaning

To clean this product uses a soft or slightly damp cloth.

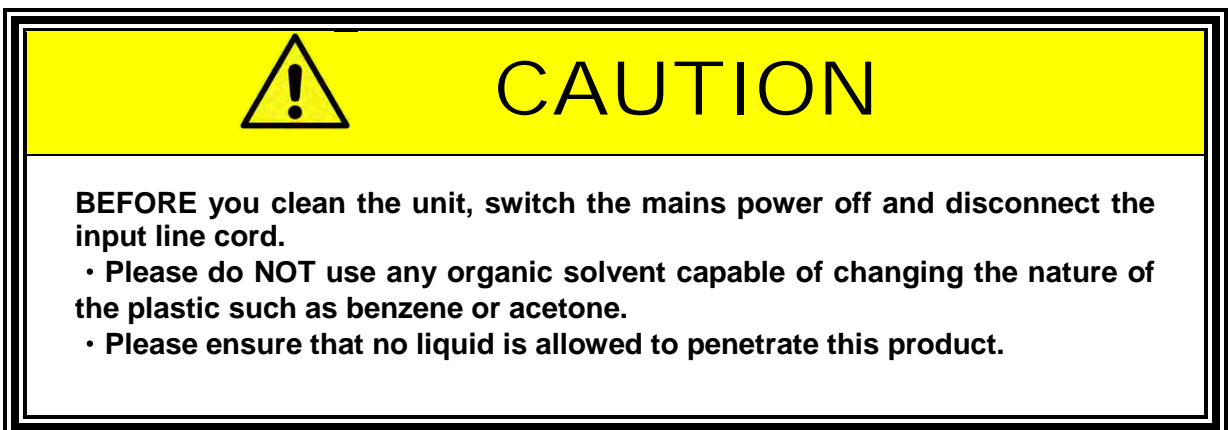

## 5.6 Powering Up

The following procedure should be followed before applying mains power:

1. Check that the POWER switch – located at the upper right front of the cabinet is in the OFF (O) position.
2. Verify that the rear panel voltage selector of the chassis is correctly set.
3. Check that nothing is connected to any of the DC INPUT (load input terminals) on the front and/or rear panels.
4. Connect the correct AC mains line cord to the 5VP Series Cabinet load AC input terminal.
5. Plug the line cord plug into a suitable AC outlet socket.

6. Turn on (I) the POWER switch.
7. If the instrument does not turn on for some reason, turn OFF the POWER switch and verify the presence of the correct AC line input voltage using appropriate safety measures.

### 5.7 In Case of Malfunction

In the unlikely event of an instrument malfunction or if the instrument does not turn on despite the presence of the correct AC line voltage, please attach a warning tag to the instrument to identify the owner and indicate that service or repair is required. Contact Adaptive Power Systems or its authorized representative to arrange for service.

### 5.8 Load Connection

 **WARNING**

### DO NOT EXCEED LOAD INPUT VOLTAGE RATING

**This instrument does NOT have a means to disconnect its Load input from a connected power supply. If the voltage applied to the Load input exceeds its maximum rating – even if the load is turned completely off – damage to the load WILL occur. Damage caused by exceeded maximum load input voltage under any circumstance is NOT covered by the manufacturer’s product warranty. Remove any load input connections when the load is not in use, even when it is turned off.**

When setting up for a new test and connecting any equipment to the DC load, proceed as follows:

1. Always make sure the DC load is turned OFF at the POWER switch when making any wire connections.
2. Check that the output of the equipment under test is **OFF**.  
**Note:** Some power equipment’s output may still be energized even if the equipment has been turned off or its output is turned off. This is especially true for DC power supplies.  
  
**Note:** When working with batteries, it is recommended to provide a suitable disconnect relay or switch so the load connection can be disconnected from the battery for handling purposes.
3. Connect one end of the load wires to the load input terminals on the rear panel.

4. Check the polarity of the connections and connect the other end of the load wires to the output terminal of the equipment under test.
5. When connecting multiple loads to the same EUT, makes sure the load wire lengths to each load are the same.

## 5.9 Interface Options

The 5VP Series Cabinet supports one of four different remote control interface options. The interface specified at the time of order is installed at the factory prior to shipment. It is possible to retrofit interface options in the field. Contact Adaptive Power Systems Customer Service for instructions.

### 5.9.1 RS232 Serial Interface

Figure 5-3 shows the RS232 connector (Female) on the rear panel. This connects the load unit to an RS232 port of a computer. The RS232 BAUD-RATE can be set on the front panel of the load. Press the “SYSTEM” button twice to enter the desired BAUD RATE adjustment.



Figure 5-3: RS232 Connection

### 5.9.2 GPIB Interface

The GPIB connector is located on the rear panel. This socket allows the load to be connected to the controller and other GPIB devices. A GPIB system can be connected in any configuration (star, linear, or both) as long as the following conditions are met:

- The maximum number of devices including the controller is equal or less than 15.
- The maximum length of the GPIB cable is no more than 2 meters.
- The total lead length of all devices connected together totals less than 20 meters.
- Please make sure the lock screws are firmly hand-tightened, use a screwdriver only for the removal of screws. Figure 5-4 shows the rear panel of load. The GPIB address of the load is set on the front panel.

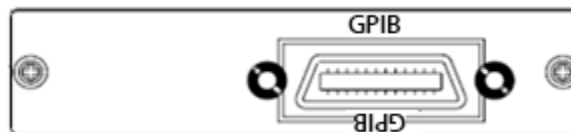

Figure 5-4: GPIB Connection

### 5.9.3 USB Interface

The 5VP Series load uses a USB Type B connector on the rear panel when equipped with the USB interface option. Figure 5-5 shows the USB connector at the rear panel of the load. Please refer section 9, “USB Driver Installation” for information on USB communications.



Figure 5-5: USB Connection

### 5.9.4 LAN Interface

The LAN option uses a 100BaseT Ethernet interface. Figure 5-6 shows the LAN connector on the rear panel of the load. Please refer to section 10, “LAN Driver Installation” for information on LAN communications.



Figure 5-6 LAN Connection

### 5.9.5 GPIB & RS232 Combination Interface

Figure 5-7 shows the combination GPIB & RS232 connectors (Female) on the rear panel. Note that only one interface can be used at a time. In all aspects, these interfaces are identical to the ones covered in sections 5.9.1 and 5.9.2.

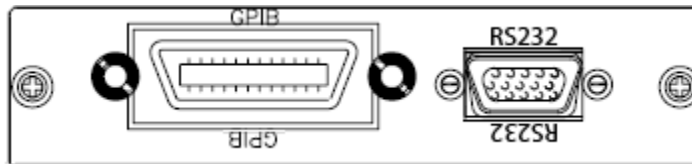

Figure 5-7: RS232 Connection

## 5.10 Analog Programming Input

The 5VP Series has an analog programming input. This feature allows an external waveform to be tracked as long as it is within the load's dynamic capabilities. The analog programming input is available through a BNC terminal on the rear panel. This input will accept a 0-10V signal. This signal is proportional to the load's maximum current range.

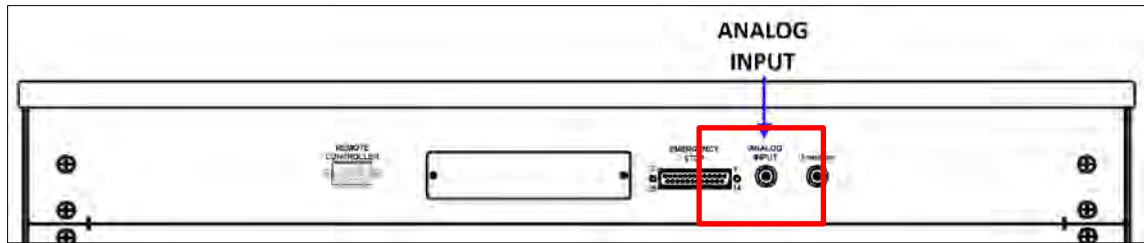

Figure 5-8: Location of Analog Programming Input Connector on 5VP Unit

The analog programming input operates in CC or CP modes only. The load will attempt to load proportionally according to the signal and the load's maximum current or power range.

For example: 5VP10-32:  $I_{max} = 320A$  and  $P_{max} = 10.000W$

- In CC mode, if the analog programming input is 4V, the load current will be  $0.4 \times 320A = 128A$ .
- In CP mode, if the analog programming input is 1V, the load power setting will be  $0.1 \times 10,000W = 1000W$ .

The analog programming signal can act alone or it can be summed with the programmed value set via the front panel or the optional computer interface (GPIB, RS232, USB, or LAN) or the front panel.

Figure 5-9 shows the result of an analog programming signal at 4Vac, 500Hz when it is summed with a 128A programmed setting in CC mode of DC load.

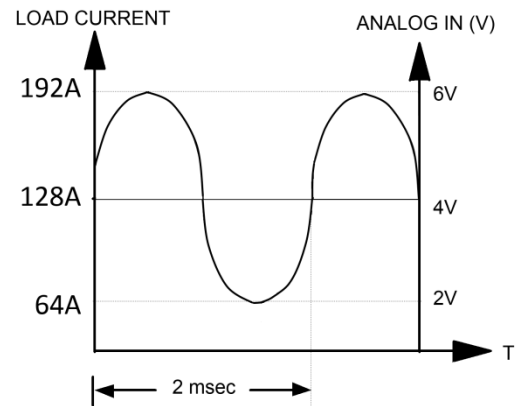
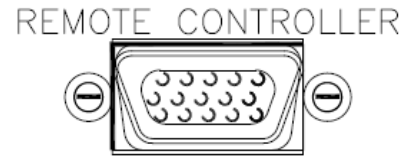

Figure 5-9: Analog Programming Input Example

### 5.11 Remote Controller Interface

The 5VP Series load recall keys can be operated remotely using an optional external keypad. This keypad connects to a DB15 connector on the rear panel of the load. (See illustration to the right.



The equivalent circuit diagram for the remote controller is shown in the figure below.

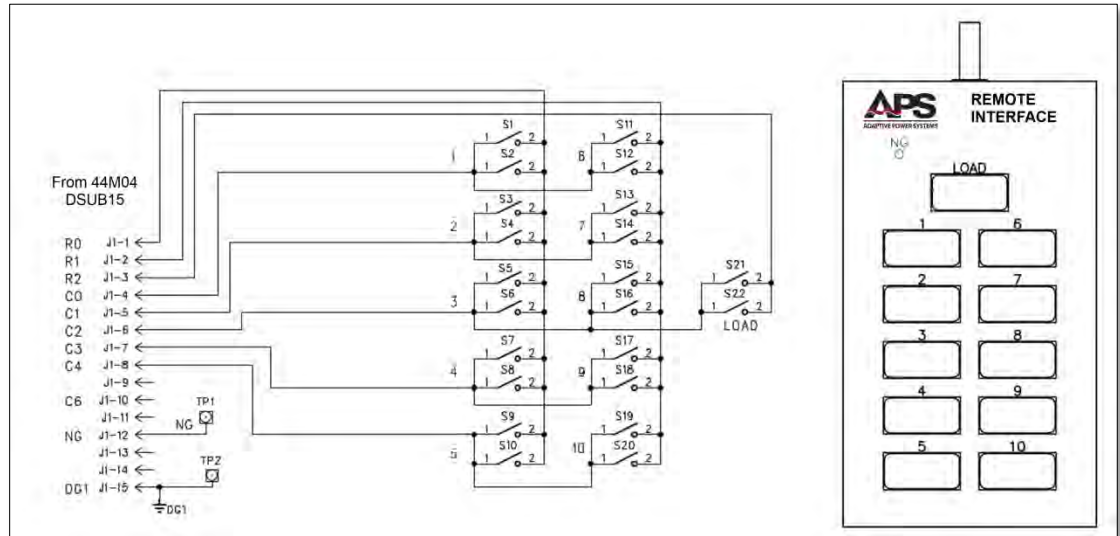
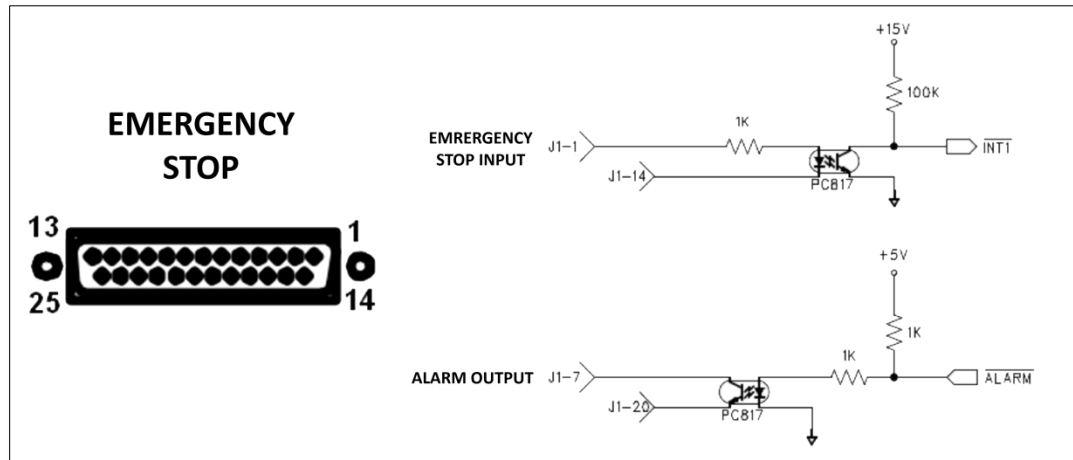

Figure 5-10: Remote Controller Connection

## 5.12 Emergency Stop

The 5VP Series electronic load provides an emergency stop signal input and alarm signal output interface on the rear panel. The I/O connector is a female D-Sub 25. The emergency stop input signal and alarm output signal are optically isolated.



The emergency stop input signal is active low. When the emergency stop input goes to low, the load will go to the load “off” state immediately.

The alarm signal output is active low. This output signal is active when any protection mode is active (OVP, OCP, OPP, OTP). The load will go to the load “off” immediately as a result of any of these conditions.

### 5.13 Load Current Slew Rate

The programmable current slew rate of the DC load allows control over the rate of change in current any time a change in current occurs. This controls the load current slew rate during load current level changes, power supply turn ON/OFF events or when turning the LOAD ON, and OFF. The 5VP Series loads provide controlled current slewing under all of these conditions. The rise and fall current slew rate can each be set independently.

For example, on model 5VP10-32, the rise and fall slew rates can be independently programmed from 256mA/ $\mu$ sec to 16A/ $\mu$ sec in the 320A current range and from 25.6mA/ $\mu$ sec to 1.6A/ $\mu$ sec in the 32A current range. This allows an independent controlled transition from Low load current level to High load current level ( Rise current slew rate ) or from High load current level to Low load current level( Fall current slew rate ) to minimize induced voltage drops on the wiring inductance, or to control induced voltage transients on the device under test (power supply transient response testing).

See under “DYNAMIC OPERATION, Slew Rate” in the specification section on page 30 for slew rate programming range for other models.

This controllable load current slew rate feature also can eliminate the overload current phenomenon and emulate the actual load current slew rate at turn ON of the power supply under test. Figure 5-11 shows the load current slew rate is according to the power supply's output voltage, load level setting and Load ON/OFF switch.

The ability to apply all these dynamic current characteristics at the same time using the Constant Current mode of the 5VP Series cabinet load greatly speeds up power supply testing tasks. This can significantly improve the test quality, thoroughness and efficiency.

There are two load current ranges in 5VP Series load; Range I and Range II. The rise and fall slews rate range for both current ranges is specified in Section 4.1, “Technical Specifications” on page 30.

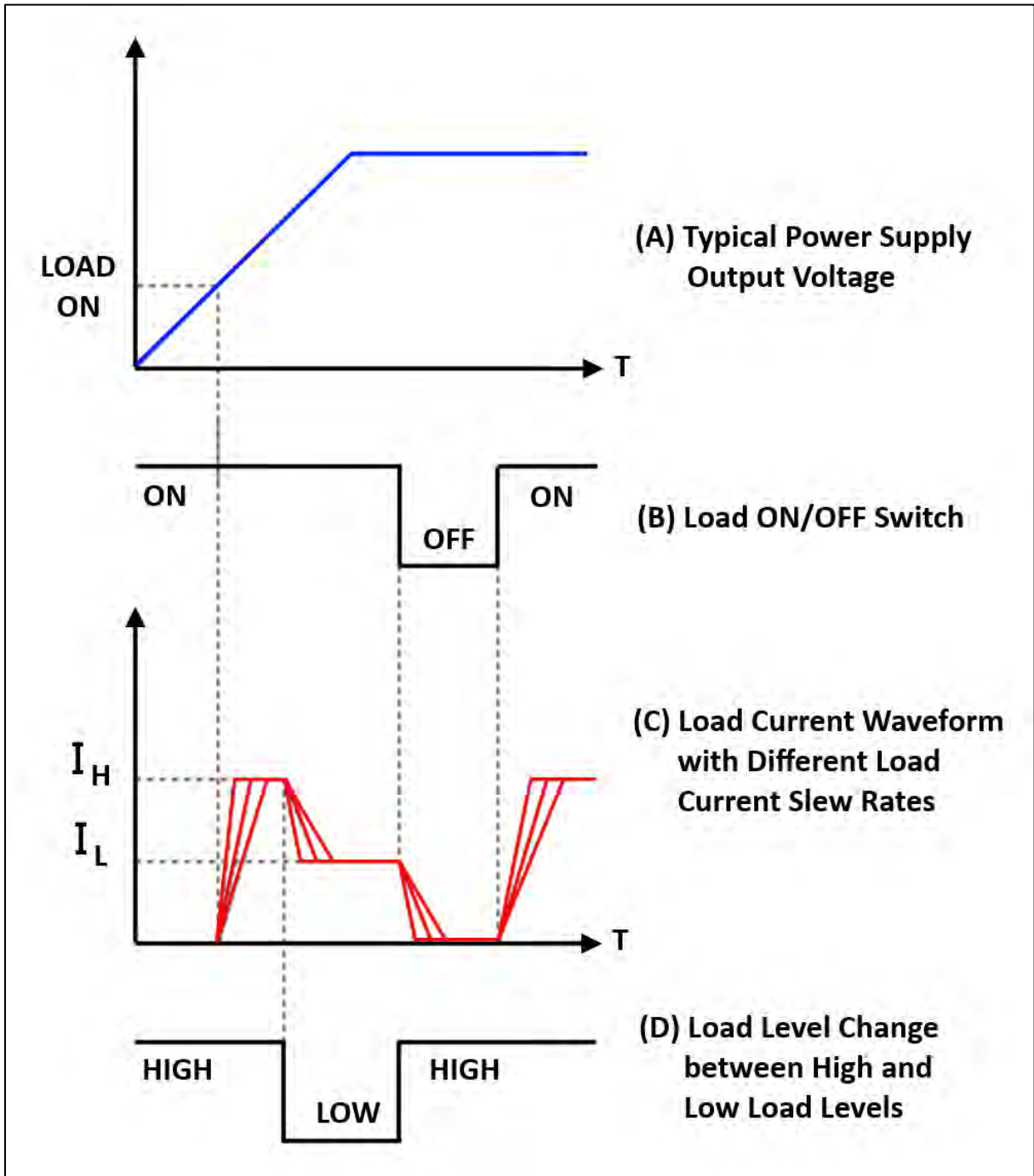

Figure 5-11: Effect of Current Slew Rate Settings on Power Supply Testing

## 6 Front Panel Operation

This Chapter provides an overview of front panel operation for the 5VP Series DC loads. For remote control operation, refer to Section 8 “Remote Control Programming” of this manual for an overview of available programming commands.

### 6.1 Front Panel Layout

The front panel layout of the 5VP Series load is shown in Figure 6-1 below. The displays and controls are located along the top of the cabinet for easy reach. This makes the front panel easily accessible and readable.



Figure 6-1: 5VP Series DC Load Front Panel View

Large LCD readouts are located on the left. User controls are located to the right of these displays. The power ON/OFF switch is found in the lower left corner of the LCD display area.

The entire front section of the front panel is left clear to allow ambient air to enter for cooling purposes. Air is exhausted at the rear of the unit aided by a series of variable speed fans.

**Note:** For optimal cooling, the air intake section on the front panel should not be blocked in any way. Also, some clearance of at least 6 inches / 15 cm should be allowed at the back of the cabinet from any wall or other obstruction so air can move freely through the load.

## 6.2 User Controls and Readouts

The following user controls, indicators and displays are common to all 5VP Series load models. The purpose and function of each control and indicator is explained in the table below. Refer to figure for the location of each control and indicator.

### 6.2.1 Front Panel Overview



- |  |   |
|--|---|
| <ol style="list-style-type: none"> <li>1. Model Number and ranges</li> <li>2. Go/NoGo indicator and REMOTE state indicator.</li> <li>3. Operating Mode Indicators</li> <li>4. Multi-purpose 5 digit display - Voltage</li> <li>5. Multi-purpose 5 digit display - Current</li> <li>6. Multi-purpose 5 digit display - Power</li> <li>7. Power On/Off Switch</li> </ol> | <ol style="list-style-type: none"> <li>8. MODE selection key</li> <li>9. LOAD ON/OFF button and indicator</li> <li>10. Shuttle Knob, parameter selection and slewing</li> <li>11. DYNAMIC mode button and indicator</li> <li>12. High or Low Range Selection and indicator</li> <li>13. Numeric keypad and cursor keys</li> <li>14. Start/Stop, SHORT, OCP and OPP Test keys and indicators</li> <li>15. System Key Area</li> </ol> |
|--|---|

Figure 6-2: Front Panel User Controls and Indicators

### 6.2.2 Displays and Annunciators

There are three large LED backlit liquid crystal displays (LCD) located on the left hand side of the front panel. These displays will show setting and measurement values using large numeric readouts. The same displays contain a series of annunciators along the top edge that maybe on or off depending on operating mode or status of the load.

The image bellow shows these displays with all numeric segments and annunciators ON to provide an overview. In actual operation, these will never all be on at the same time.

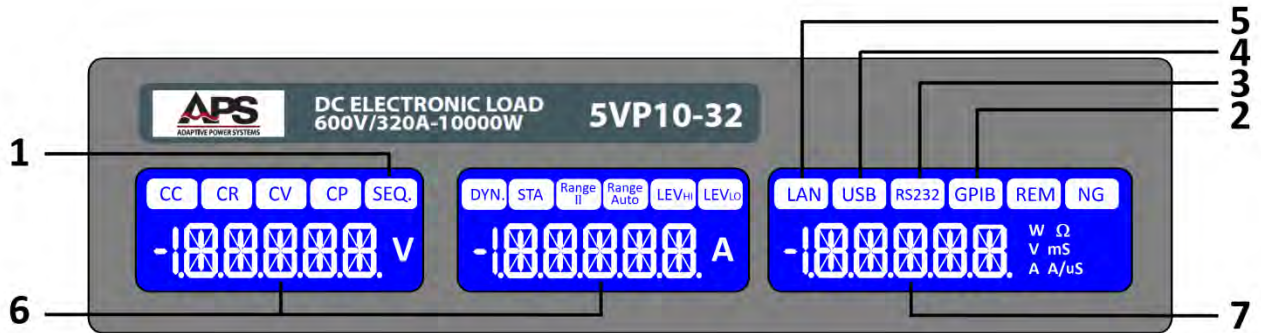

- |   |  |
|---|--|
| <ol style="list-style-type: none"> <li>1. Indicates AUTO SEQUENCE mode is active</li> <li>2. Indicates GPIB interface is active</li> <li>3. Indicates RS232 interface is active</li> <li>4. Indicates USB interface is active</li> <li>5. Indicates LAN/Ethernet interface is active</li> </ol> <p><b>Note:</b> When in Remote State, the REM indicator will be on. In this case, the front panel keys are locked out</p> | <ol style="list-style-type: none"> <li>6. The left most two LCD display will show Mode and Parameter when in any settings menu or AUTO SEQUENCE mode</li> <li>7. The right most display will show parameter values when in any settings menu</li> </ol> <p><b>Note:</b> When the load is active, these three display will show measurements data in Volts, Amps and Watts from left to right</p> |
|---|--|

Left Display Annunciators:

- CC** = Constant Current mode is active
- CR** = Constant Current mode is active
- CV** = Constant Voltage mode is active
- CP** = Constant Power mode is active
- SEQ** = See item 1. Above

Center Display Annunciators:

- DYN.** = Dynamic CC mode is active
- STA** = Static CC mode is active
- Range II** = Load in locked to high voltage and current ranges
- Auto Range** = Load is auto ranging
- LEV<sub>HI</sub>** = Set value displayed applies to High Level
- LEV<sub>LO</sub>** = Set value displayed applies to Low Level

Right Display Annunciators

- LAN, USB, RS232, GPIB** (see above)
- REM** = Load is in remote mode. Keyboard is lock out. Releasing the keyboard by pressing the "Local" key is possible but only if the Local Lockout (LLO) command was not sent over the digital interface.
- NG** = Indicates voltage, current or power is outside user configured limits.

Figure 6-3: LCD Displays Segments and Annunciators

#### 6.2.2.1 Model Number

The APS model number for the load model and its maximum operating range are shown on the model label. Voltage, Current and Power cannot exceed the model ratings by more than 5% of indicated range or a fault will be generated.

Note that the maximum power rating implies that voltage and current have to operating below a constant current curve. Refer to the V-I curves for each model in section 4.11 "Voltage versus Current Operating Envelope Charts" starting on page 45 for specific details.

#### 6.2.2.2 NG Indicator

The user can adjust upper and lower limits for voltage, current and power from the LIMIT menu and turn the NG Indicator ON or OFF. If any voltmeter, current meter or wattmeter measurement is outside these user set limits, the NG indicator will illuminate.

#### 6.2.2.3 MODE Indicators

The load can operate in one of four operating modes as described in section 3.2, "Operating Modes" on page 15. The desired mode can be selected by pressing the "Mode" key successively to toggle through the available modes. The sequence is "CC" → "CR" → "CV" → "CP" and back around. The selected operating mode is indicated on the left hand display.

#### 6.2.2.4 REM (Remote) Indicator

If the REMOTE LCD Indicator is illuminated, the unit is operating remotely via one of the optional remote control interfaces. While REMOTE is lit, it is not possible to change settings manually from the front panel. The "Local" key and used to return control back to the front panel. If however a local Lockout (LLO) command was issued over the remote control interface, the Local key is disabled and front panel operation cannot be released from the front panel.

When the unit is operating from the front panel, the REM annunciator is off.

#### 6.2.2.5 Left LCD Display Information

The left hand side display is multi-purpose and its content depends on the state of the load. Possible states are:

- Normal Operation
- SHORT test
- OCP test
- OPP test

#### **Normal Mode Display – Voltage**

In normal mode, the left display shows the sensed DC input voltage to the load. The readout will include load cabling voltage drop between the load input terminals and the equipment under test (EUT) *only* if external sense mode is selected and the external sense leads are connected at the voltage source.

If the V Sense mode is set to “AUTO” and the sense leads are connected to the EUT, the load cable voltage drop must be at least 700mV before the voltage measurement readout will be compensated for any voltage drop.

If the V Sense mode is set to “ON and the sense leads are connected to the EUT, the voltage measurement readout will always be compensated for any voltage drop.

### **Test Mode Displays**

If either the “Short”, “OCP” or “OPP” keys are pressed, the left display will show the selected test mode as “SHORT”, “OCP” or “OPP” respectively. In this mode, test parameters can be edited and saved. Once a test is started using the red “Start/Stop” key, the left display will revert back to displaying the DC input voltage.

#### 6.2.2.6 Center LCD Display Information

The center display is multi-purpose and its content depends on the state of the load. Possible states are:

- Normal Operation
- Setting Mode

### **Normal Mode Display – Current**

In normal mode, the center display shows the DC current being sunk by the load when the load is in **ON**.

### **Setting Mode Display**

If either the “Config”, “Limit”, “DYN”, “Short”, “OCP” or “OPP” keys are pressed, the center display displays the selected setting mode text. Refer to section 6.2.5”, Function Keys” on page 94 for operating instructions for each setting.

#### 6.2.2.7 Right LCD Display Information

The right hand side display either displays the measured power when the load is in normal mode or a parameter when in one of the available setting modes.

Possible states are:

- Normal Operation
- Setting Mode

### **Normal Mode Display – Power**

In normal operation mode, the right display shows the measured power in watts when the load is in **ON**.

### **Setting Mode Display**

If any setting mode is active, the right display shows set value the selected parameter and allows the user to adjust the setting using the up ▲ or down ▼ arrow keys, shuttle or the numeric keypad. The center display shows what parameter is being adjusted.

### 6.2.3 Keyboard Overview

The front panel key contains several logical groupings of keys making operation of the load more intuitive:

Area	Purpose
<b>System Keys:</b>	Access System setting like selected interface, go to local and setup recall
<b>Function Keys:</b>	Dedicated keys to invoke specific modes and setting
<b>Test Keys:</b>	Access to built-in test modes for OCP, OPP and SHORT testing
<b>Entry Keys:</b>	Parameter entry using decimals 0 through 9, period, clear and "Enter". Also include Up/Down cursor keys

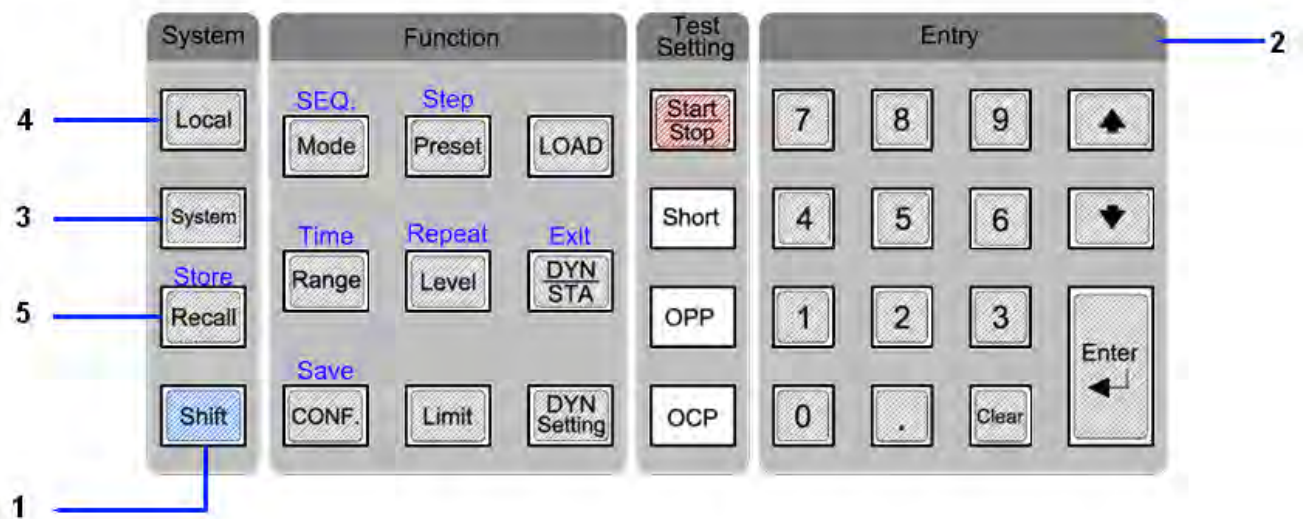

### 6.2.4 System Keys and Numeric Entry Keys

The System keys and numeric keypad are explained in more detail in the table below. The Item numbers correspond to the indices in Figure above.

Key #	Description
1	The Shift key selects the secondary function for any keys that have blue silkscreen above them. Press the Shift key first to place the keyboard in SHIFT mode and then press the desired function key to select its secondary function. Pressing a key with no additional silkscreen has no effect.
2	Numeric key pad. May be used to enter number parameters values and select STORE and RECALL memory locations.

Key #	Description
3	<p>SYSTEM key will allow the following system menu to be selected:            GPIB → RS232 → WAKE UP SETTING → SEQUENCE BUZZER → Exit            The sequence of SYSTEM screens is shown below. For setup instructions, see table rows 3.1 through 3.6.</p>
	<p>The diagram illustrates the sequence of screens accessed via the SYSTEM key. Each screen displays the APS logo, 'DC ELECTRONIC LOAD 600V/320A-10000W', and the model '5VP10-32'. The menu options shown are:</p> <ul style="list-style-type: none"> <li>Screen 1: GPIB, Addr, 5</li> <li>Screen 2: RS232, bAUD, 1152k</li> <li>Screen 3: WAKE, UP, 0</li> <li>Screen 4: SEQ, bEEP, OFF</li> <li>Screen 5: CC, 500.00 V, STA, 0000 A, LEV, 00 W</li> </ul>

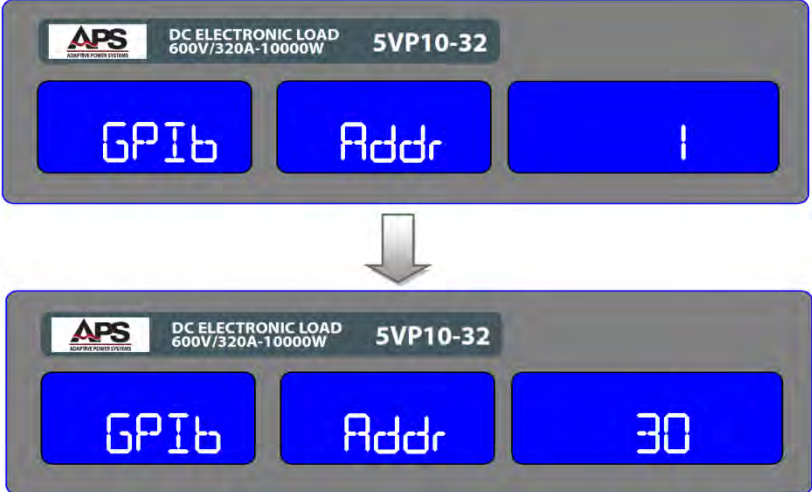
Key #	Description
<b>System Setting Instructions:</b>	
3.1	<p><b>GPIB</b></p> <p>To set the GPIB address, press the <b>“System”</b> key once. The left display will show <b>“GPIB”</b>, the center display will show <b>“Addr”</b> and the right display shows the current GPIB address setting.</p> <p>Use the up ▲ or down ▼ arrow keys, shuttle or the numeric keypad to set the address to the desired setting. Available setting range is 0 through 30.</p>  <p>To save the address value, press the <b>“System”</b> key four times to exit the menu.</p>

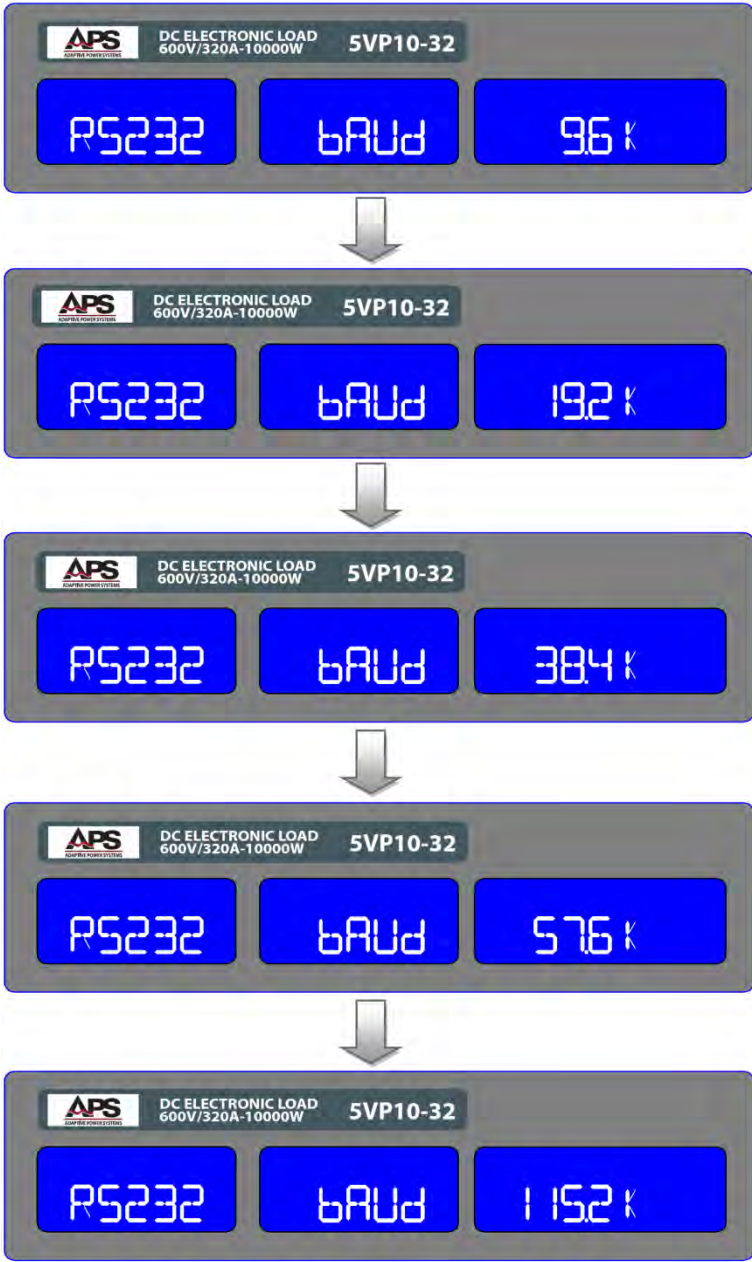
Key #	Description
3.2	<p><b>RS232</b></p> <p>To set the RS232 baud rate, press the “System” key twice. The left display will show “RS232”, the center display will show “bAUd” and the right display shows the current baudrate setting.</p> <p>Use the up ▲ or down ▼ arrow keys to increment or decrement the baudrate to the desired setting. Available setting range is 9.6kBaud through 115.2kBaud.</p> <div style="text-align: center;">  </div> <p>To save the address value, press the “System” key three times to exit the menu.</p>

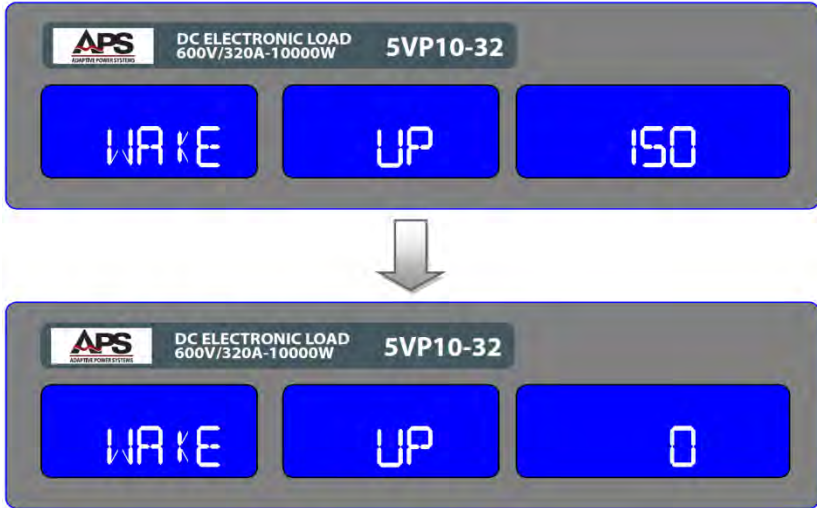
Key #	Description
3.3	<p><b>USB</b></p> <p>For USB interface configuration settings, refer to Section, 9, "USB Driver Installation" on page 203.</p> <p><b>Note:</b> When using USB, set the RS232 baudrate to the highest available setting.</p>
3.4	<p><b>LAN</b></p> <p>For LAN interface configuration and setup, refer to Section 10, "LAN Driver Installation" on page 206.</p> <p><b>Note:</b> When using LAN, set the RS232 baudrate to the highest available setting.</p>
3.5	<p><b>WAKE-UP</b></p> <p>The wake-up mode determines how the load powers up. This</p> <p>To set the wake-up state, press the "<b>System</b>" key three times. The left display will show "WAKE", the center display will show "UP" and the right display shows the current setting.</p> <p>Use the up ▲ or down ▼ arrow keys, shuttle or the numeric keypad to select the setup memory to recall at power on. Available setting range is 0 through 150. To disable the wake-up function, select memory location zero (0). In this case, the load will power up with factory default settings. Refer to section 6.4, "Initial Power-on Settings" on page 140 for factory default settings by load model.</p> <p><b>Note:</b> Make sure the desired power on settings are stored in the selected wake-up memory location.</p> <div style="text-align: center;">  </div> <p>To save the wake-up memory location, press the "<b>System</b>" key two times to exit the menu.</p>

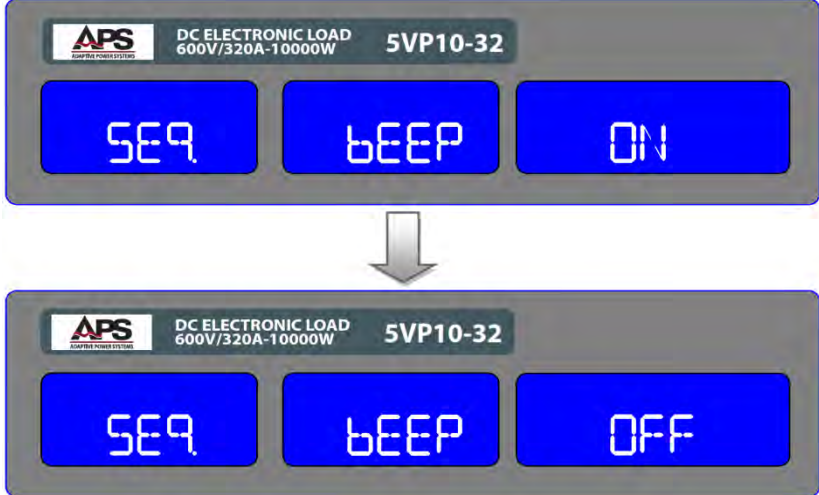
Key #	Description
3.6	<p><b>BUZZER</b></p> <p>When enabled, the buzzer will sound when an AUTO TEST SEQUENCE completes. If the test result is FAIL, the buzzer will sound a second time to indicate a failed result.</p> <p>To set the buzzer mode, press the “System” key four times. The left display will show “SEQ”, the center display will show “bEEP” and the right display shows the current setting as either “ON” or “OFF”.</p> <p>Use the up ▲ or down ▼ arrow keys to toggle between “ON” or “OFF” state. Press the keypad “Enter” button to confirm this setting or it will not be saved when exiting this menu.</p> <div style="text-align: center;">  </div> <p>Press the “Enter” key to confirm new setting and then the “System” key one time to exit the menu.</p>
4	<p>Press the LOCAL key to return the load to local mode (front panel) operation. This will take the load out of remote (REM) state and the REM indicator will turn off.</p> <p>Note: If the Local Lockout (LLO) command was sent over the digital control interface, the LOCAL key is disabled and front panel operation can only be released over the control interface.</p>
5	<p>The “Recall” and “Store” (Shift-Recall) allow access to 150 non-volatile load setups or load STATES. This features allows for high throughput testing by recalling various load settings without have to manually change settings at each step.</p>
5.1	<p><b>STORE</b></p> <p>To store an new instrument STATE, set the load to the desired mode and high and low parameter levels. Once the requires setup is achieved, press the “Shift” key, then the “Recall” key to enter storage mode.</p> <p>Use the up ▲ or down ▼ arrow keys, shuttle or the numeric keypad to select the STATE memory location and press the keypad “Enter” button to confirm this setting or it will not be saved.</p>
5.2	<p><b>RECALL</b></p> <p>To recall an existing instrument STATE, press the “Recall” key to enter recall mode. Use the up ▲ or down ▼ arrow keys, shuttle or the numeric keypad to select the STATE memory location and press the keypad “Enter” button to recall this setting. The new settings take effect immediately.</p>

### 6.2.5 Function Keys

The function keys provide direct access to load controls and settings and are labeled as such. The table below describes the purpose and function of each key in detail.

#### 6.2.5.1 MODE Key

The mode key selects the load operating mode. There are four modes and the “**Mode**” key cycles through them in the following sequence:

“CC” → “CR” → “CV” → “CP” and back around

The mode annunciator for the selected mode is shown on the left LCD display. Refer to section 3.2, “Operating Modes” on page 15 for a description of each mode.

#### 6.2.5.2 LOAD Key and Indicator

The input of the electronic load is enabled by pressing the “**Load**” key once. It is disabled by pressing the “**Mode**” key again. The load input status is shown by the illumination of the “**Load**” key itself. When lit, the load is ON, when not, it is OFF.

- Turning the load ON and OFF does not affect the programmed preset values. When the load ON state is enabled, the unit will start sinking current or power according to the preset values.
- When the load ON/OFF key is operated, the current drawn by load will follow the rise or fall with time according to the programmed current slew rates. The current rise and fall times can be adjusted using the “**DYN**” key of the front panel.
- In addition to using the load ON/OFF key, the user can also adjust the voltage level at which the load will automatically start or stop sinking current. The adjustable LDon and LDoFF voltage levels can be found in the CONFIG Menu.

**Note:** The LDoFF level cannot be set higher than the LDon Level.

#### 6.2.5.3 DYN/STA Key and Indicator

The “**DYN/STA**” button allows the user to switch between DYNAMIC operation and STATIC operation. Dynamic operation is only possible in constant current (CC) or constant power (CP) mode. The DYN/STA button will be lit when DYNAMIC operation is selected. If the load is in constant resistance (CR) or constant voltage (CV) mode, pressing the DYN button will have no effect.

#### 6.2.5.4 RANGE Key and Indicator

The 5VP load supports two operating ranges for all operating modes; low (RANGE I) or high (RANGE II) range. This allows improved resolution for lower setting values. When left in the AUTO mode (default), the load automatically switches between high or low range depending on the set value entered. If needed, the “**Range**” button can be pressed to force the unit to operate only in the high range (RANGE II) when in CC mode. This is indicated by the “**Range**” key being lit.

**Note:** Forcing the load in Range II is only possible in CC mode.

#### 6.2.5.5 LEVEL Key and Indicator

The “**Level**” button is used to program the high and or low load set value used in the dynamic mode. The setting value applies to either current, resistance, voltage or power depending on the selected load operating mode. If the “**Level**” key is lit, the high level value setting can be adjusted. If the “**Level**” key is not lit, the low load level can be adjusted. Use the up ▲ or down ▼ arrow keys, shuttle or the numeric keypad to adjust either value.

- In STATIC mode, the user can switch between high and low load levels during normal operation using the “Level” key.
- In DYNAMIC operation (applicable to CC & CP modes only) the preset high and low levels are used to define the dynamic current waveform.

**Note:** the low level setting cannot exceed the high level setting and the high level cannot be set below the low level.

#### 6.2.5.6 PRESET key and Indicator

The “Preset” key will put the load in preset mode. In this mode, setting parameter values can be preset without taking effect yet. The “Preset” key will be lit when the load is in this mode. The parameter value that can be change depends on the selected load operating mode. The right hand side display will change from displaying the measured power to displaying the selected preset parameter:

- CC Mode: High and low levels for current can be set. The “A” annunciator will be shown.
- CR Mode: High and low levels for resistance can be set. The “Ω” annunciator will be shown.
- CP Mode: High and low levels for power can be set. The “W” annunciator will be shown.
- CV Mode: High and low levels for voltage can be set. The “V” annunciator will be shown.

When in Dynamic CC or CP mode, each press of the “**DYN Setting**” key will cycle through the dynamic setting parameters for the current waveform. The dynamic settings are used in combination with the high and low level settings. Pressing the “DYN Setting” repeatedly will cycle through the dynamics setting parameters in the following sequence:

“T-hi” (time at high level) → “T-Lo” (time at low level) → “Rise” (rise time) → “Fall” ( fall time) → Exit. Refer to screen sequence shown on next page.

The center LCD shows the parameter selected. The right LCD shows the set value. Use the up ▲ or down ▼ arrow keys, shuttle or the numeric keypad to adjust setting values.

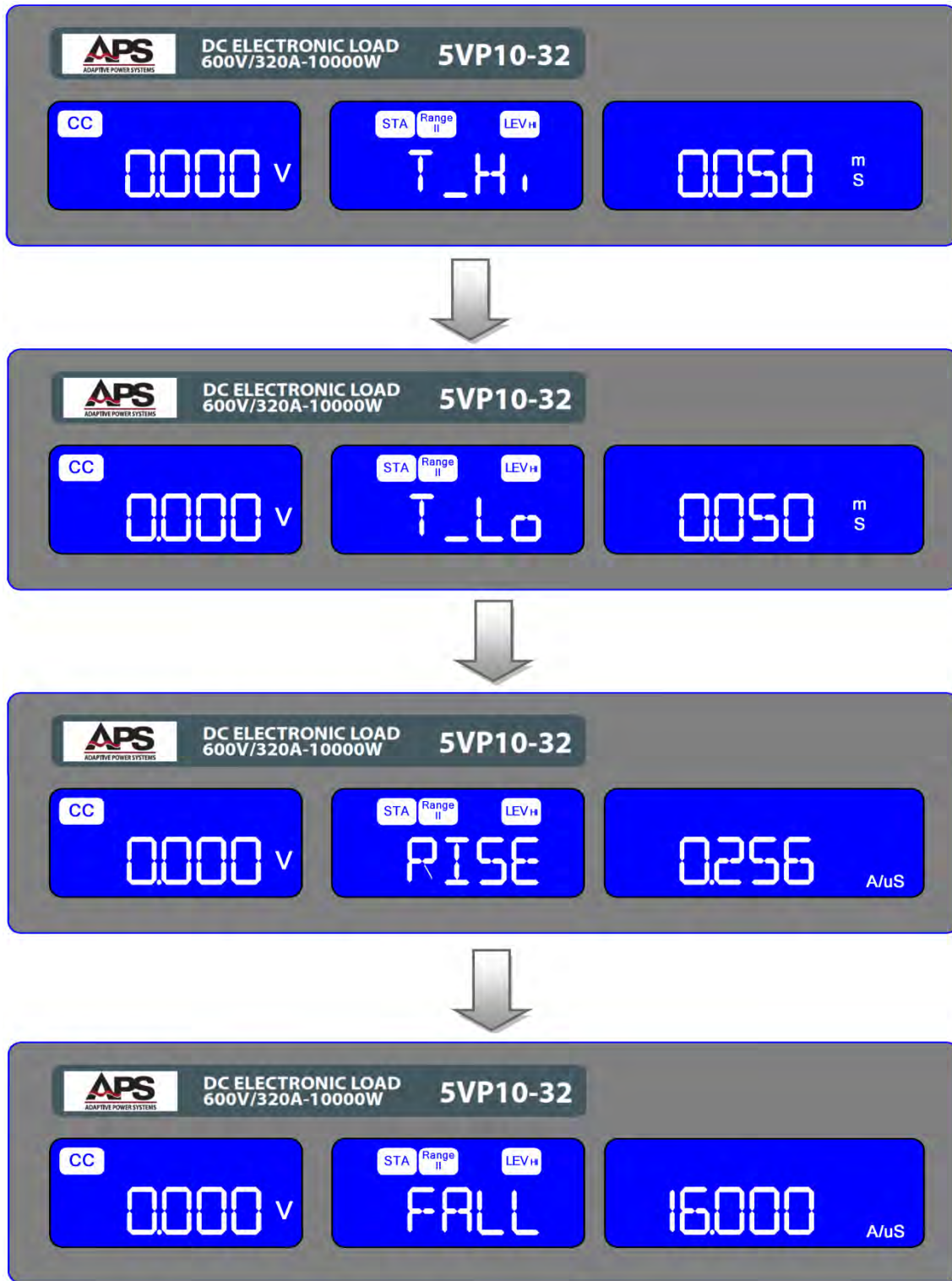
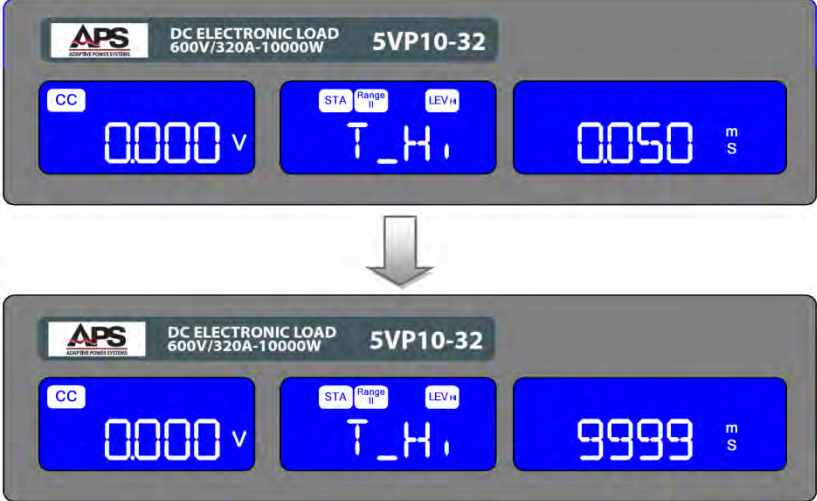

Figure 6-4: DYN Setting Parameter Setting Screens

6.2.5.7 DYN Setting Key and Indicator

The “**DYN Setting**” key allows the user to define the timing of the dynamic load waveform. The high and low levels of load current are set using the “**Level**” key. All other dynamic waveform settings are made using the “**DYN Setting**” screens.

The “**DYN Setting**” key will be lit while in the setting mode. The center LCD shows the parameter selected. The right LCD shows the set value. Use the up ▲ or down ▼ arrow keys, shuttle or the numeric keypad to adjust setting values.

DYN Setting	Description
<b>DYN Setting</b>	<p>Press the “<b>DYN Setting</b>” key once to enter the dynamic waveform setup screens. The “<b>DYN Setting</b>” key will illuminate. Pressing the “<b>DYN Setting</b>” key repeatedly will cycle through the dynamics setting parameters in the following sequence:            “T hi” (time at high level) → “T-Lo” (time at low level) → “Rise” (rise time) → “Fall” (fall time) → Exit. The first dynamic waveform setting screen for T_Hi will appear.</p>
<b>T_Hi</b>	<p>The center LCD shows “<b>T_Hi</b>”. The right LCD shows the set value in msecs. Use the up ▲ or down ▼ arrow keys, shuttle or the numeric keypad to adjust the T_Hi setting. Available setting range is 0.050 msec to 9999 msec (9.999 seconds) divided into four ranges:</p> <p>Range 1: 0.050 – 9.999 msec            Range 2: 10.00 – 99.99 msec            Range 3: 100.0 – 999.9 msec            Range 4: 1000 – 9999 msec</p> 

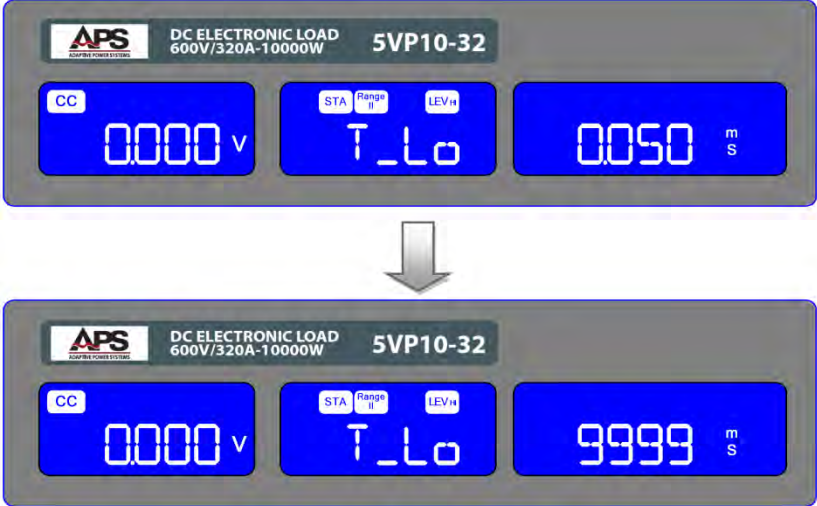
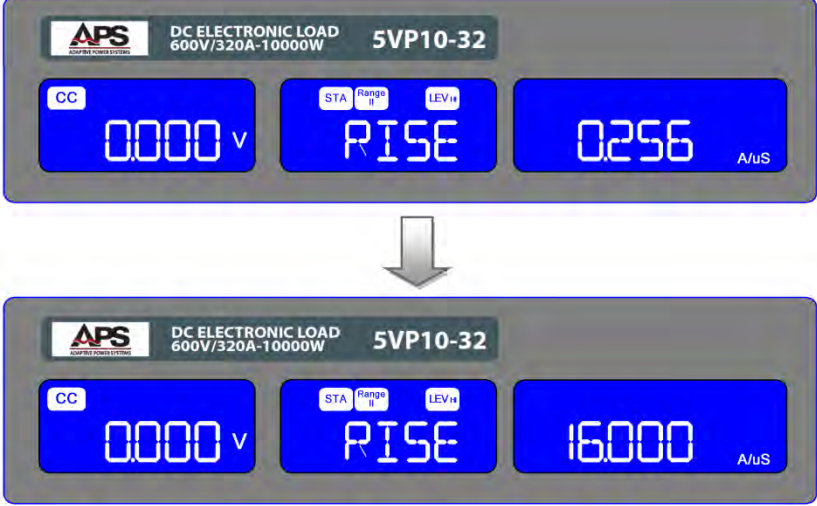
DYN Setting	Description
	<p>Press the “DYN Setting” key again. The center LCD shows “T_Lo”. The right LCD shows the set value in msec. Use the up ▲ or down ▼ arrow keys, shuttle or the numeric keypad to adjust the T_Lo setting. Available setting range is 0.050 msec to 9999 msec (9.999 seconds). Same ranges as for T_Hi.</p>  <p>The image shows two sequential screenshots of the APS 5VP10-32 front panel LCD. The top screenshot shows the 'T_Lo' setting at 0050 mS. The bottom screenshot shows the 'T_Lo' setting at 9999 mS. The LCD displays 'CC' on the left, '0000 V' in the center, and the setting name and value on the right. The setting name 'T_Lo' is shown in the center LCD, and the value '0050 mS' or '9999 mS' is shown on the right LCD. The unit 'mS' is indicated on the right LCD.</p>
	<p>Press the “DYN Setting” key again. The center LCD shows “RISE”. The right LCD shows the set value in A/μs. Use the up ▲ or down ▼ arrow keys, shuttle or the numeric keypad to adjust the rise time setting. Available setting range is 0.256 A/μs to 16 A/μs in 64 mA/μs steps.</p>  <p>The image shows two sequential screenshots of the APS 5VP10-32 front panel LCD. The top screenshot shows the 'RISE' setting at 0256 A/uS. The bottom screenshot shows the 'RISE' setting at 16000 A/uS. The LCD displays 'CC' on the left, '0000 V' in the center, and the setting name and value on the right. The setting name 'RISE' is shown in the center LCD, and the value '0256 A/uS' or '16000 A/uS' is shown on the right LCD. The unit 'A/uS' is indicated on the right LCD.</p>

DYN Setting	Description
<b>FALL</b>	<p>Press the “<b>DYN Setting</b>” key again. The center LCD shows “<b>FALL</b>”. The right LCD shows the set value in A/μs. Use the up ▲ or down ▼ arrow keys, shuttle or the numeric keypad to adjust the fall time setting. Available setting range is 0.256 A/μs to 16 A/μs in 64 mA/μs steps.</p>
<b>Exit</b>	<p>Press “<b>DYN Setting</b>” key to exit the dynamic setting screen. To apply the programmed dynamic current waveform, refer to section 6.2.5.3, “DYN/STA Key and Indicator” on page 94.</p>

### 6.2.5.8 LIMIT Key and Indicator

The limit function of the load allows upper and lower limits to be set for voltage, current and power. When enabled, the load will monitor all measurement data against these limits and signal any excursion outside of these limits as a FAIL as part of its Go/NoGo test function. Using this built-in Go/NoGo function can greatly increase test throughput times in automated test systems as no bus traffic to program or transfer measurement data to a host PC is needed during test runs.



For a further description of the Go/NoGo mode, refer to section 6.2.7, page 134.

The various limit screens are described in the table below.

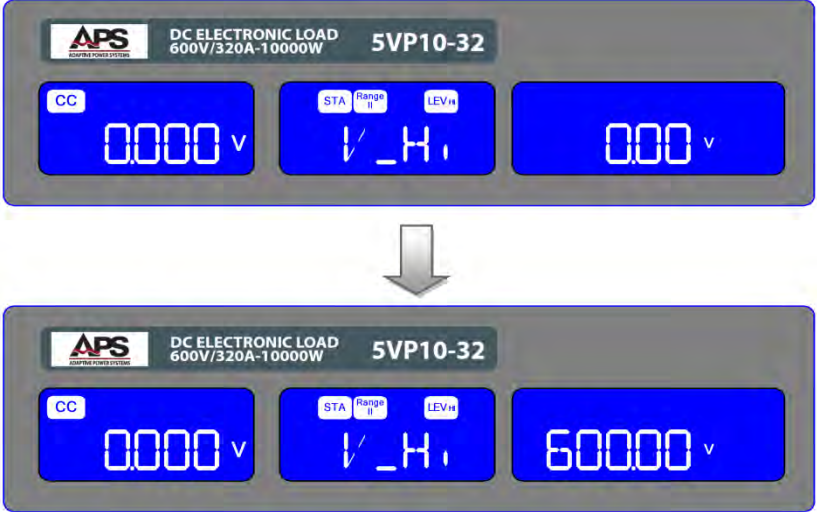
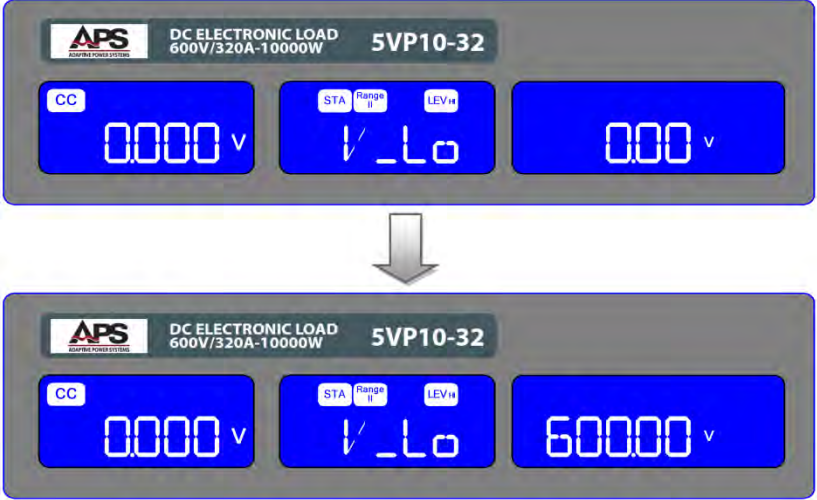
LIMIT	Description
<b>LIMIT</b>	<p>Press the “<b>Limit</b>” key once to enter the limit setup screens. The “<b>Limit</b>” key will illuminate. Pressing the “<b>Limit</b>” key repeatedly will cycle through the limit setting parameters in the following sequence:  “V_Hi” → “V_Lo” → “I_Hi” → “I_Lo” → “W_Hi” → “W_Lo” → “NG OFF/ON” → Exit.  Dimensions for parameters are voltage (V), current (I) and power (W) respectively.</p>

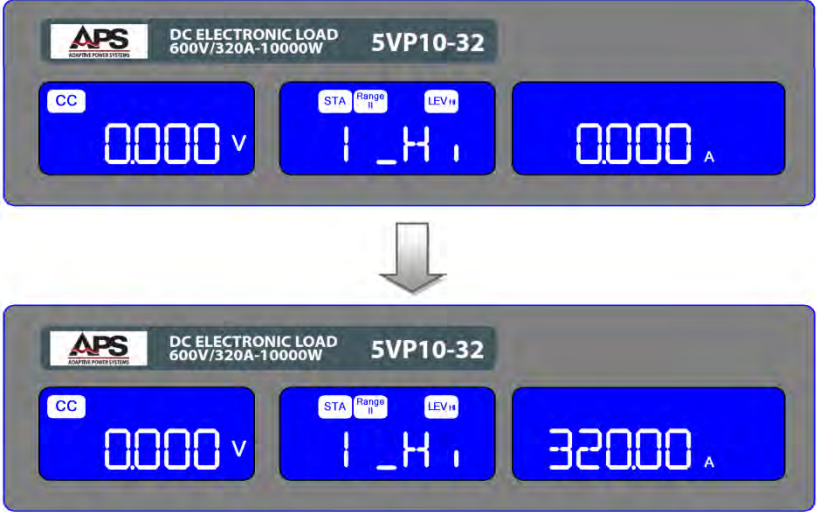
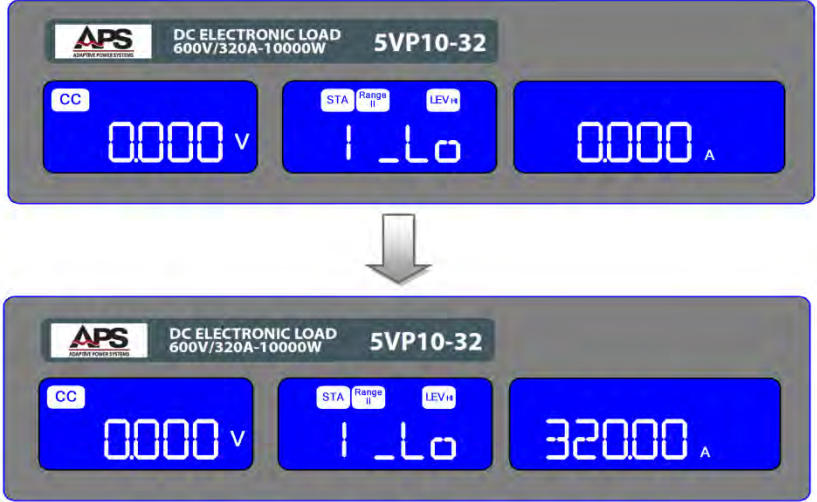
LIMIT	Description
V_Hi	<p>On first press of the “Limit” key, the high voltage limit menu appears. The center LCD display shows “V_Hi”, the right LCD shows the set value in volts. Use the up ▲ or down ▼ arrow keys, shuttle or the numeric keypad to adjust the high voltage limit setting. Available setting range is determined by the load model.</p> 
V_Lo	<p>Press the “Limit” key again to proceed to the low voltage limit setting screen. The center LCD display shows “V_Lo”, the right LCD shows the set value in volts. Use the up ▲ or down ▼ arrow keys, shuttle or the numeric keypad to adjust the low voltage limit setting. Available setting range is determined by the load model.</p> 

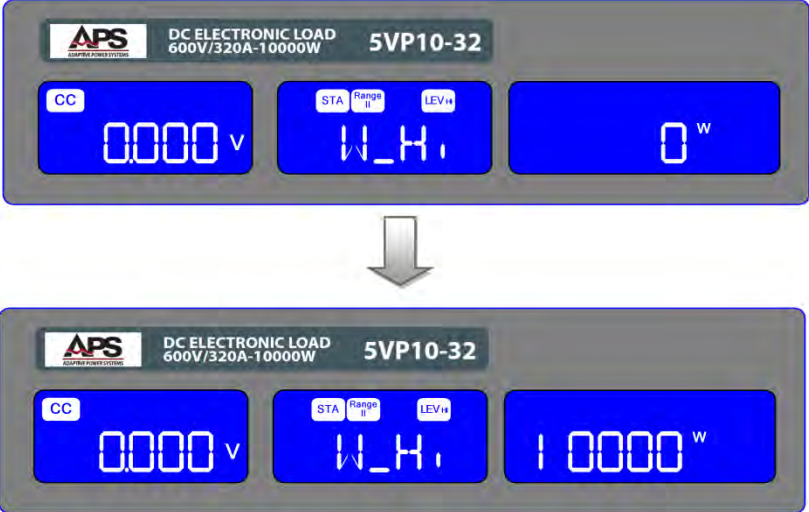
LIMIT	Description	
	<p><b>I_Hi</b></p>	<p>Press the “Limit” key again to proceed to the high current limit setting screen. The center LCD display shows “I_Hi”, the right LCD shows the set value in amps. Use the up ▲ or down ▼ arrow keys, shuttle or the numeric keypad to adjust the high current limit setting. Available setting range is determined by the load model.</p> 
	<p><b>I_Lo</b></p>	<p>Press the “Limit” key again to proceed to the low current limit setting screen. The center LCD display shows “I_Lo”, the right LCD shows the set value in amps. Use the up ▲ or down ▼ arrow keys, shuttle or the numeric keypad to adjust the low current limit setting. Available setting range is determined by the load model.</p> 

LIMIT	Description	
	<p><b>W_Hi</b></p>	<p>Press the “Limit” key again to proceed to the high power limit setting screen. The center LCD display shows “W_Hi”, the right LCD shows the set value in watts. Use the up ▲ or down ▼ arrow keys, shuttle or the numeric keypad to adjust the high power limit setting. Available setting range is determined by the load model.</p>  <p>The diagram illustrates the high power limit setting process. It shows two states of the front panel display. In the first state, the center LCD displays 'W_Hi' and the right LCD displays '0 W'. In the second state, the center LCD displays 'W_Hi' and the right LCD displays '1 0000 W'. A downward arrow indicates the transition between the two states.</p>
	<p><b>W_Lo</b></p>	<p>Press the “Limit” key again to proceed to the low power limit setting screen. The center LCD display shows “W_Lo”, the right LCD shows the set value in watts. Use the up ▲ or down ▼ arrow keys, shuttle or the numeric keypad to adjust the low power limit setting. Available setting range is determined by the load model.</p>  <p>The diagram illustrates the low power limit setting process. It shows two states of the front panel display. In the first state, the center LCD displays 'W_Lo' and the right LCD displays '0 W'. In the second state, the center LCD displays 'W_Lo' and the right LCD displays '1 0000 W'. A downward arrow indicates the transition between the two states.</p>

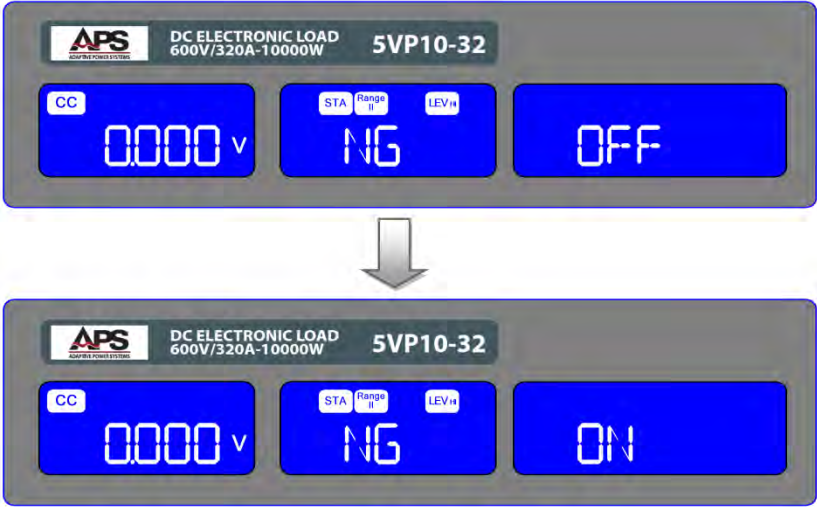
LIMIT	Description
	<p data-bbox="467 302 505 323"><b>NG</b></p> <p data-bbox="610 302 1430 426">Press the “Limit” key again to proceed to the Go/NoGo setting screen. The center LCD display shows “NG”, the right LCD shows the set value as either ON or OFF. Use the up ▲ or down ▼ arrow keys to turn the Go/NoGo mode on or off.</p> <div data-bbox="613 436 1425 940" style="border: 1px solid gray; padding: 10px; text-align: center;">  <p>The image shows two screenshots of the APS 5VP10-32 front panel LCD display. The top screenshot shows the 'NG' mode with 'OFF' on the right display. The bottom screenshot shows the 'NG' mode with 'ON' on the right display. A downward arrow indicates the transition between the two states.</p> </div>
	<p data-bbox="467 959 505 980"><b>Exit</b></p> <p data-bbox="610 959 1240 984">Press the “Limit” key again to exit the Limit setting screen.</p>

6.2.5.9 CONFIG Key and Indicator

The “**Config**” key allows the several load functions to be configured. This includes voltage sense mode, load on and off threshold values, input polarity and several battery test modes. These functions can be accessed by pressing the “**Config**” key repeatedly to access each setup screen in sequence as shown in the screen sequence below.

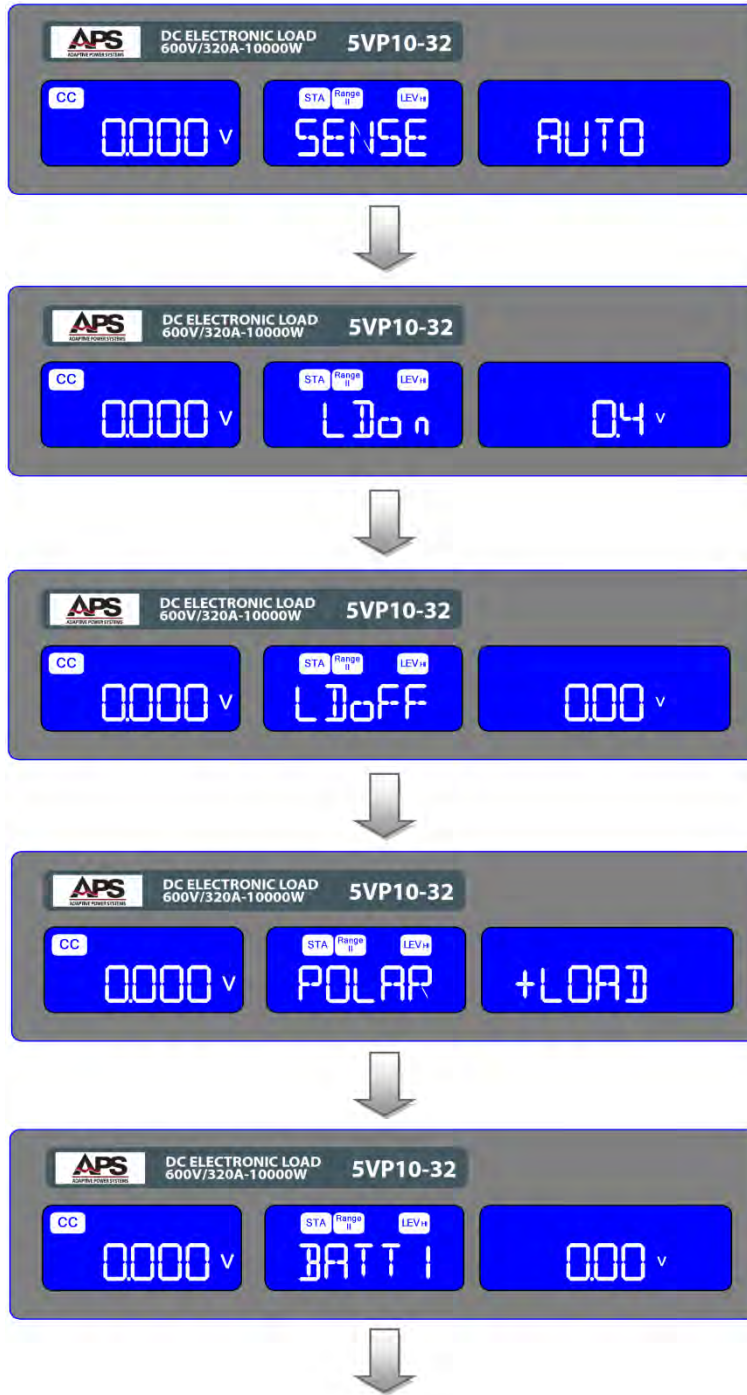

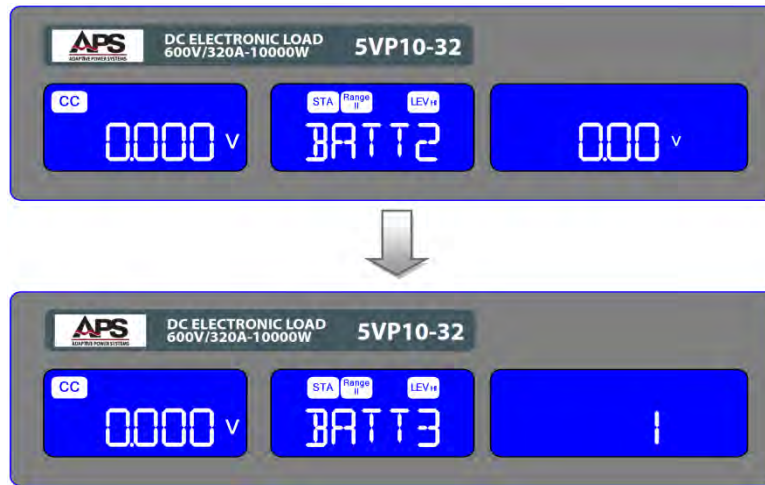
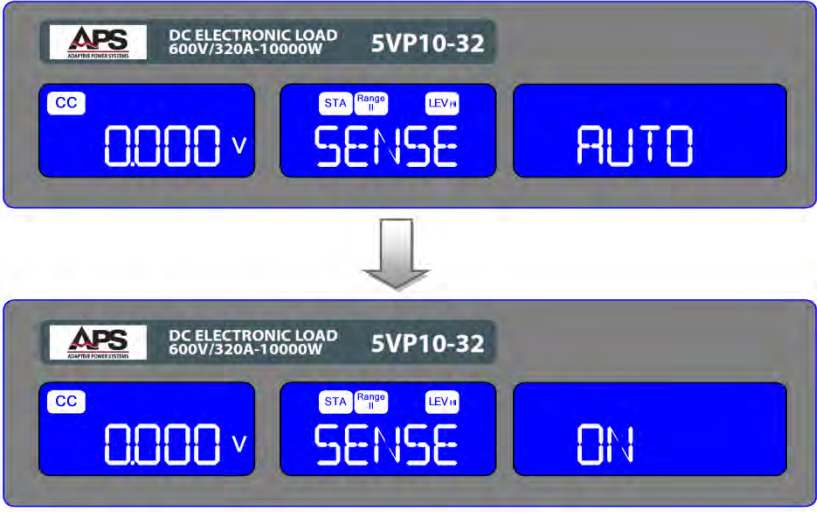
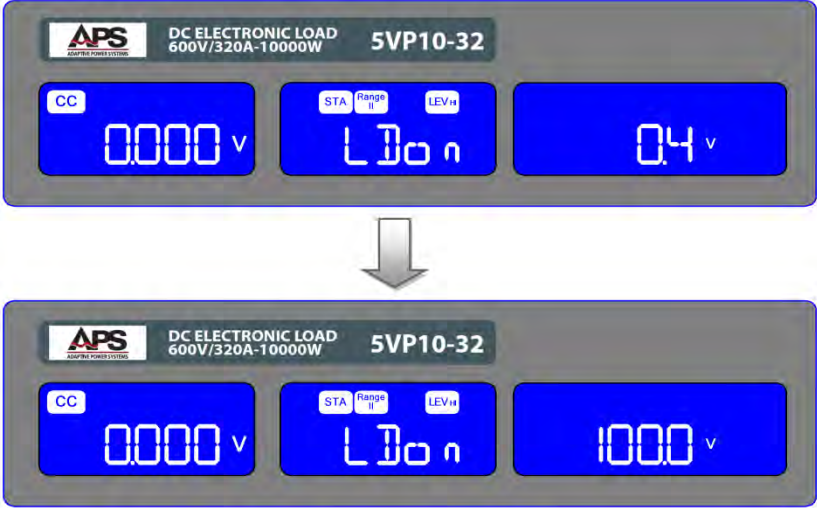

Figure 6-5: Configuration Menu Sequence

Each setting is described in the table below.

CONFIG	Description
<b>CONFIG</b>	Press the “Config” key once to enter the configuration setup screens. The “Config” key will illuminate. Pressing the “Config” key repeatedly will cycle through the configuration settings in the following sequence: “SENSE” → “Ldon” → “LDoff” → “POLAR” → “BATT1” → “BATT2” → “BATT3” → Exit. The first configuration setting screen for voltage sense will appear.

CONFIG	Description
	<p>On first press of the “Config” key, the voltage sense menu appears. The center LCD display shows “SENSE”, the right LCD shows either “AUTO” or “ON”. Use the up ▲ or down ▼ arrow keys to select between AUTO or OFF.</p> <p><b>Note:</b></p> <ul style="list-style-type: none"> <li>• If the V Sense mode is set to “AUTO” and the sense leads are connected to the EUT, the load cable voltage drop must be at least 700mV before the voltage measurement readout will be compensated for any voltage drop.</li> <li>• If the V Sense mode is set to “ON and the sense leads are connected to the EUT, the voltage measurement readout will always be compensated for any voltage drop.</li> </ul> <div style="text-align: center;">  </div>

CONFIG	Description
	<p> <b>LD on</b> Press the “Limit” key again to proceed to the load on voltage setting screen. The center LCD display shows “LDon”, the right LCD shows the set value in volts. Use the up ▲ or down ▼ arrow keys, shuttle or the numeric keypad to adjust the load on voltage setting. Available setting range is from 0.0V to 100.0 in 0.4V steps. If the sensed input voltage is larger than the LDon voltage setting, the load will turn on.         </p> <p> <b>Note:</b> LDon and LDoff setting are relevant only in CC, CR and CP mode of operation. They have no effect on CV mode where only the “Load” key turns the load on or off.         </p> <div style="text-align: center;">  </div>

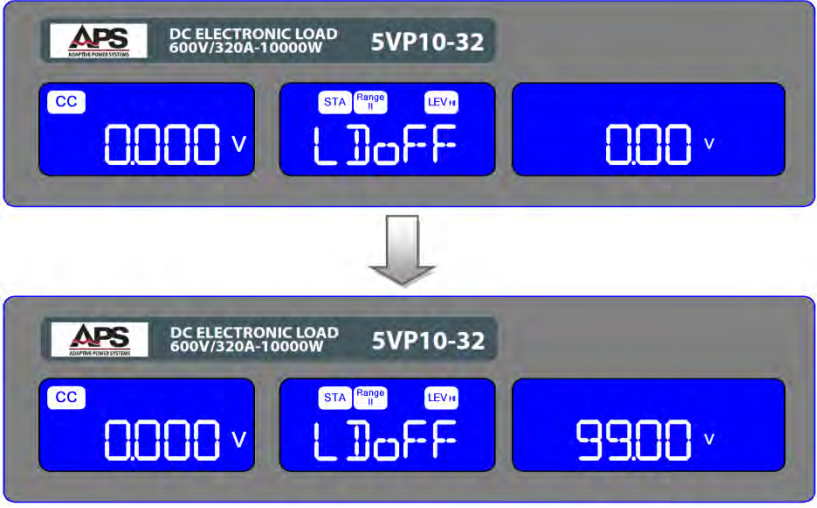
CONFIG	Description
	<p> <b>LD off</b> Press the “Limit” key again to proceed to the load off voltage setting screen. The center LCD display shows “LDoff”, the right LCD shows the set value in volts. Use the up ▲ or down ▼ arrow keys, shuttle or the numeric keypad to adjust the load off voltage setting. Available setting range is from 0.0V to 99.0 in 0.01V steps. If the sensed input voltage is less than the LDoff voltage setting, the load will turn off.         </p> <p> <b>Note:</b> LDon and LDoff setting are relevant only in CC, CR and CP mode of operation. They have no effect on CV mode where only the “Load” key turns the load on or off.         </p> <div style="text-align: center;">  </div>

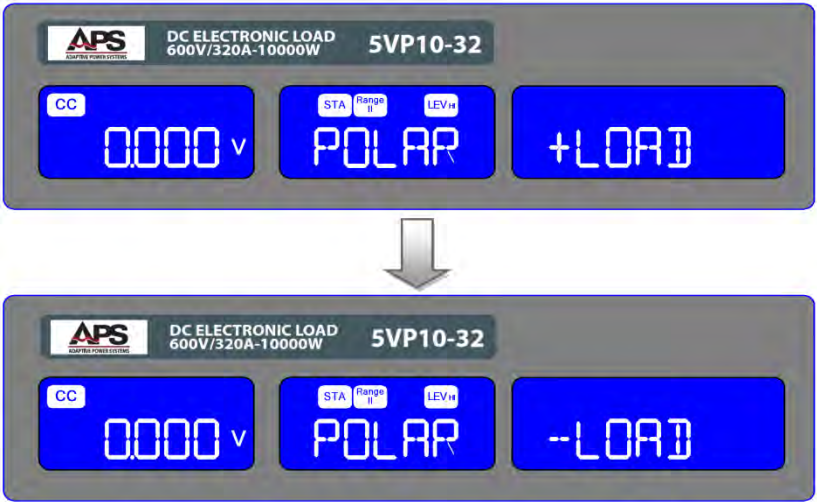
CONFIG	Description						
<b>POLAR</b>	<p>Press the “Limit” key again to proceed to the input polarity off voltage setting screen. The center LCD display shows “POLAR”, the right LCD shows either “+LOAD” or “-LOAD”. Use the up ▲ or down ▼ arrow keys to adjust the select the correct polarity setting. For –DC ground referenced EUT’s, use the +LOAD setting. For +DC ground referenced EUT’s, set the load to –LOAD polarity.</p>  <p><b>CAUTION:</b> If a reverse polarity situation occurs, the load will sink power even if the LOAD button is OFF. No current will be displayed on the load. Current up to the load’s maximum current rating will be tolerated in reverse polarity. However there is no OVP OCP and OPP protection under these conditions. It is strongly recommended that the load lines be fused if it is likely that the load could be subject to reverse polarity. These fuses should be fast acting and rated at the maximum current of the load +5%.</p>						
<b>BATT TESTS</b>	<p>The 5VP series features several built-in battery discharge test protocols. Three of these (BATT1 though BATT3) can be configured from the front panel using the “Config” key. BATT4 and BATT5 protocols require the use of a remote control interface. Refer to section 0, “Battery Discharge Protocols” on page 23 for more details on built-in battery discharge programs.</p>						
<b>No:</b>	<table border="1"> <tr> <td>1</td> <td>Discharges battery in CC mode using set current level till preset battery end voltage is reached and then load is turned off.</td> </tr> <tr> <td>2</td> <td>Discharges battery in CC mode using set current level till preset battery end voltage is reached and then switches to CV mode at set voltage.</td> </tr> <tr> <td>3</td> <td>Discharges battery in CC mode using set current level for the period of time specified. At end of test time, the load turns off and displays battery voltage.</td> </tr> </table>	1	Discharges battery in CC mode using set current level till preset battery end voltage is reached and then load is turned off.	2	Discharges battery in CC mode using set current level till preset battery end voltage is reached and then switches to CV mode at set voltage.	3	Discharges battery in CC mode using set current level for the period of time specified. At end of test time, the load turns off and displays battery voltage.
1	Discharges battery in CC mode using set current level till preset battery end voltage is reached and then load is turned off.						
2	Discharges battery in CC mode using set current level till preset battery end voltage is reached and then switches to CV mode at set voltage.						
3	Discharges battery in CC mode using set current level for the period of time specified. At end of test time, the load turns off and displays battery voltage.						

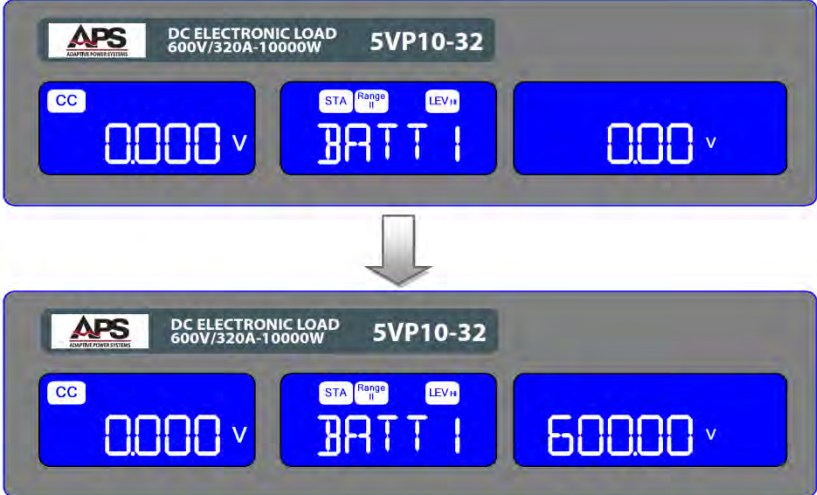
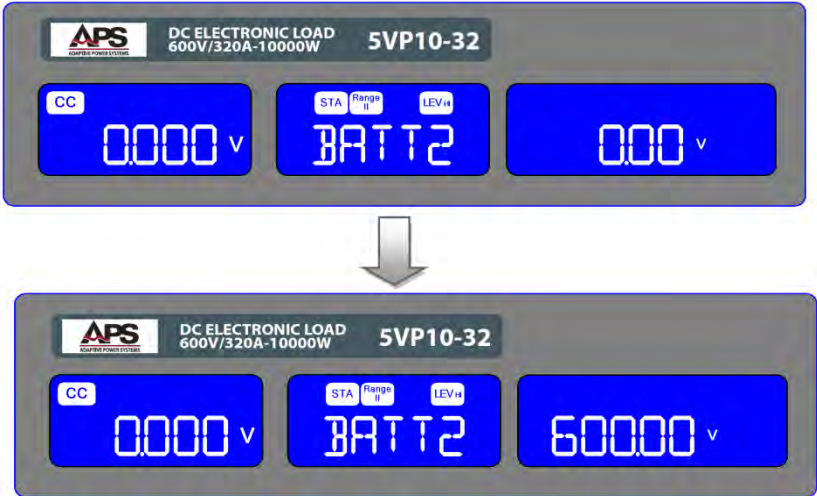
CONFIG	Description
	<p data-bbox="464 306 540 327"><b>BATT1</b></p> <p data-bbox="610 306 1403 457">Press the “Limit” key again to proceed to the first battery discharge test method. The center LCD display shows “BATT1”, the right LCD shows the battery discharge end-voltage setting in volts. Use the up ▲ or down ▼ arrow keys, shuttle or the numeric keypad to adjust the desired end voltage. Available range depends on the load model used.</p> <div data-bbox="613 470 1425 961">  </div>
	<p data-bbox="464 984 540 1005"><b>BATT2</b></p> <p data-bbox="610 984 1403 1136">Press the “Limit” key again to proceed to the first battery discharge test method. The center LCD display shows “BATT2”, the right LCD shows the battery discharge end-voltage setting in volts. Use the up ▲ or down ▼ arrow keys, shuttle or the numeric keypad to adjust the desired end voltage. Available range depends on the load model used.</p> <div data-bbox="613 1148 1425 1640">  </div>

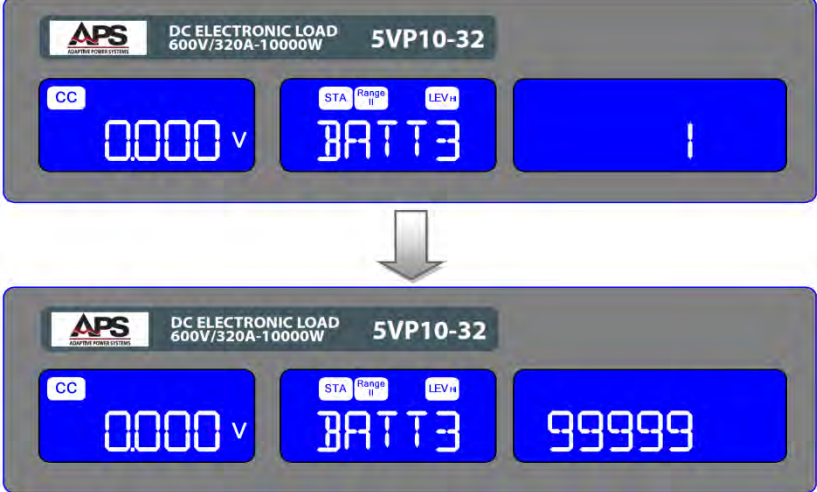
CONFIG	Description
	<p data-bbox="610 302 1414 491">Press the “Limit” key again to proceed to the first battery discharge test method. The center LCD display shows “BATT3”, the right LCD shows the battery discharge time in seconds. Use the up ▲ or down ▼ arrow keys, shuttle or the numeric keypad to adjust the desired discharge time. Available range is from 1 to 99999 secs (27:46:39 hh:mm:ss max.) in 1 sec steps.</p> <div data-bbox="613 506 1425 995" style="text-align: center;">  </div>
	<p data-bbox="610 1016 1195 1045">Press the “Config” key to exit the configuration mode.</p>

6.2.5.10 SEQ - AUTO SEQUENCE - EDIT MODE

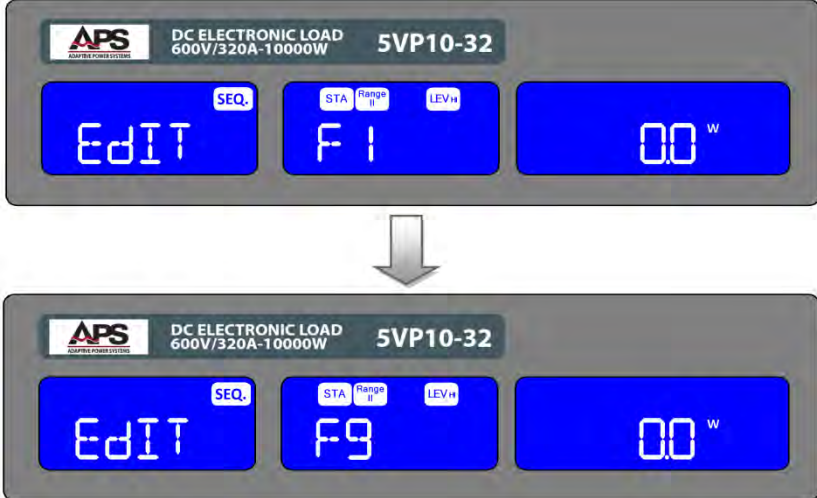
SEQ	Description
<p><b>SEQ</b></p>	<p>The AUTO SEQUENCE function supports 9 sequence programs (F1 through F9) that will sequence through up to 16 steps. Each step can recall any of the 150 memory STATE settings with a specific test duration dwell time between 0.1 sec and 9.9 sec in 100 msec resolution.</p> <p>The AUTO SEQUENCE function has an EDIT mode which allows programming sequences and a TEST mode which executes these programmed sequences. Flow charts for each mode are shown after the EDIT and TEST tables.</p>
<p><b>EDIT</b></p>	<p>Press the “Shift” key followed by the “SEQ” (Shift-Mode) key. This will enter the AUTO SEQUENCE mode and the <b>SEQ.</b> annunciator will be lit. Use the up ▲ or down ▼ arrow keys to select the EDIT mode. The left display will show “EdIT”, the center display will show “Fx” – where x can be one through 9 - and the right display shows a parameter setting. Use the “1” through “9” keys on the numeric keypad to select one of the nine available auto sequence programs F1 – F9.</p> <div style="text-align: center;">  <p>The diagram illustrates the front panel display of an APS 5VP10-32 DC Electronic Load. It features three main display areas: a left display showing 'EdIT', a center display showing 'F1' (which changes to 'F9' in the second image), and a right display showing '00 W'. Above the displays, there are several indicators: 'APS' logo, 'DC ELECTRONIC LOAD 600V/320A-10000W', '5VP10-32', and 'SEQ.' (which is lit). Below the center display, there are labels for 'STA', 'Range II', and 'LEV-H'. An arrow indicates the transition from F1 to F9.</p> </div>

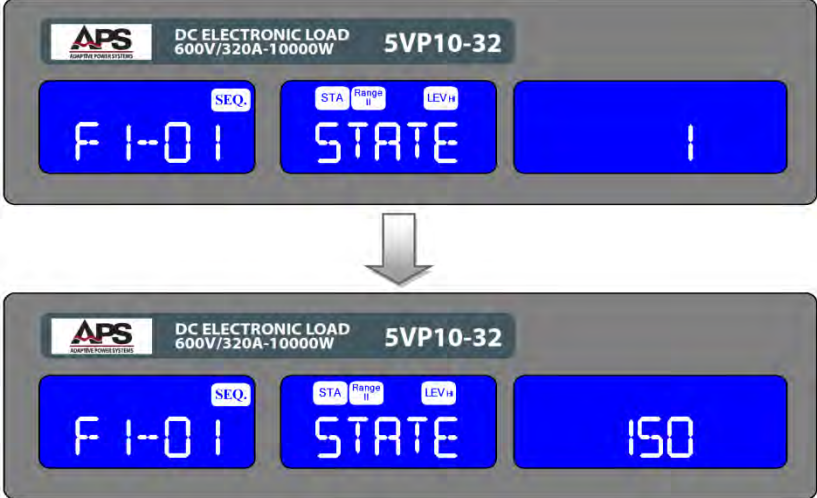
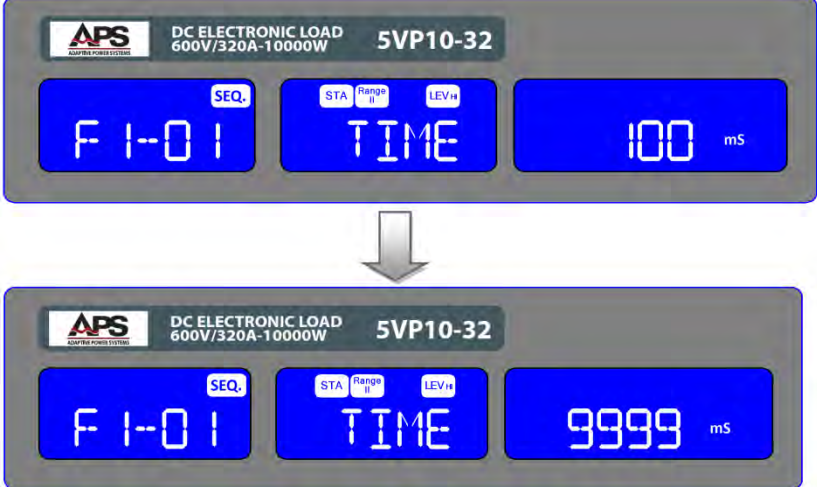
SEQ	Description
<p><b>EDIT-STATE</b></p>	<p>Press the “Enter” key to proceed in EDIT mode. The left display will show “F1-01” where F is the selected program number and 01 is the step number (01-16). The center display will show “STATE” and the right display shows a STATE number between 1 and 150.</p> <p>Use the up ▲ or down ▼ arrow keys, shuttle or the numeric keypad to select the STATE for this step. Available range is 1 through 150. Make sure a valid setup is stored in the STATE selected.</p> 
<p><b>EDIT-TIME</b></p>	<p>Press the “Enter” key to proceed in EDIT mode to the step time setting screen. The left display will still show the selected program step (“F1-01”), the center display will show “TIME” and the right display shows a value between 100 and 9999 msec.</p> <p>Use the up ▲ or down ▼ arrow keys, shuttle or the numeric keypad to select the desired dwell time for this step.</p> 

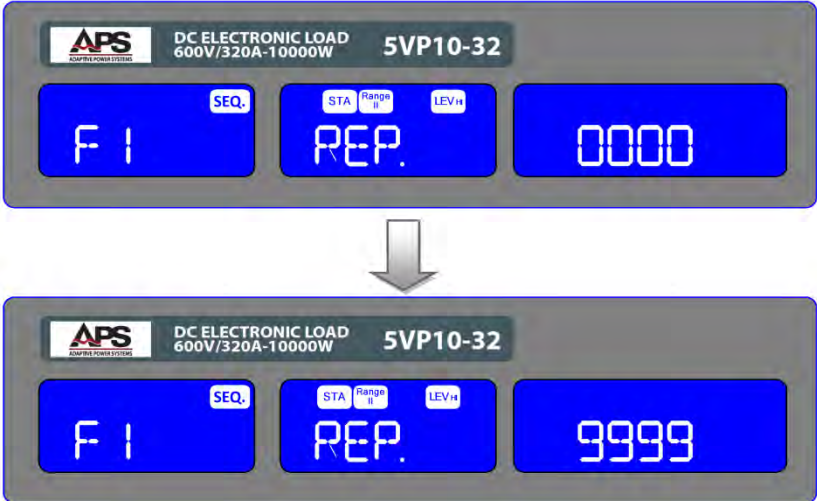
SEQ	Description
<p><b>EDIT-REPEAT</b></p>	<p>Press the “Enter” key to proceed in EDIT mode to the repeat setting screen. The left display will still show the selected program step (“F1-01”), the center display will show “REP.” and the right display shows a value between 0000 and 9999.</p> <p>Use the up ▲ or down ▼ arrow keys, shuttle or the numeric keypad to select the desired repetitions for this step.</p> <div style="text-align: center;">  </div>
<p><b>Exit</b></p>	<p>To save the AUTO SEQUENCE settings, press the “Enter” key when done. This will also exit the EDIT the mode.</p>



### 6.2.5.1 SEQ - AUTO SEQUENCE – TEST MODE

Once one or more auto sequence programs have been set up, they can be executed in AUTO SEQUENCE TEST mode using the steps outlined in the table below.

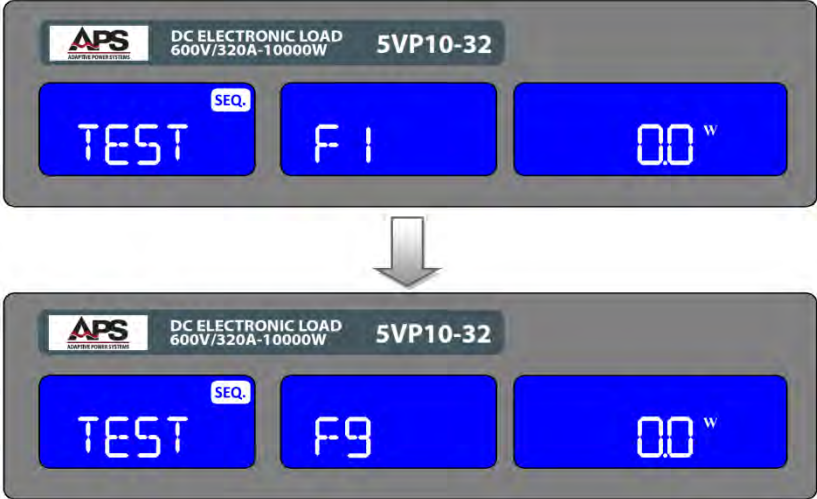
SEQ	Description
<b>SEQ</b>	To execute an AUTO SEQUENCE, proceed to the TEST mode.
<b>EDIT</b>	<p>Press the “Shift” key followed by the “SEQ” (Shift-Mode) key. This will enter the AUTO SEQUENCE mode and the <b>SEQ.</b> annunciator will be lit. Use the up ▲ or down ▼ arrow keys to select the TEST mode. The left display will show “TEST”, the center display will show “Fx” – where x can be one through 9 - and the right display shows a parameter setting. Use the “1” through “9” keys on the numeric keypad to select one of the nine available auto sequence programs F1 – F9.</p> 
<b>EDIT-STATE</b>	Press the “Enter” key to proceed in TEST mode. The left display will show the active test step as “SXX:XX”. The center display will show a flashing “NG” indication at the end of each test step. At this point, the user can press the “Enter” to proceed to the next step or press the “Exit” (Shift – STA/DYN) key to abort the test sequence.
<b>PASS RESULT</b>	If all steps complete with PASS results, the LCD display will show “PASS” and the buzzer will sound if enabled (See section 6.2.4, “System Keys and Numeric Entry Keys” on page 88) to indicate the test sequence has completed.
<b>FAIL RESULT</b>	If any one step had a FAIL result, the LCD display will show “FAIL” and the buzzer will sound once if enabled. (See section 6.2.4, “System Keys and Numeric Entry Keys” on page 88) to indicate the test sequence has completed and again a second time to indicate the test result is FAIL.
<b>Exit</b>	When the AUTO SEQUENCE has completed, the user can exit the AUTO SEQUENCE mode by pressing the “Enter” key when.

6.2.5.2 SEQ - AUTO SEQUENCE - Test Example

Screen below show the test executions progress from step 1 through 16.

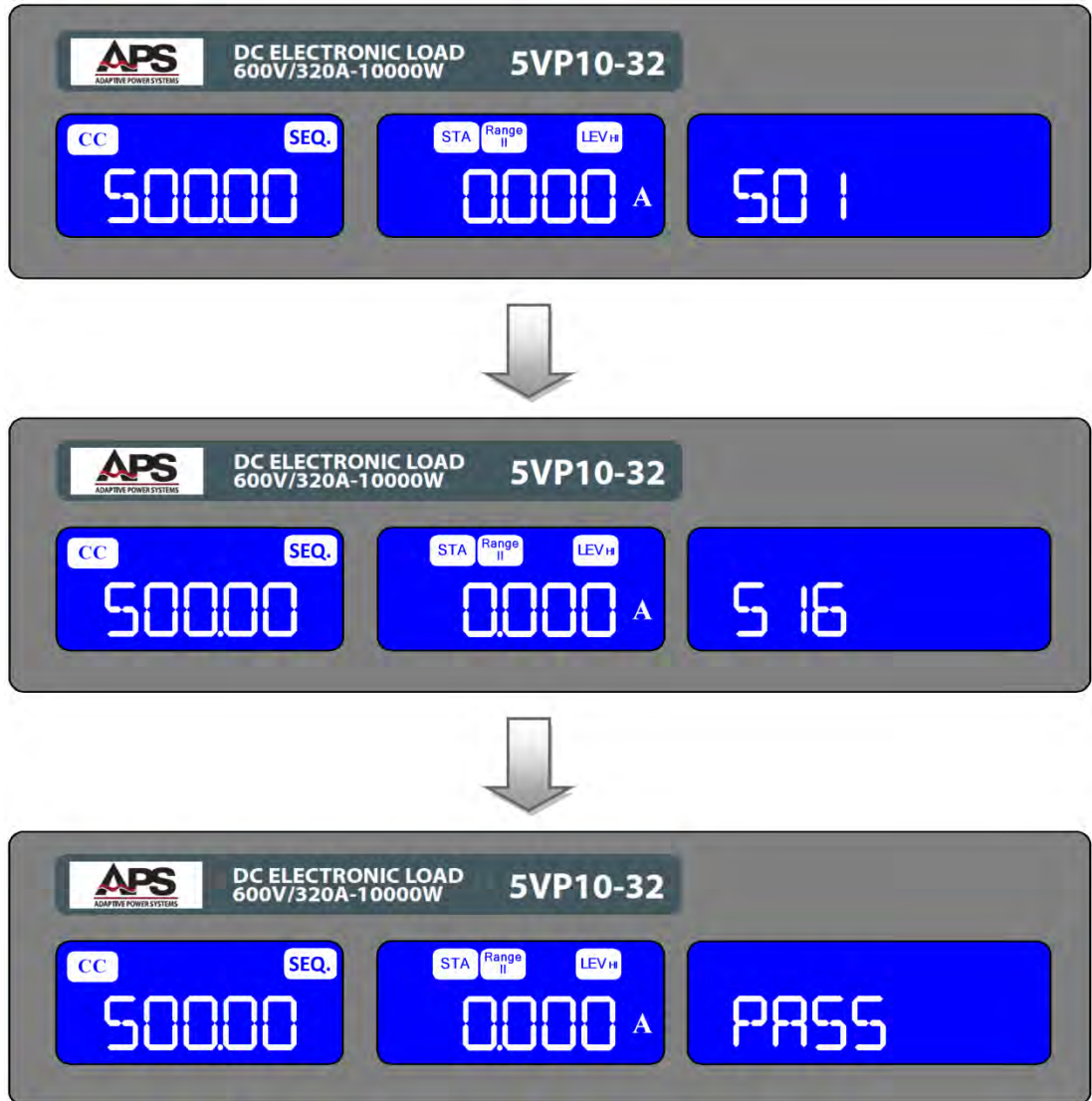

6.2.5.3 SEQ - AUTO SEQUENCE – TEST mode flow chart

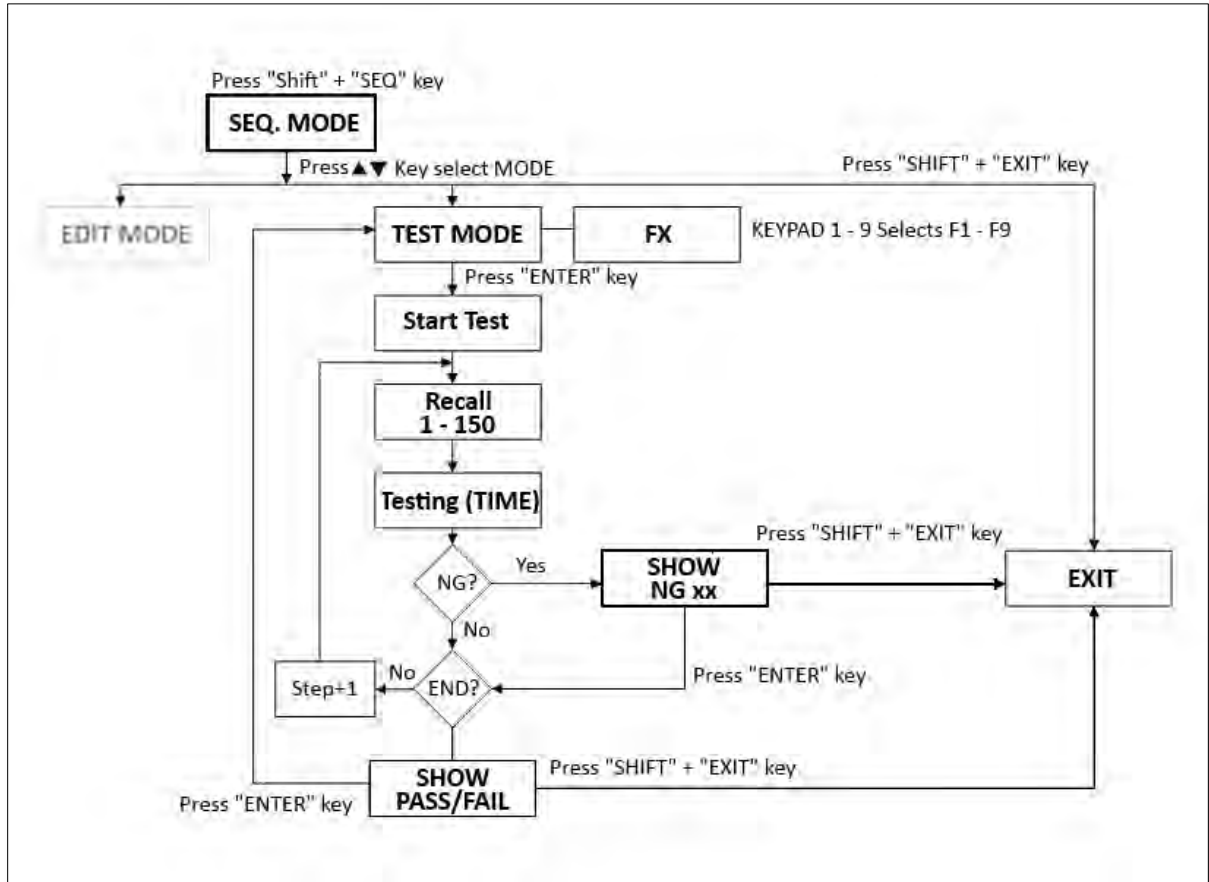

Figure 6-7: AUTO SEQUENCE TEST Mode Flow Chart

### 6.2.6 Test Setting Keys

The Test Setting area of the keyboard contains four keys; one to start the selected built-in test and the rest to configure each of the three available test setups. From top to bottom they are:





Test Setting	Description
<b>Start/Stop</b>	Starts selected test mode. If test is already in progress, the same key can be used to abort the test.
<b>Short</b>	Enter setup for SHORT circuit test
<b>OPP</b>	Enter setup for over power protection test
<b>OCP</b>	Enter setup for over current protection test

Setup and use of each test mode is describes in this section of the manual. Examples for each available test mode can be found in section 12, “Short Circuit, OPP and OCP Test Examples” on page 211.

#### 6.2.6.1 Short Key and Indicator

The “Short” key allows the parameters of a SHORT circuit test to be entered. The SHORT test will attempt to sink current up to the 5VP series load model’s maximum current in order to check the power supply’s protection functions and output behavior. The short circuit test time can be adjusted and threshold values for high and low voltage limits set.

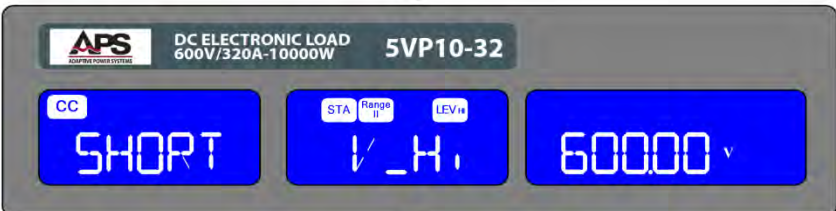
SHORT	Description
<b>SHORT</b>	SHORT Test
<b>Execute</b>	<p>Press the “<b>Short</b>” key to enter the SHORT test mode. The “<b>Short</b>” key will illuminate to indicate SHORT circuit test mode is selected. The three LCD displays will show “SHORT”, “PRESS” and “START”.</p> <p>Each time the “<b>Short</b>” key is pressed, it moves to the next available setup screen. Setups are shown in the following sequence:            “SHORT PRESS START” → “SHORT TIME CONTI” → “SHORT V_Hi” → “SHORT V_Lo” → Exit.</p>

SHORT	Description
	 <p>DC ELECTRONIC LOAD 600V/320A-10000W 5VP10-32</p> <p>CC: SHORT    STA Range II LEV II: PRESS    START</p>
	 <p>DC ELECTRONIC LOAD 600V/320A-10000W 5VP10-32</p> <p>CC: SHORT    STA Range II LEV II: TIME    CONTI</p>
	 <p>DC ELECTRONIC LOAD 600V/320A-10000W 5VP10-32</p> <p>CC: SHORT    STA Range II LEV II: V_H    60000 V</p>
	 <p>DC ELECTRONIC LOAD 600V/320A-10000W 5VP10-32</p> <p>CC: SHORT    STA Range II LEV II: V_Lo    000 V</p>
	 <p>DC ELECTRONIC LOAD 600V/320A-10000W 5VP10-32</p> <p>CC: 50000 V    STA Range II LEV II: 0000 A    00 W</p>

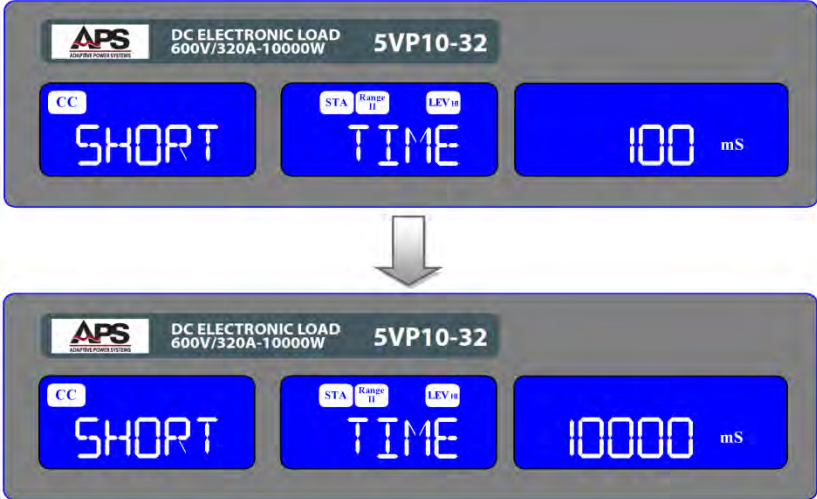
SHORT	Description
<p><b>Test Time</b></p>	<p>Press the <b>“Short”</b> key to enter the short time setting screen. The left LCD will display <b>“SHORT”</b>, the center LCD will display <b>“TIME”</b> and the right LCD will either show <b>“CONTI”</b> or a value in msec.</p>  <p>“CONTI” means continuous which will apply the short condition until the user presses the <b>“Start/Stop”</b> to abort the test.</p>
	<p>To set a short test time, rotate the shuttle clock wise until the desired time is shown on the right hand side LCD. The available setting range is from 100 msec to 10000 msec (10 seconds) in 100 msec steps.</p> 

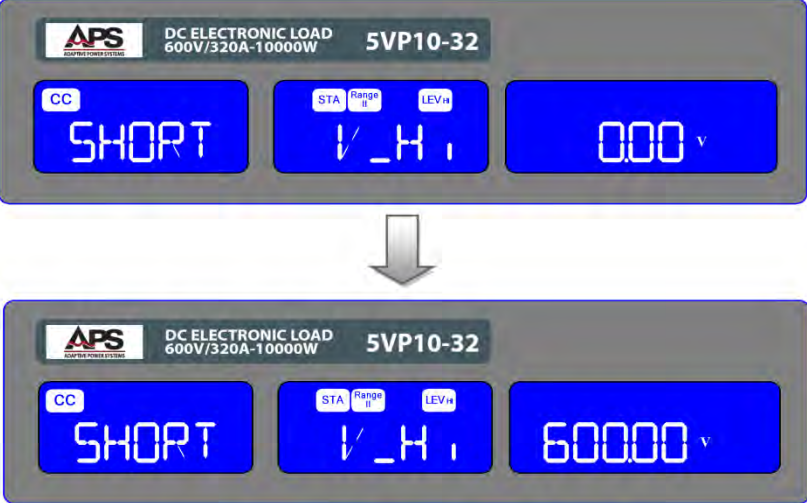
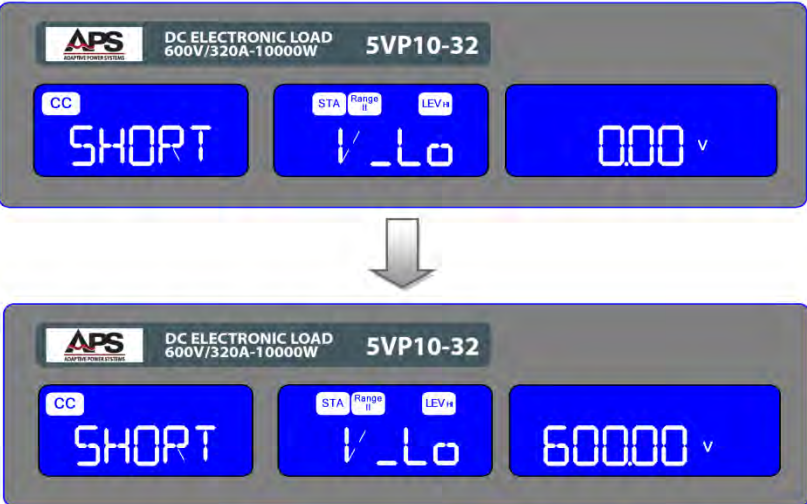
SHORT	Description
	<p><b>V_Hi</b></p> <p>V_Hi is the upper voltage limit that is allowed during the short test. Press the “Short” key once to proceed to the “V_Hi setting screen. The left LCD will display “SHORT”, the center LCD will display “V_Hi” and the right LCD will display the voltage limit value in volts.</p> <p>Use the up ▲ or down ▼ arrow keys, shuttle or the numeric keypad to select the desired V_Hi level for this test. Available range depends on the load model.</p> 
	<p><b>V_Lo</b></p> <p>V_Lo is the lower voltage limit that is allowed during the short test. Press the “Short” key once to proceed to the “V_Lo setting screen. The left LCD will display “SHORT”, the center LCD will display “V_Lo” and the right LCD will display the voltage limit value in volts.</p> <p>Use the up ▲ or down ▼ arrow keys, shuttle or the numeric keypad to select the desired V_Lo level for this test. Available range depends on the load model.</p> 

SHORT	Description
	<p><b>Execute</b> Once the test parameters have been entered the test is started by pressing the red <b>“Start/Stop”</b> button while the <b>“SHORT PRESS START”</b> text is displayed. During the test the right LCD will show run and the actual short current will be displayed on the center LCD.</p>

### **Test Results**

The message **“PASS END”** will be displayed at the end of the test if the measured voltage during the short test remains within the V\_Hi and V\_Lo limit boundaries.





The message **“PASS FAIL”** will be displayed at the end of the test if the measured voltage during the short test falls outside the V\_Hi and V\_Lo limit boundaries at any time during the test run. In this case, the **“NG”** indication will also be on.

### 6.2.6.2 OPP Key and Indicator

The OPP key allows the parameters of an Over Power Protection test to be entered. The OPP test will ramp up the load power in steps to verify the equipment under test's (EUT) over power protection and behavior. A voltage threshold level can be set for this test. If the voltage measured during the test drops below this threshold value, the test will fail and the load will display an OPP ERROR. Also, a power level threshold (PSTOP) can be set. If the measured power reaches the PSTOP threshold value, the test will be discontinued and an OPP ERROR message will be displayed.

Instructions on how to set up an OPP test are shown in the table below.

OPP	Description
<b>OPP</b>	Over Power Protection Test
	<p><b>Execute</b> Press the "<b>OPP</b>" key to enter the OPP test mode. The "<b>OPP</b>" key will illuminate to indicate OPP circuit test mode is selected. The three LCD displays will show "OPP", "PRESS" and "START".</p> <p>Each time the "<b>OPP</b>" key is pressed, it moves to the next available setup screen. Setups are shown in the following sequence:            "OPP PRESS START" → "OPP PSTAR" → "OPP PSTEP" → "OPP PSTOP" → "OPP VTH" → Exit.</p>

OPP	Description
	 <p>DC ELECTRONIC LOAD 5VP10-32 600V/320A-10000W</p> <p>CC: OCP    STA Range II LEV:II    PRESS    START</p>
	 <p>DC ELECTRONIC LOAD 5VP10-32 600V/320A-10000W</p> <p>CC: OCP    STA Range II LEV:II    ISTAR    0.00 A</p>
	 <p>DC ELECTRONIC LOAD 5VP10-32 600V/320A-10000W</p> <p>CC: OCP    STA Range II LEV:II    ISTEP    0.01 A</p>
	 <p>DC ELECTRONIC LOAD 5VP10-32 600V/320A-10000W</p> <p>CC: OCP    STA Range II LEV:II    ISTOP    32000 A</p>
	 <p>DC ELECTRONIC LOAD 5VP10-32 600V/320A-10000W</p> <p>CC: OCP    STA Range II LEV:II    V/TH    60.00 V</p>

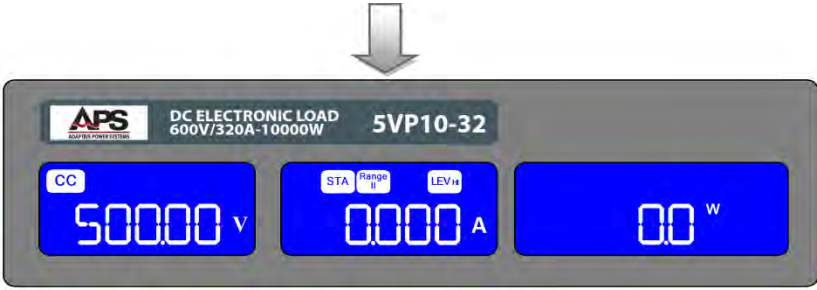
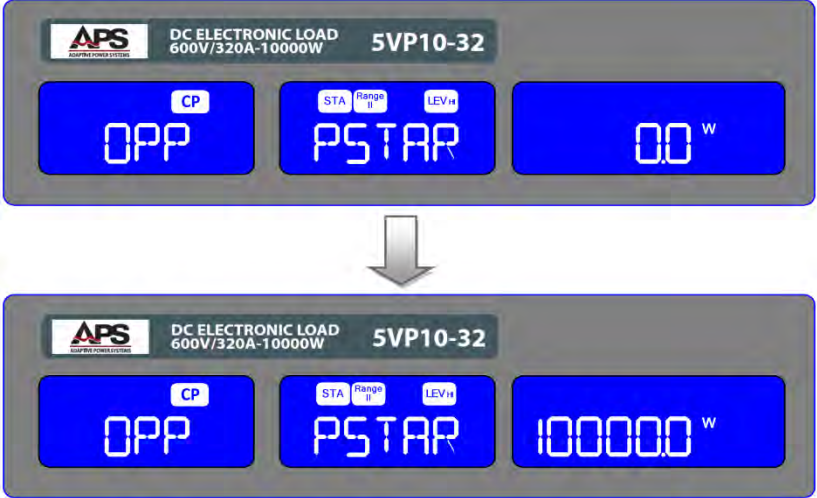
OPP	Description
	
	<p><b>PSTAR</b></p> <p>Press the “<b>OPP</b>” key again to proceed to the PSTAR setting screen. The left LCD will display “<b>OPP</b>”, the center LCD will display “<b>PSTAR</b>” and the right LCD will display the power setting in watts.</p> <p>Use the up ▲ or down ▼ arrow keys, shuttle or the numeric keypad to select the desired start power level for this test. Available range starts at 0.00W and maximum value depends on the load model.</p> 

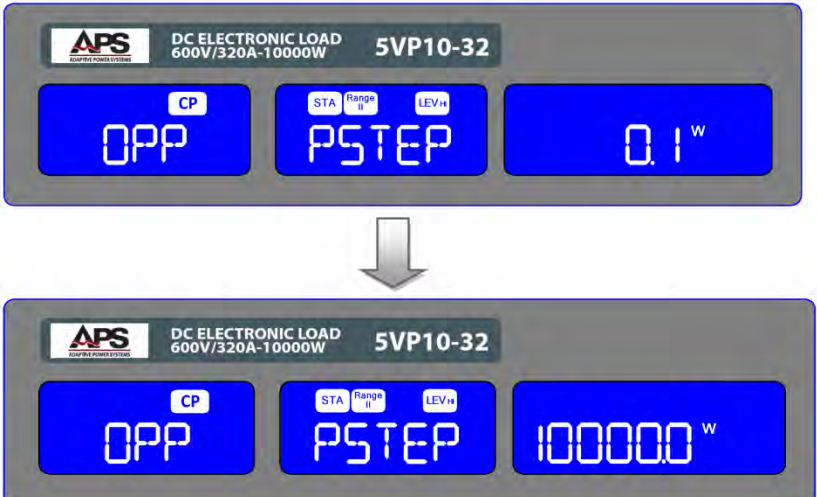
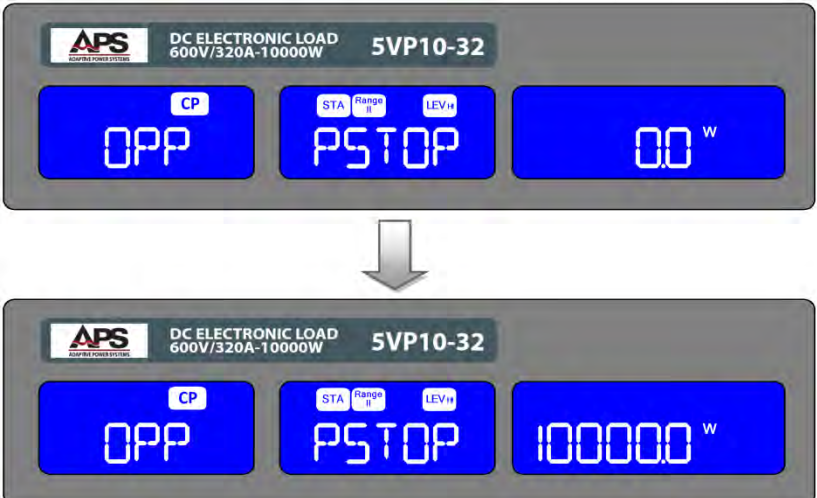
OPP	Description
	<p><b>PSTEP</b></p> <p>Press the “<b>OPP</b>” key again to proceed to the PSTEP setting screen. The left LCD will display “<b>OPP</b>”, the center LCD will display “<b>PSTEP</b>” and the right LCD will display the power step value setting in watts.</p> <p>Use the up ▲ or down ▼ arrow keys, shuttle or the numeric keypad to select the desired power increment level for each test step. Available range starts at 0.01W and maximum value depends on the load model.</p> 
	<p><b>PSTOP</b></p> <p>Press the “<b>OPP</b>” key again to proceed to the PSTOP setting screen. The left LCD will display “<b>OPP</b>”, the center LCD will display “<b>PSTOP</b>” and the right LCD will display the power setting in watts.</p> <p>Use the up ▲ or down ▼ arrow keys, shuttle or the numeric keypad to select the desired stop power level for this test. Available range starts at 0.00W and maximum value depends on the load model.</p> 

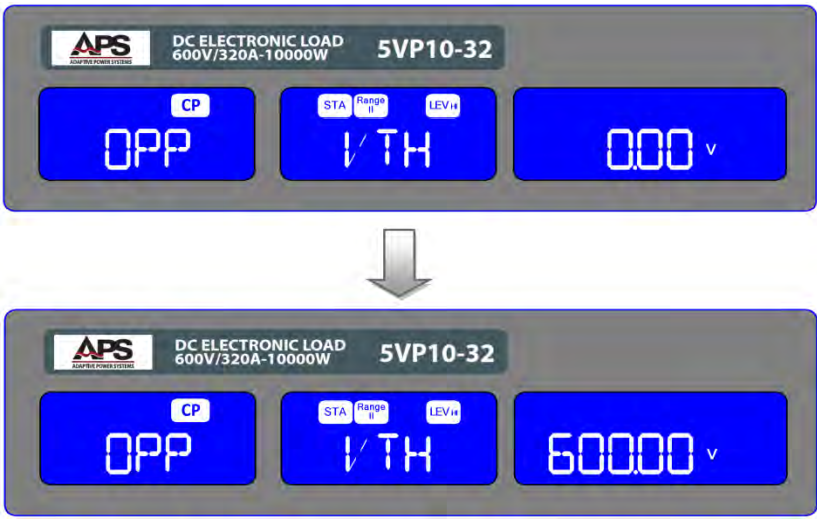
OPP	Description
	<p><b>VTH</b></p> <p>VTH is the lowest voltage that is allowed during the OPP test. Press the “<b>OPP</b>” key once to proceed to the “VTH” setting screen. The left LCD will display “OPP”, the center LCD will display “VTH” and the right LCD will display the voltage limit value in volts.</p> <p>Use the up ▲ or down ▼ arrow keys, shuttle or the numeric keypad to select the desired VTH level for this test. Available range depends on the load model.</p> 
	<p><b>Execute</b></p> <p>Once the test parameters have been entered the test is started by pressing the red “<b>Start/Stop</b>” button while the “OPP PRESS START” text is displayed. During the test the center LCD will show run and the actual power will be displayed on the right hand side LCD..</p>

### Test Results

The message “**OPP ERROR**” will be displayed at the end of the test if one or both of the following conditions occurred:

1. The measured voltage during the short test fails below the VTH threshold voltage.
2. The power delivered by the EUT reaches the PSTOP setting value.

In this case, the “**NG**” indication will also be on.





The message “**PASS**” will be displayed if the measured voltage during the OPP test remains above the VTH voltage threshold setting and the power delivered by the EUT never reaches the PSTOP value.



### 6.2.6.3 OCP Key and Indicator



The OCP key allows the parameters of an Over Current Protection test to be entered. The OCP test will ramp up the load current in steps to verify the equipment under test's (EUT) over current protection and behavior. A voltage threshold level can be set for this test. If the voltage measured during the test drops below this threshold value, the test will fail and the load will display an OCP ERROR. Also, a current threshold (ISTOP) can be set. If the measured current reaches the ISTOP threshold value, the test will be discontinued and an OCP ERROR message will be displayed.

Instructions on how to set up an OCP test are shown in the table below.

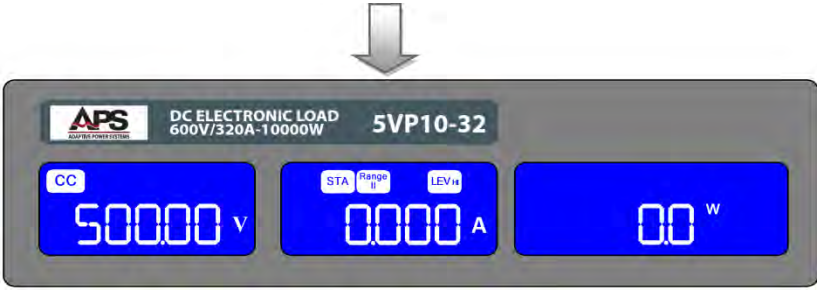
OCP	Description	
<b>OCP</b>	Over Current Protection Test	
	<b>Execute</b>	Press the " <b>OCP</b> " key to enter the OCP test mode. The " <b>OCP</b> " key will illuminate to indicate OCP circuit test mode is selected. The three LCD displays will show "OCP", "PRESS" and "START".  Each time the " <b>OCP</b> " key is pressed, it moves to the next available setup screen. Setups are shown in the following sequence: "OCP PRESS START" → "OCP ISTAR" → "OCP ISTEP" → "OCP ISTOP" → "OCP VTH" → Exit.

OCP	Description
	 <p>DC ELECTRONIC LOAD 5VP10-32 600V/320A-10000W</p> <p>CC: OCP    STA Range II LEV: II    PRESS    START</p>
	 <p>DC ELECTRONIC LOAD 5VP10-32 600V/320A-10000W</p> <p>CC: OCP    STA Range II LEV: II    ISTAR    000 A</p>
	 <p>DC ELECTRONIC LOAD 5VP10-32 600V/320A-10000W</p> <p>CC: OCP    STA Range II LEV: II    ISTEP    00 I A</p>
	 <p>DC ELECTRONIC LOAD 5VP10-32 600V/320A-10000W</p> <p>CC: OCP    STA Range II LEV: II    ISTOP    32000 A</p>
	 <p>DC ELECTRONIC LOAD 5VP10-32 600V/320A-10000W</p> <p>CC: OCP    STA Range II LEV: II    VTH    6000 V</p>

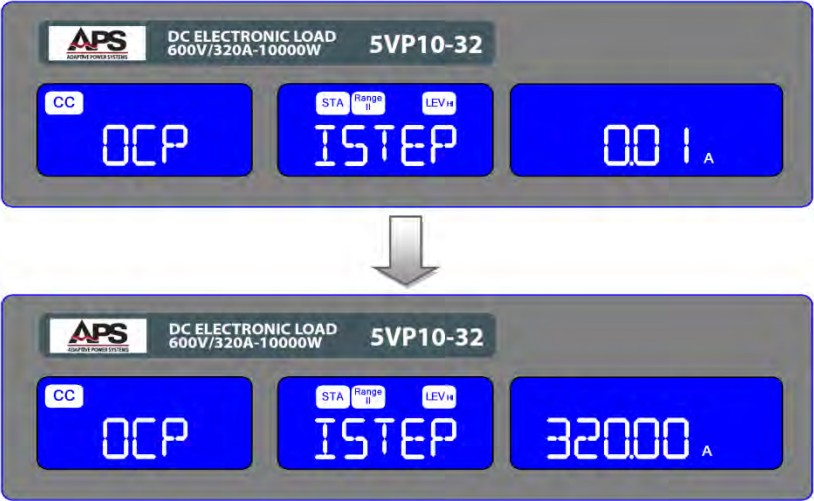
OCP	Description
	 <p>The screenshot shows the front panel of an APS DC Electronic Load (model 5VP10-32). The display is divided into three sections: a left LCD showing '50000 V', a center LCD showing '0000 A', and a right LCD showing '00 W'. Above the displays, the text 'DC ELECTRONIC LOAD 600V/320A-10000W' and '5VP10-32' is visible. A downward arrow points to this screenshot from the top of the table.</p>
	<p><b>ISTAR</b></p> <p>Press the “OCP” key again to proceed to the ISTAR setting screen. The left LCD will display “OCP”, the center LCD will display “ISTAR” and the right LCD will display the current setting in amps.</p> <p>Use the up ▲ or down ▼ arrow keys, shuttle or the numeric keypad to select the desired start current level for this test. Available range starts at 0.000A and maximum value depends on the load model.</p>  <p>The first screenshot shows the front panel with the left LCD displaying 'OCP', the center LCD displaying 'ISTAR', and the right LCD displaying '000 A'. A downward arrow points to the second screenshot below it. The second screenshot shows the same front panel, but the right LCD now displays '32000 A'.</p>

OCP	Description
	<p><b>ISTEP</b></p> <p>Press the “OCP” key again to proceed to the ISTEP setting screen. The left LCD will display “OCP”, the center LCD will display “ISTEP” and the right LCD will display the step current value setting in amps.</p> <p>Use the up ▲ or down ▼ arrow keys, shuttle or the numeric keypad to select the desired current increment level for each test step. Available range starts at 0.01A and maximum value depends on the load model.</p> 
	<p><b>ISTOP</b></p> <p>Press the “OCP” key again to proceed to the ISTOP setting screen. The left LCD will display “OCP”, the center LCD will display “ISTOP” and the right LCD will display the current setting in amps.</p> <p>Use the up ▲ or down ▼ arrow keys, shuttle or the numeric keypad to select the desired stop current level for this test. Available range starts at 0.000A and maximum value depends on the load model.</p> 

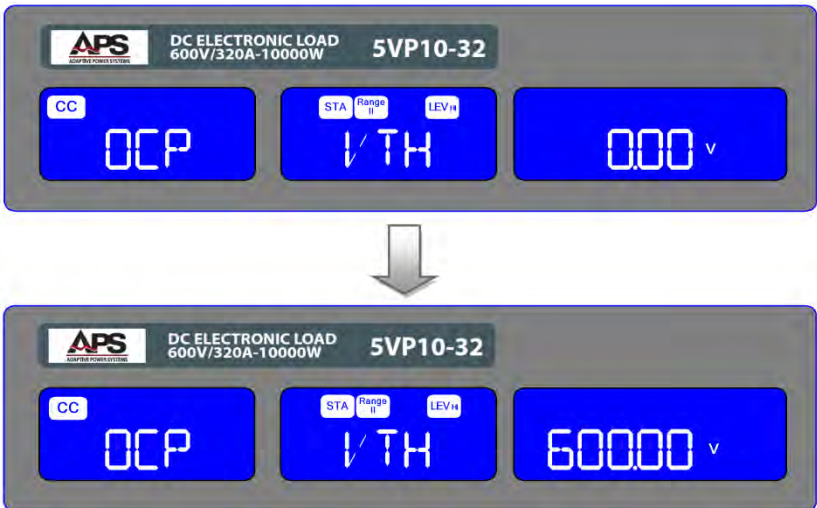
OCP	Description
	<p><b>VTH</b></p> <p>VTH is the lowest voltage that is allowed during the OCP test. Press the “OCP” key once to proceed to the “VTH” setting screen. The left LCD will display “OCP”, the center LCD will display “VTH” and the right LCD will display the voltage limit value in volts.</p> <p>Use the up ▲ or down ▼ arrow keys, shuttle or the numeric keypad to select the desired VTH level for this test. Available range depends on the load model.</p> 
	<p><b>Execute</b></p> <p>Once the test parameters have been entered the test is started by pressing the red “Start/Stop” button while the “OCP PRESS START” text is displayed. During the test the center LCD will show run and the actual current will be displayed on the right hand side LCD..</p>

**Test Results**

The message “OCP ERROR” will be displayed at the end of the test if one or both of the following conditions occurred:

3. The measured voltage during the short test fails below the VTH threshold voltage.
4. The current drawn by the EUT reaches the ISTOP setting value.

In this case, the “NG” indication will also be on.

The message “PASS” will be displayed if the measured voltage during the OCP test remains above the VTH voltage threshold setting and the current never reaches the ISTOP value.

### 6.2.7 Data Entry – Shuttle, Cursor Keys and Keypad

The shuttle and cursor keys may be used to change parameter settings in any of the setup screens. These compliment the numeric keypad for that entry. This shuttle in particular is useful for slewing through a limited range of values or selections. The cursor keys can be used to increment or decrement a setting value using the minimum step size.

#### 6.2.7.1 Shuttle Knob / Rotary Knob

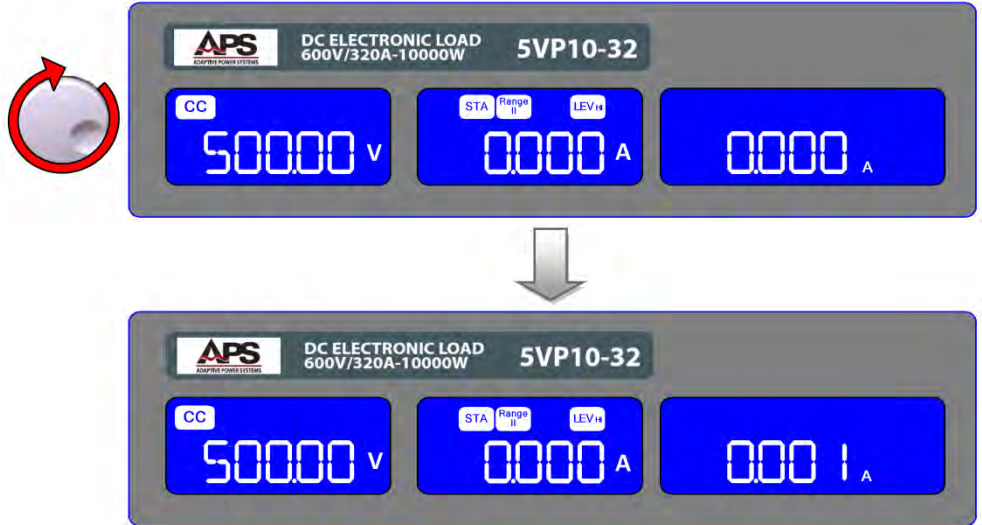
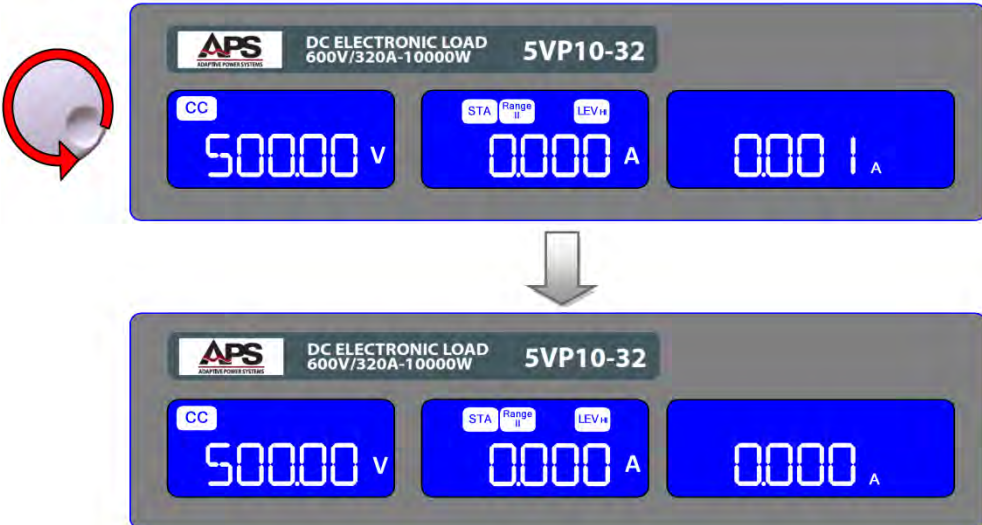
Shuttle	Operation
<b>Right Turn</b>	Right turn shuttle: Adjust value clockwise to increase set value 
<b>Left Turn</b>	Left turn shuttle: Adjust value counter clockwise to decrease set value 
<p> <b>Note 1:</b> In constant resistance (CR) mode, the UP key and clockwise operation of the shuttle reduces the resistance setting.  <b>Note 2:</b> In constant resistance (CR) mode, the DOWN key and counter clockwise operation of the shuttle increases the resistance setting.         </p>	

6.2.7.2 Cursor Up/Down Keys

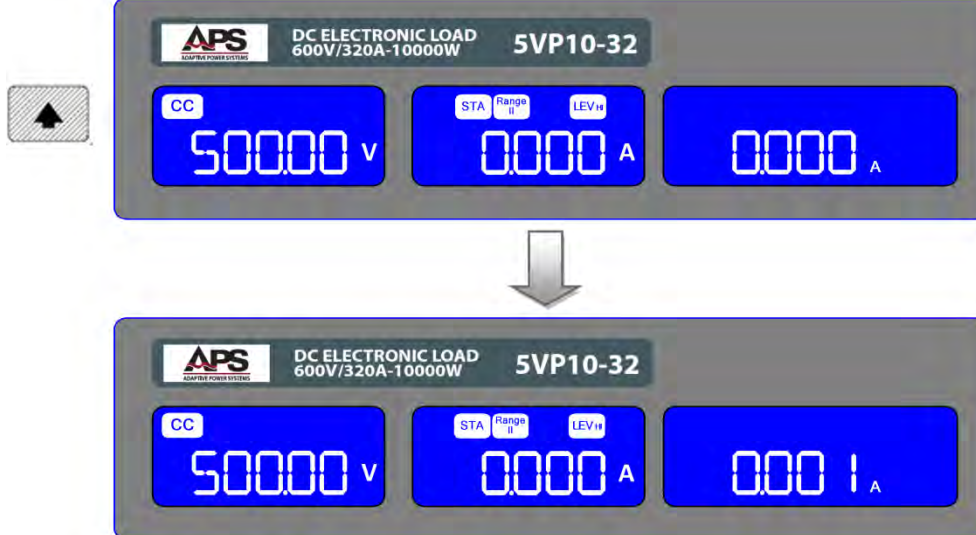
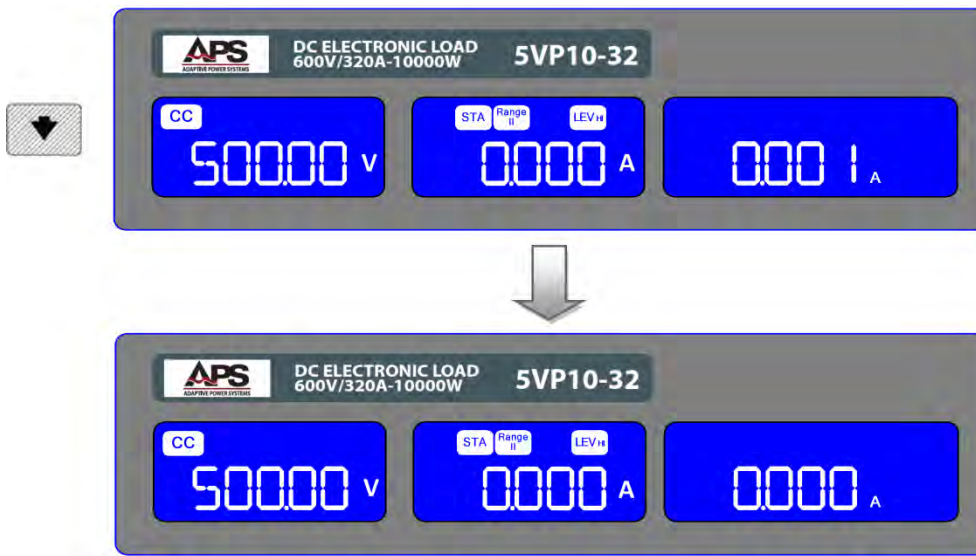
Cursor	Operation
UP	<p>Press Cursor UP key (▲) to increase set value</p> 
DOWN	<p>Press Cursor DOWN key (▼) to decrease set value</p> 
<p><b>Note 1:</b> In constant resistance (CR) mode, the UP key and clockwise operation of the shuttle reduces the resistance setting.</p> <p><b>Note 2:</b> In constant resistance (CR) mode, the DOWN key and counter clockwise operation of the shuttle increases the resistance setting.</p>	

6.2.7.3 Numeric Keypad

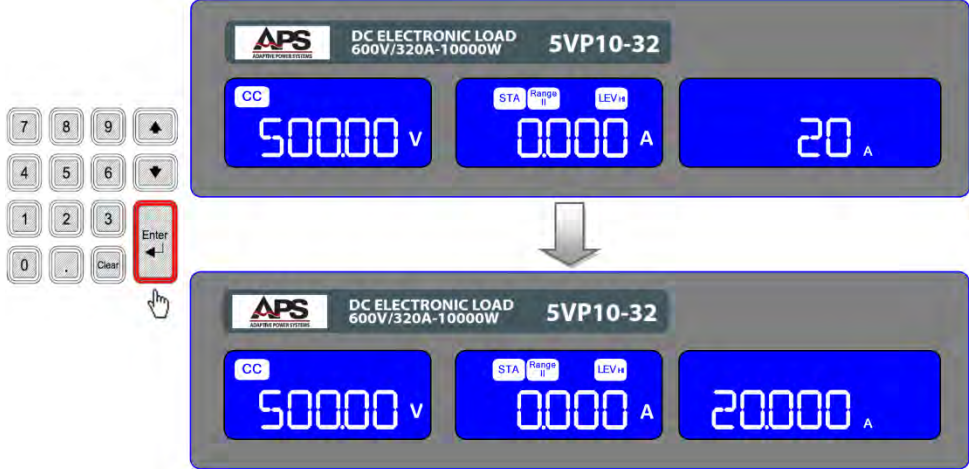
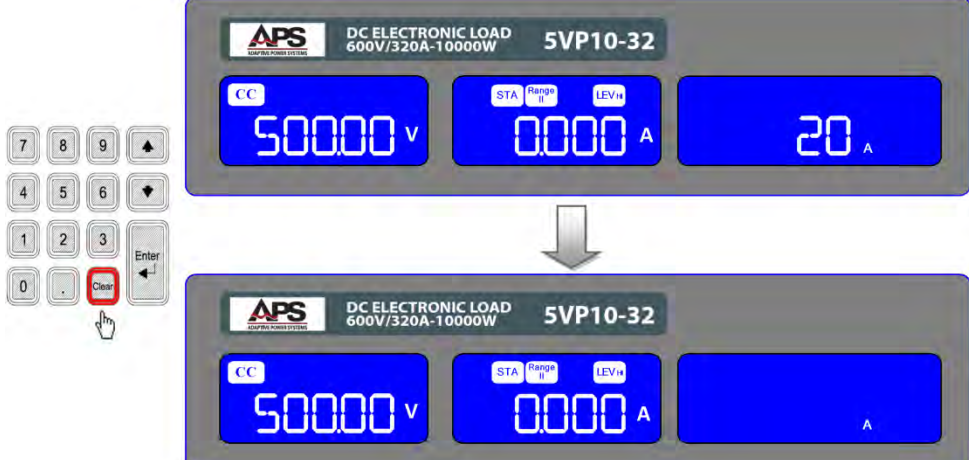
Key	Operation
<p><b>Enter</b></p>	<p>Press the “Enter” key after entering a new value to confirm setting.</p> 
<p><b>Clear</b></p>	<p>Press the “Clear” key to clear data value.</p> 

### 6.3 Go/NoGo LIMIT Testing

The 5VP Series loads have built in Go/NoGo test capability as part of their measurement systems. This allows abnormal conditions to be detected automatically so an EUT can be passed or rejected quickly in a production test environment.

#### 6.3.1 Limits

The Go/NoGo is based on comparing measurement data against user provided upper and lower limit settings for voltage, current and power in the LIMIT system. This creates a GO band (shown in green in the illustrations below) and a NoGo area. If the measurements fall inside the green zone, the test continues with the next step in an auto sequence. If not, a NoGo condition is flagged. Go/NoGo has different implications depending on the operating mode selected. This is illustrated in the diagrams below.

#### 6.3.2 Go/NoGo Testing in CC Mode

In constant current mode, the voltage limits are used to determine the pass or fail area for the input voltage.

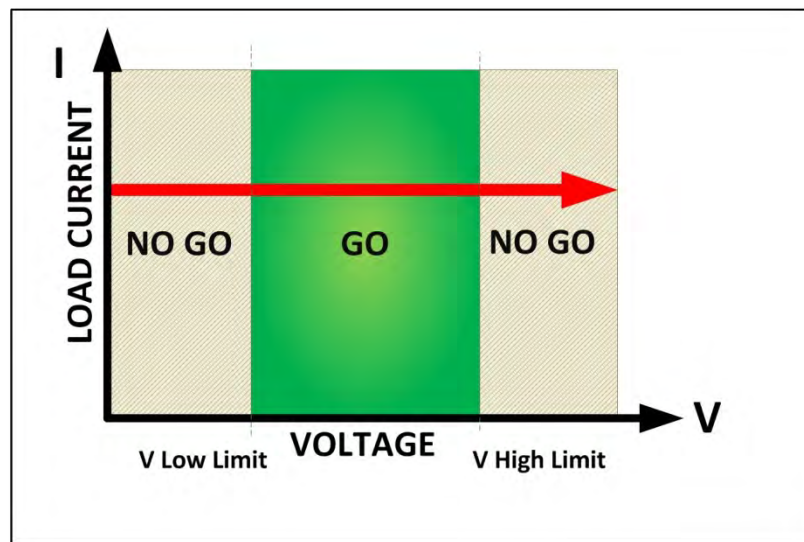

Figure 6-8: LIMIT Test in CC Mode

### 6.3.3 Go/NoGo Testing in CC Dynamic Mode

In dynamic constant current mode, the voltage limits are used to determine the pass or fail area for the input voltage.

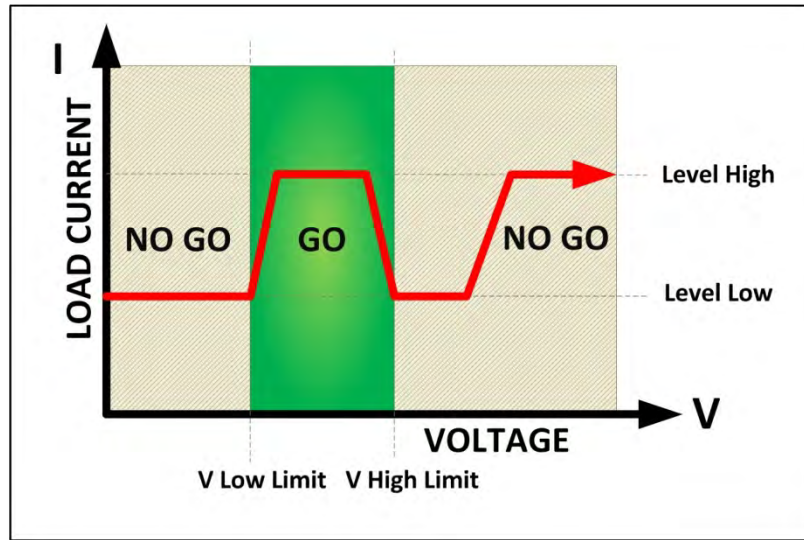

Figure 6-9: LIMIT Test in Dynamic CC Mode

### 6.3.4 Go/NoGo Testing in CR Mode

In constant resistance mode, the voltage limits are used to determine the pass or fail area for the input voltage.

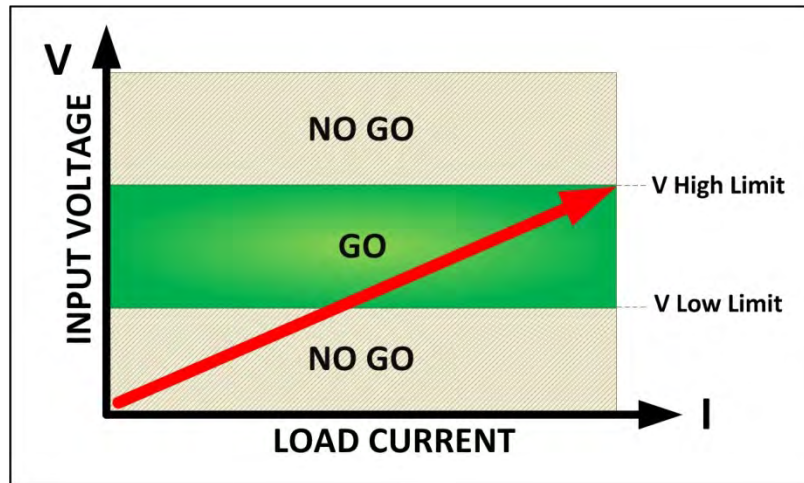

Figure 6-10: LIMIT Test in CR Mode

### 6.3.5 Go/NoGo Testing in CV Mode

In constant voltage mode, the current limits are used to determine the pass or fail area for the load current.

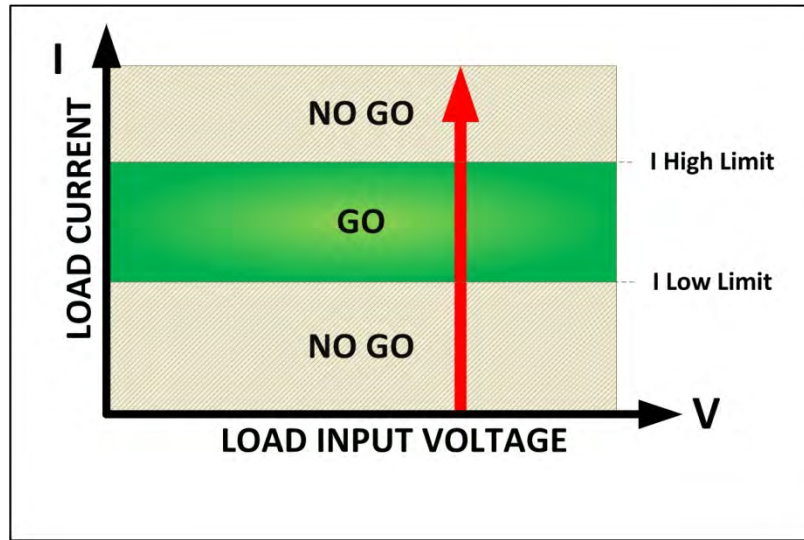

Figure 6-11: LIMIT Test in CV Mode

### 6.3.6 Go/NoGo Testing in CP Mode

In constant power mode, the current limits are used to determine the pass or fail area for the input voltage.

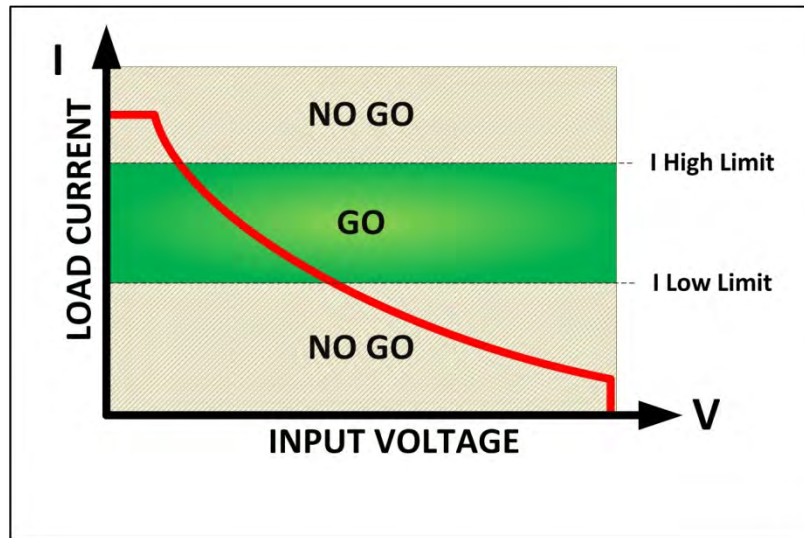

Figure 6-12: LIMIT Test in CP Mode

## 6.4 Initial Power-on Settings

When power up the 5VP Series Cabinet electronic loads, the initial load settings after power ON are as shown in the tables below respectively by model number. These are the factory default settings.

### 6.4.1 Model 5VP05-100 Power-on Settings

Item		Initial value	Item	Initial value	
CC L+Preset		0.000 A	LIMIT	V_Hi	60.00 V
CC H+Preset		0.000 A		V_Lo	0.000 V
CR H+Preset		3600 Ω		I_Hi	1000.0 A
CR L+Preset		3600 Ω		I_Lo	0.00 A
CV H+Preset		60.00 V		W_Hi	5000.0 W
CV L+Preset		60.00 V		W_Lo	0.00 W
CP L+Preset		0.00 W	CONFIG	SENSE	Auto
CP H+Preset		0.00 W		LD-ON	4.00 V
DYN	T HI	0.050 ms		LD-OFF	0.50 V
	T LO	0.050 ms		POLAR	+LOAD
	RISE	0.240 A/μs		SHORT	Disabled
	FALL	0.240 A/μs		OPP	Disabled
			OCP	Disabled	

Table 6-1: Model 5VP05-100 Power-on Settings

### 6.4.2 Model 5VP10-100 Power-on Settings

Item		Initial value	Item	Initial value	
CC L+Preset		0.000 A	LIMIT	V_Hi	60.00 V
CC H+Preset		0.000 A		V_Lo	0.000 V
CR H+Preset		3600 Ω		I_Hi	1000.0 A
CR L+Preset		3600 Ω		I_Lo	0.00 A
CV H+Preset		60.00 V		W_Hi	10000.0 W
CV L+Preset		60.00 V		W_Lo	0.00 W
CP L+Preset		0.000 W	CONFIG	SENSE	Auto
CP H+Preset		0.000 W		LD-ON	4.00 V
DYN	T HI	0.050 ms		LD-OFF	0.50 V
	T LO	0.050 ms		POLAR	+LOAD
	RISE	0.664 A/μs		SHORT	Disabled
	FALL	0.664 A/μs		OPP	Disabled
			OCP	Disabled	

Table 6-2: Model 5VP10-100 Power-on Settings

### 6.4.3 Model 5VP15-100 Power-on Settings

Item		Initial value	Item	Initial value	
CC L+Preset		0.000 A	LIMIT	V_Hi	60.00 V
CC H+Preset		0.000 A		V_Lo	0.000 V
CR H+Preset		3600 Ω		I_Hi	1000.0 A
CR L+Preset		3600 Ω		I_Lo	0.00 A
CV H+Preset		60.00 V		W_Hi	15000.0 W
CV L+Preset		60.00 V		W_Lo	0.00 W
CP L+Preset		0.000 W	CONFIG	SENSE	Auto
CP H+Preset		0.000 W		LD-ON	4.00 V
DYN	T HI	0.050 ms		LD-OFF	0.50 V
	T LO	0.050 ms		POLAR	+LOAD
	RISE	0.664 A/μs	SHORT	Disabled	
	FALL	0.664 A/μs	OPP	Disabled	
			OCP	Disabled	

Table 6-3: Model 5VP15-100 Power-on Settings

### 6.4.4 Model 5VP20-100 Power-on Settings

Item		Initial value	Item	Initial value	
CC L+Preset		0.000 A	LIMIT	V_Hi	60.00 V
CC H+Preset		0.000 A		V_Lo	0.000 V
CR H+Preset		3600 Ω		I_Hi	1000.0 A
CR L+Preset		3600 Ω		I_Lo	0.00 A
CV H+Preset		60.00 V		W_Hi	200000.0 W
CV L+Preset		60.00 V		W_Lo	0.00 W
CP L+Preset		0.000 W	CONFIG	SENSE	Auto
CP H+Preset		0.000 W		LD-ON	4.00 V
DYN	T HI	0.050 ms		LD-OFF	0.50 V
	T LO	0.050 ms		POLAR	+LOAD
	RISE	0.664 A/μs	SHORT	Disabled	
	FALL	0.664 A/μs	OPP	Disabled	
			OCP	Disabled	

Table 6-4: Model 5VP20-100 Power-on Settings

#### 6.4.5 Model 5VP25-100 Power-on Settings

Item		Initial value	Item	Initial value	
CCL+Preset		0.000 A	LIMIT	V_Hi	60.00 V
CC H+Preset		0.000 A		V_Lo	0.000 V
CR H+Preset		3600 Ω		I_Hi	1000.0 A
CR L+Preset		3600 Ω		I_Lo	0.00 A
CV H+Preset		60.00 V		W_Hi	25000.0 W
CV L+Preset		60.00 V		W_Lo	0.00 W
CP L+Preset		0.000 W	CONFIG	SENSE	Auto
CP H+Preset		0.000 W		LD-ON	4.00 V
DYN	T HI	0.050 ms		LD-OFF	0.50 V
	T LO	0.050 ms		POLAR	+LOAD
	RISE	0.664 A/μs	SHORT		Disabled
	FALL	0.664 A/μs	OPP		Disabled
			OCP		Disabled

Table 6-5: Model 5VP25-100 Power-on Settings

#### 6.4.6 Model 5VP30-100 Power-on Settings

Item		Initial value	Item	Initial value	
CC L+Preset		0.000 A	LIMIT	V_Hi	60.00 V
CC H+Preset		0.000 A		V_Lo	0.000 V
CR H+Preset		3600 Ω		I_Hi	1000.0 A
CR L+Preset		3600 Ω		I_Lo	0.00 A
CV H+Preset		60.00 V		W_Hi	30000.0 W
CV L+Preset		60.00 V		W_Lo	0.00 W
CP L+Preset		0.000 W	CONFIG	SENSE	Auto
CP H+Preset		0.000 W		LD-ON	4.00 V
DYN	T HI	0.050 ms		LD-OFF	0.50 V
	T LO	0.050 ms		POLAR	+LOAD
	RISE	0.664 A/μs	SHORT		Disabled
	FALL	0.664 A/μs	OPP		Disabled
			OCP		Disabled

Table 6-6: Model 5VP30-100 Power-on Settings

### 6.4.7 Model 5VP05-16 Power-on Settings

Item		Initial value	Item	Initial value	
CC L+Preset		0.000 A	LIMIT	V_Hi	600.00 V
CC H+Preset		0.000 A		V_Lo	0.000 V
CR H+Preset		15000 Ω		I_Hi	160.00 A
CR L+Preset		15000 Ω		I_Lo	0.00 A
CV H+Preset		600.00 V		W_Hi	5000.0 W
CV L+Preset		600.00 V		W_Lo	0.00 W
CP L+Preset		0.000 W	CONFIG	SENSE	Auto
CP H+Preset		0.000 W		LD-ON	4.00 V
DYN	T HI	0.050 ms		LD-OFF	0.50 V
	T LO	0.050 ms		POLAR	+LOAD
	RISE	0.128 A/μs	SHORT	Disabled	
	FALL	0.128 A/μs	OPP	Disabled	
			OCP	Disabled	

*Table 6-7: Model 5VP05-16 Power-on Settings*

### 6.4.8 Model 5VP10-32 Power-on Settings

Item		Initial value	Item	Initial value	
CC L+Preset		0.000 A	LIMIT	V_Hi	600.00 V
CC H+Preset		0.000 A		V_Lo	0.000 V
CR H+Preset		12500 Ω		I_Hi	320.00 A
CR L+Preset		12500 Ω		I_Lo	0.00 A
CV H+Preset		600.00 V		W_Hi	10000.0 W
CV L+Preset		600.00 V		W_Lo	0.00 W
CP L+Preset		0.000 W	CONFIG	SENSE	Auto
CP H+Preset		0.000 W		LD-ON	4.00 V
DYN	T HI	0.050 ms		LD-OFF	0.50 V
	T LO	0.050 ms		POLAR	+LOAD
	RISE	0.256 A/μs	SHORT	Disabled	
	FALL	0.256 A/μs	OPP	Disabled	
			OCP	Disabled	

*Table 6-8: Model 5VP10-32 Power-on Settings*

### 6.4.9 Model 5VP15-48 Power-on Settings

Item		Initial value	Item	Initial value	
CC L+Preset		0.000 A	LIMIT	V_Hi	600.00 V
CC H+Preset		0.000 A		V_Lo	0.000 V
CR H+Preset		15000 Ω		I_Hi	480.00 A
CR L+Preset		15000 Ω		I_Lo	0.00 A
CV H+Preset		600.00 V		W_Hi	15000.0 W
CV L+Preset		600.00 V		W_Lo	0.00 W
CP L+Preset		0.000 W	CONFIG	SENSE	Auto
CP H+Preset		0.000 W		LD-ON	4.00 V
DYN	T HI	0.050 ms		LD-OFF	0.50 V
	T LO	0.050 ms		POLAR	+LOAD
	RISE	0.384 A/μs	SHORT	Disabled	
	FALL	0.384 A/μs	OPP	Disabled	
			OCP	Disabled	

Table 6-9: Model 5VP15-48 Power-on Settings

### 6.4.10 Model 5VP20-64 Power-on Settings

Item		Initial value	Item	Initial value	
CC L+Preset		0.000 A	LIMIT	V_Hi	600.00 V
CC H+Preset		0.000 A		V_Lo	0.000 V
CR H+Preset		11250 Ω		I_Hi	640.00 A
CR L+Preset		11250 Ω		I_Lo	0.00 A
CV H+Preset		600.00 V		W_Hi	20000.0 W
CV L+Preset		600.00 V		W_Lo	0.00 W
CP L+Preset		0.000 W	CONFIG	SENSE	Auto
CP H+Preset		0.000 W		LD-ON	4.00 V
DYN	T HI	0.050 ms		LD-OFF	0.50 V
	T LO	0.050 ms		POLAR	+LOAD
	RISE	0.512 A/μs	SHORT	Disabled	
	FALL	0.512 A/μs	OPP	Disabled	
			OCP	Disabled	

Table 6-10: Model 5VP20-64 Power-on Settings

### 6.4.11 Model 5VP25-80 Power-on Settings

Item		Initial value	Item	Initial value	
CC L+Preset		0.000 A	LIMIT	V_Hi	600.00 V
CC H+Preset		0.000 A		V_Lo	0.000 V
CR H+Preset		11250 Ω		I_Hi	800.00 A
CR L+Preset		11250 Ω		I_Lo	0.00 A
CV H+Preset		600.00 V		W_Hi	25000.0 W
CV L+Preset		600.00 V		W_Lo	0.00 W
CP L+Preset		0.000 W	CONFIG	SENSE	Auto
CP H+Preset		0.000 W		LD-ON	4.00 V
DYN	T HI	0.050 ms		LD-OFF	0.50 V
	T LO	0.050 ms		POLAR	+LOAD
	RISE	0.640 A/μs	SHORT	Disabled	
	FALL	0.640 A/μs	OPP	Disabled	
			OCP	Disabled	

*Table 6-11: Model 5VP25-80 Power-on Settings*

### 6.4.12 Model 5VP30-96 Power-on Settings

Item		Initial value	Item	Initial value	
CC L+Preset		0.000 A	LIMIT	V_Hi	600.00 V
CC H+Preset		0.000 A		V_Lo	0.000 V
CR H+Preset		12500 Ω		I_Hi	960.00 A
CR L+Preset		12500 Ω		I_Lo	0.00 A
CV H+Preset		600.00 V		W_Hi	30000.0 W
CV L+Preset		600.00 V		W_Lo	0.00 W
CP L+Preset		0.000 W	CONFIG	SENSE	Auto
CP H+Preset		0.000 W		LD-ON	4.00 V
DYN	T HI	0.050 ms		LD-OFF	0.50 V
	T LO	0.050 ms		POLAR	+LOAD
	RISE	0.768 A/μs	SHORT	Disabled	
	FALL	0.768 A/μs	OPP	Disabled	
			OCP	Disabled	

*Table 6-12: Model 5VP30-96 Power-on Settings*

### 6.4.13 Model 5VP40-128 Power-on Settings

Item		Initial value	Item	Initial value	
CC L+Preset		0.000 A	LIMIT	V_Hi	600.00 V
CC H+Preset		0.000 A		V_Lo	0.000 V
CR H+Preset		1400 Ω		I_Hi	1280.00 A
CR L+Preset		1400 Ω		I_Lo	0.00 A
CV H+Preset		600.00 V		W_Hi	40000.0 W
CV L+Preset		600.00 V		W_Lo	0.00 W
CP L+Preset		0.000 W	CONFIG	SENSE	Auto
CP H+Preset		0.000 W		LD-ON	4.00 V
DYN	T HI	0.050 ms		LD-OFF	0.50 V
	T LO	0.050 ms		POLAR	+LOAD
	RISE	0.040 A/μs	SHORT	Disabled	
	FALL	0.040 A/μs	OPP	Disabled	
			OCP	Disabled	

*Table 6-13: Model 5VP40-128 Power-on Settings*

### 6.4.14 Model 5VP50-21 Power-on Settings

Item		Initial value	Item	Initial value	
CC L+Preset		0.000 A	LIMIT	V_Hi	600.00 V
CC H+Preset		0.000 A		V_Lo	0.000 V
CR H+Preset		8571 Ω		I_Hi	210.00 A
CR L+Preset		8571 Ω		I_Lo	0.00 A
CV H+Preset		600.00 V		W_Hi	50000.0 W
CV L+Preset		600.00 V		W_Lo	0.00 W
CP L+Preset		0.000 W	CONFIG	SENSE	Auto
CP H+Preset		0.000 W		LD-ON	4.00 V
DYN	T HI	0.050 ms		LD-OFF	0.50 V
	T LO	0.050 ms		POLAR	+LOAD
	RISE	0.168 A/μs	SHORT	Disabled	
	FALL	0.168 A/μs	OPP	Disabled	
			OCP	Disabled	

*Table 6-14: Model 5VP50-21 Power-on Settings*

### 6.4.15 Model 5VP60-24 Power-on Settings

Item		Initial value	Item	Initial value	
CC L+Preset		0.000 A	LIMIT	V_Hi	600.00 V
CC H+Preset		0.000 A		V_Lo	0.000 V
CR H+Preset		7500 Ω		I_Hi	240.00 A
CR L+Preset		7500 Ω		I_Lo	0.00 A
CV H+Preset		600.00 V		W_Hi	60000.0 W
CV L+Preset		600.00 V		W_Lo	0.00 W
CP L+Preset		0.000 W	CONFIG	SENSE	Auto
CP H+Preset		0.000 W		LD-ON	4.00 V
DYN	T HI	0.050 ms		LD-OFF	0.50 V
	T LO	0.050 ms		POLAR	+LOAD
	RISE	0.192 A/μs	SHORT	Disabled	
	FALL	0.192 A/μs	OPP	Disabled	
			OCP	Disabled	

*Table 6-15: Model 5VP60-24 Power-on Settings*

### 6.4.16 Model 5VP05-05 Power-on Settings

Item		Initial value	Item	Initial value	
CC L+Preset		0.000 A	LIMIT	V_Hi	1000.0 V
CC H+Preset		0.000 A		V_Lo	0.000 V
CR H+Preset		24000 Ω		I_Hi	50.000 A
CR L+Preset		24000 Ω		I_Lo	0.00 A
CV H+Preset		1000.0 V		W_Hi	5000.0 W
CV L+Preset		1000.0 V		W_Lo	0.00 W
CP L+Preset		0.000 W	CONFIG	SENSE	Auto
CP H+Preset		0.000 W		LD-ON	4.00 V
DYN	T HI	0.050 ms		LD-OFF	0.50 V
	T LO	0.050 ms		POLAR	+LOAD
	RISE	0.04 A/μs	SHORT	Disabled	
	FALL	0.04 A/μs	OPP	Disabled	
			OCP	Disabled	

*Table 6-16: Model 5VP05-05 Power-on Settings*

### 6.4.17 Model 5VP10-10 Power-on Settings

Item		Initial value	Item	Initial value	
CC L+Preset		0.000 A	LIMIT	V_Hi	1000.0 V
CC H+Preset		0.000 A		V_Lo	0.000 V
CR H+Preset		12000 Ω		I_Hi	100.00 A
CR L+Preset		12000 Ω		I_Lo	0.00 A
CV H+Preset		1000.0 V		W_Hi	10000.0 W
CV L+Preset		1000.0 V		W_Lo	0.00 W
CP L+Preset		0.000 W	CONFIG	SENSE	Auto
CP H+Preset		0.000 W		LD-ON	4.00 V
DYN	T HI	0.050 ms		LD-OFF	0.50 V
	T LO	0.050 ms		POLAR	+LOAD
	RISE	0.08 A/μs	SHORT	Disabled	
	FALL	0.08 A/μs	OPP	Disabled	
			OCP	Disabled	

*Table 6-17: Model 5VP10-10 Power-on Settings*

### 6.4.18 Model 5VP15-15 Power-on Settings

Item		Initial value	Item	Initial value	
CC L+Preset		0.000 A	LIMIT	V_Hi	1000.0 V
CC H+Preset		0.000 A		V_Lo	0.000 V
CR H+Preset		8000 Ω		I_Hi	150.00 A
CR L+Preset		8000 Ω		I_Lo	0.00 A
CV H+Preset		1000.0 V		W_Hi	15000.0 W
CV L+Preset		1000.0 V		W_Lo	0.00 W
CP L+Preset		0.000 W	CONFIG	SENSE	Auto
CP H+Preset		0.000 W		LD-ON	4.00 V
DYN	T HI	0.050 ms		LD-OFF	0.50 V
	T LO	0.050 ms		POLAR	+LOAD
	RISE	0.12 A/μs	SHORT	Disabled	
	FALL	0.12 A/μs	OPP	Disabled	
			OCP	Disabled	

*Table 6-18: Model 5VP15-15 Power-on Settings*

#### 6.4.19 Model 5VP20-20 Power-on Settings

Item		Initial value	Item	Initial value	
CC L+Preset		0.000 A	LIMIT	V_Hi	1000.0 V
CC H+Preset		0.000 A		V_Lo	0.000 V
CR H+Preset		6000 Ω		I_Hi	200.00 A
CR L+Preset		6000 Ω		I_Lo	0.00 A
CV H+Preset		1000.0 V		W_Hi	20000.0 W
CV L+Preset		1000.0 V		W_Lo	0.00 W
CP L+Preset		0.000 W	CONFIG	SENSE	Auto
CP H+Preset		0.000 W		LD-ON	4.00 V
DYN	T HI	0.050 ms		LD-OFF	0.50 V
	T LO	0.050 ms		POLAR	+LOAD
	RISE	0.16 A/μs	SHORT	Disabled	
	FALL	0.16 A/μs	OPP	Disabled	
			OCP	Disabled	

*Table 6-19: Model 5VP20-20 Power-on Settings*

#### 6.4.20 Model 5VP25-25 Power-on Settings

Item		Initial value	Item	Initial value	
CC L+Preset		0.000 A	LIMIT	V_Hi	1000.0 V
CC H+Preset		0.000 A		V_Lo	0.000 V
CR H+Preset		4800 Ω		I_Hi	250.00 A
CR L+Preset		4800 Ω		I_Lo	0.00 A
CV H+Preset		1000.0 V		W_Hi	25000.0 W
CV L+Preset		1000.0 V		W_Lo	0.00 W
CP L+Preset		0.000 W	CONFIG	SENSE	Auto
CP H+Preset		0.000 W		LD-ON	4.00 V
DYN	T HI	0.050 ms		LD-OFF	0.50 V
	T LO	0.050 ms		POLAR	+LOAD
	RISE	0.20 A/μs	SHORT	Disabled	
	FALL	0.20 A/μs	OPP	Disabled	
			OCP	Disabled	

*Table 6-20: Model 5VP25-25 Power-on Settings*

### 6.4.21 Model 5VP30-30 Power-on Settings

Item		Initial value	Item	Initial value	
CC L+Preset		0.000 A	LIMIT	V_Hi	1000.0 V
CC H+Preset		0.000 A		V_Lo	0.000 V
CR H+Preset		4000 Ω		I_Hi	300.00 A
CR L+Preset		4000 Ω		I_Lo	0.00 A
CV H+Preset		1000.0 V		W_Hi	30000.0 W
CV L+Preset		1000.0 V		W_Lo	0.00 W
CP L+Preset		0.000 W	CONFIG	SENSE	Auto
CP H+Preset		0.000 W		LD-ON	4.00 V
DYN	T HI	0.050 ms		LD-OFF	0.50 V
	T LO	0.050 ms		POLAR	+LOAD
	RISE	0.24 A/μs	SHORT	Disabled	
	FALL	0.24 A/μs	OPP	Disabled	
			OCP	Disabled	

*Table 6-21: Model 5VP30-30 Power-on Settings*

### 6.4.22 Model 5VP35-35 Power-on Settings

Item		Initial value	Item	Initial value	
CC L+Preset		0.000 A	LIMIT	V_Hi	1000.0 V
CC H+Preset		0.000 A		V_Lo	0.000 V
CR H+Preset		3428.4 Ω		I_Hi	350.00 A
CR L+Preset		3428.4 Ω		I_Lo	0.00 A
CV H+Preset		1000.0 V		W_Hi	35000.0 W
CV L+Preset		1000.0 V		W_Lo	0.00 W
CP L+Preset		0.000 W	CONFIG	SENSE	Auto
CP H+Preset		0.000 W		LD-ON	4.00 V
DYN	T HI	0.050 ms		LD-OFF	0.50 V
	T LO	0.050 ms		POLAR	+LOAD
	RISE	0.28 A/μs	SHORT	Disabled	
	FALL	0.28 A/μs	OPP	Disabled	
			OCP	Disabled	

*Table 6-22: Model 5VP35-35 Power-on Settings*

6.4.23 Model 5VP40-40 Power-on Settings

Item		Initial value	Item	Initial value	
CC L+Preset		0.000 A	LIMIT	V_Hi	1000.0 V
CC H+Preset		0.000 A		V_Lo	0.000 V
CR H+Preset		3000 Ω		I_Hi	400.00 A
CR L+Preset		3000 Ω		I_Lo	0.00 A
CV H+Preset		1000.0 V		W_Hi	40000.0 W
CV L+Preset		1000.0 V		W_Lo	0.00 W
CP L+Preset		0.000 W	CONFIG	SENSE	Auto
CP H+Preset		0.000 W		LD-ON	4.00 V
DYN	T HI	0.050 ms		LD-OFF	0.50 V
	T LO	0.050 ms		POLAR	+LOAD
	RISE	0.32 A/μs	SHORT	Disabled	
	FALL	0.32 A/μs	OPP	Disabled	
			OCP	Disabled	

Table 6-23: Model 5VP40-40 Power-on Settings

6.4.24 Model 5VP50-50 Power-on Settings

Item		Initial value	Item	Initial value	
CC L+Preset		0.000 A	LIMIT	V_Hi	1000.0 V
CC H+Preset		0.000 A		V_Lo	0.000 V
CR H+Preset		2500 Ω		I_Hi	500.00 A
CR L+Preset		2500 Ω		I_Lo	0.00 A
CV H+Preset		1000.0 V		W_Hi	50000.0 W
CV L+Preset		1000.0 V		W_Lo	0.00 W
CP L+Preset		0.000 W	CONFIG	SENSE	Auto
CP H+Preset		0.000 W		LD-ON	4.00 V
DYN	T HI	0.050 ms		LD-OFF	0.50 V
	T LO	0.050 ms		POLAR	+LOAD
	RISE	0.04 A/μs	SHORT	Disabled	
	FALL	0.04 A/μs	OPP	Disabled	
			OCP	Disabled	

Table 6-24: Model 5VP50-50 Power-on Settings

### 6.4.25 Model 5VP60-60 Power-on Settings

Item		Initial value	Item	Initial value	
CC L+Preset		0.000 A	LIMIT	V_Hi	1000.0 V
CC H+Preset		0.000 A		V_Lo	0.000 V
CR H+Preset		2000 Ω		I_Hi	600.00 A
CR L+Preset		2000 Ω		I_Lo	0.00 A
CV H+Preset		1000.0 V		W_Hi	60000.0 W
CV L+Preset		1000.0 V		W_Lo	0.00 W
CP L+Preset		0.000 W	CONFIG	SENSE	Auto
CP H+Preset		0.000 W		LD-ON	4.00 V
DYN	T HI	0.050 ms		LD-OFF	0.50 V
	T LO	0.050 ms		POLAR	+LOAD
	RISE	0.048 A/μs		SHORT	Disabled
	FALL	0.048 A/μs		OPP	Disabled
			OCP	Disabled	

Table 6-25: Model 5VP60-60 Power-on Settings

## 7 Rear Panel Overview, Connectors and Protection Features

This section describes the rear panel layout of the 5VP Series Cabinet DC Loads. The rear panel of the 5VP Series is shown below.

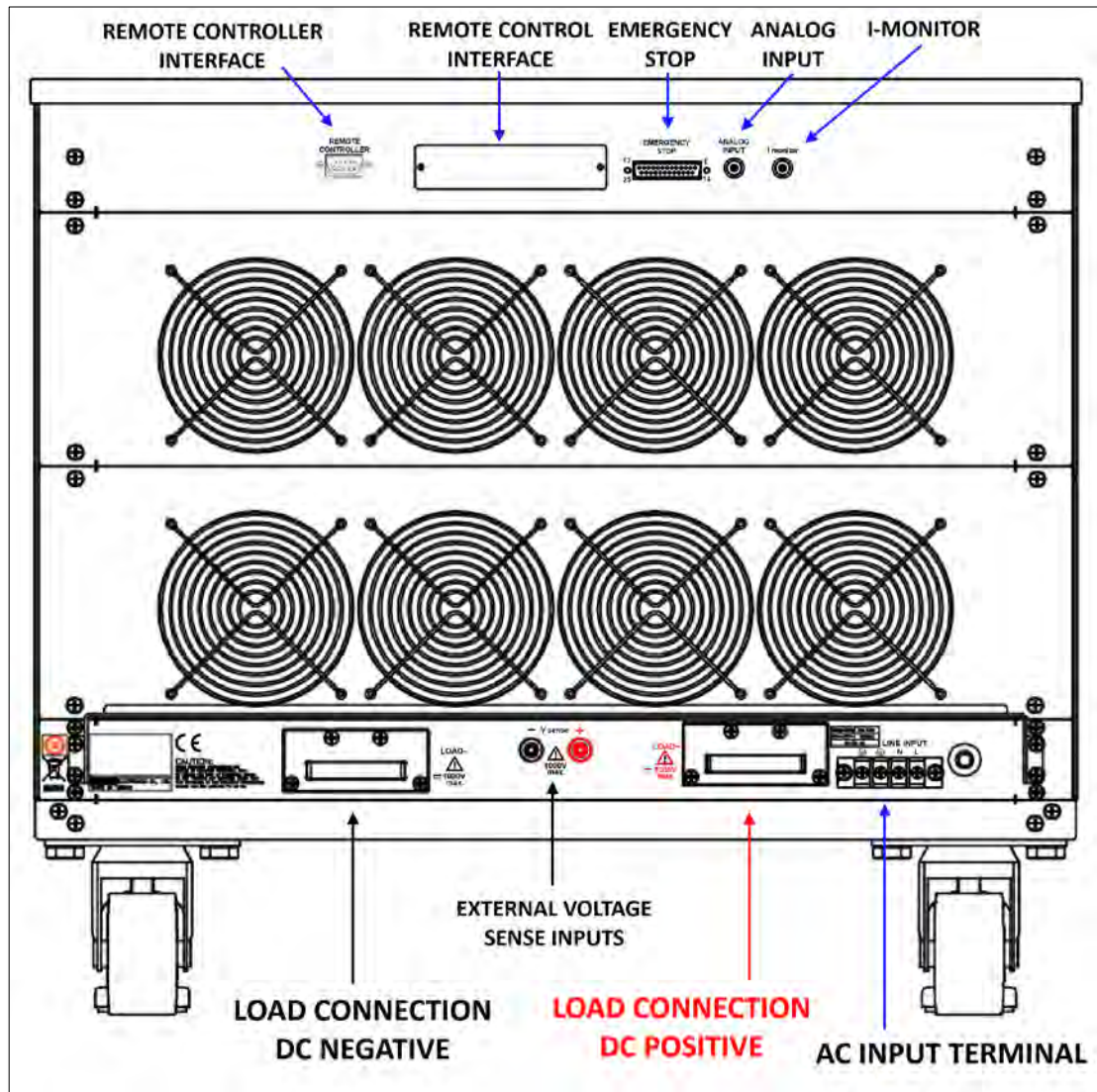

Figure 7-1: Rear Panel Connector Locations

## 7.1 DC INPUT Terminals

The positive and negative terminals for load input connection are located in the upper left hand corner of the rear panel when facing the back of the chassis.

**Note:** Always refer to Section 2.3 “Safety Information” and Section 2.4 “Safety Notices” before making any load connections.

### 7.1.1 Wire Size

A major consideration in making input connection is the wire size. The minimum wire size is required to prevent overheating and to maintain good regulation. It is recommended that the wires are sized large enough to limit the voltage drop at the maximum current rating of the DC load to less than 0.5V per lead.

### 7.1.2 Connecting a UUT

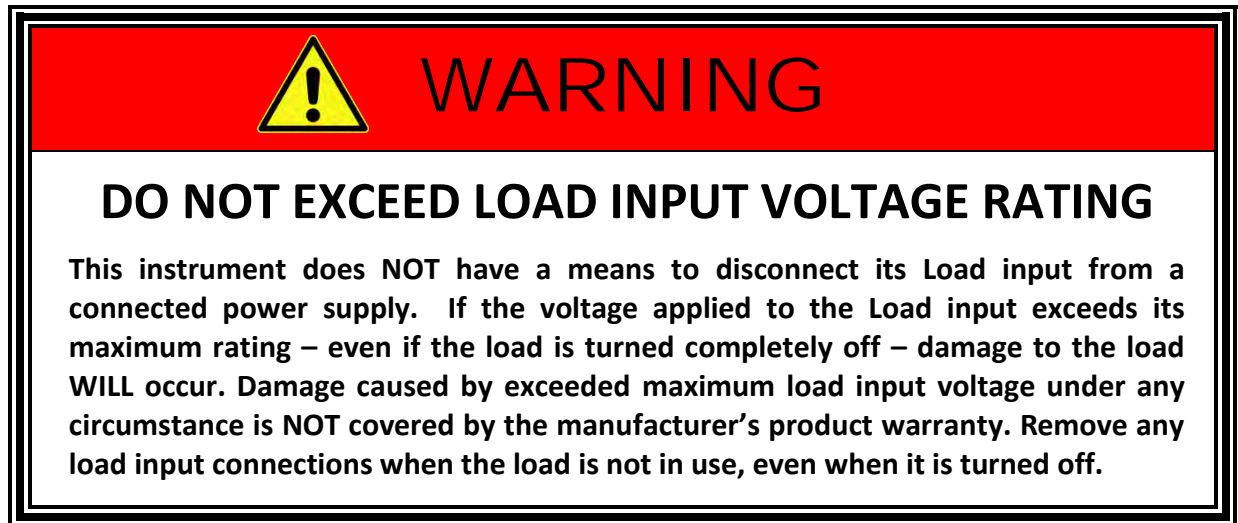

When setting up for a new test and connecting any equipment to the DC load, proceed as follows:

1. Always make sure the DC load is turned OFF at the POWER switch when making any wire connections.
2. Check that the output of the equipment under test is **OFF**.  
**Note:** Some power equipment’s output may still be energized even if the equipment has been turned off or its output is turned off. This is especially true for DC power supplies.

Note: When working with batteries, it is recommended to provide a suitable disconnect relay or switch so the load connection can be disconnected from the battery for handling purposes.

3. Connect one end of the load wires to the load input terminals on the rear panel.

4. Check the polarity of the connections and connect the other end of the load wires to the output terminal of the equipment under test.
5. When connecting multiple loads to the same EUT, make sure the load wire lengths to each load are the same.

### 7.1.3 Polarity and Ground

- It is recommended to connect the negative DC terminal to ground for positive output power supply EUTs.
- It is recommended to connect the positive DC terminal to ground for negative output power supply EUTs.

## 7.2 Voltage Sense Input Terminals

To measure the UUT output DC voltage at the UUT terminals, external voltage sense mode must be used. The external voltage sense terminal is provided for this purpose. Refer to the illustration below for details on the voltage sense terminal location and polarity.

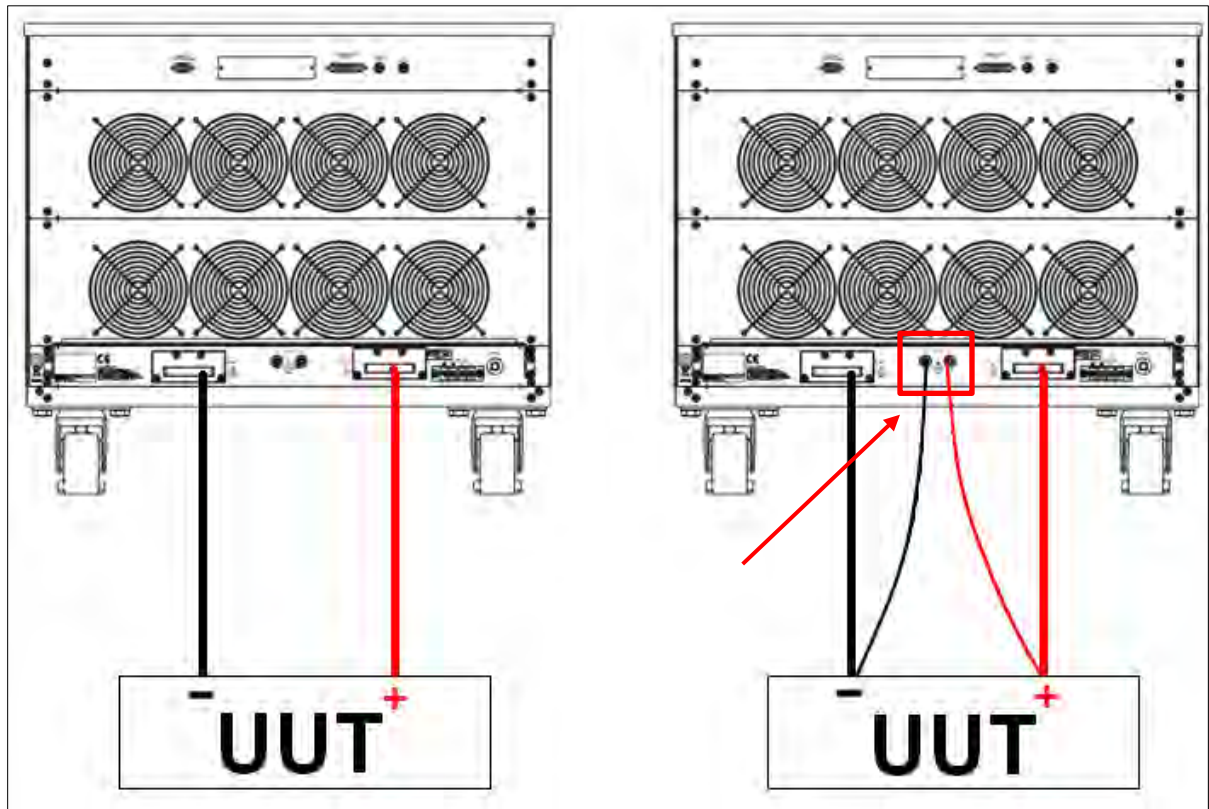

*Figure 7-2: DC Load Connections with Internal or External Voltage Sense*

### 7.3 Current Output Monitor (I-Monitor)

The I-Monitor terminal is designed to monitor the electronic load's input current or short current. An buffer amplifier output with 0V to 10V full scale output signal represents the zero to full scale current the electronic load is sinking.

Please refer to the I-Monitor voltage /current scaling values for each 5VP Series load model in Section 4, "Technical Specifications".

#### 7.3.1 Non-Isolated Output

The I-Monitor output can be used to display and capture the load current waveform on a digital storage oscilloscope to further evaluate the voltage and current waveform of a power supply under test.

**Note:** The I-Monitor is non-isolated. It is intended to support power supply development and testing and must be ground referenced.

To allow monitoring of both voltage and current simultaneously on a dual channel oscilloscope, care must be taken not to create ground loops. Most oscilloscope inputs are ground referenced and input channels are **not** isolated from each other.

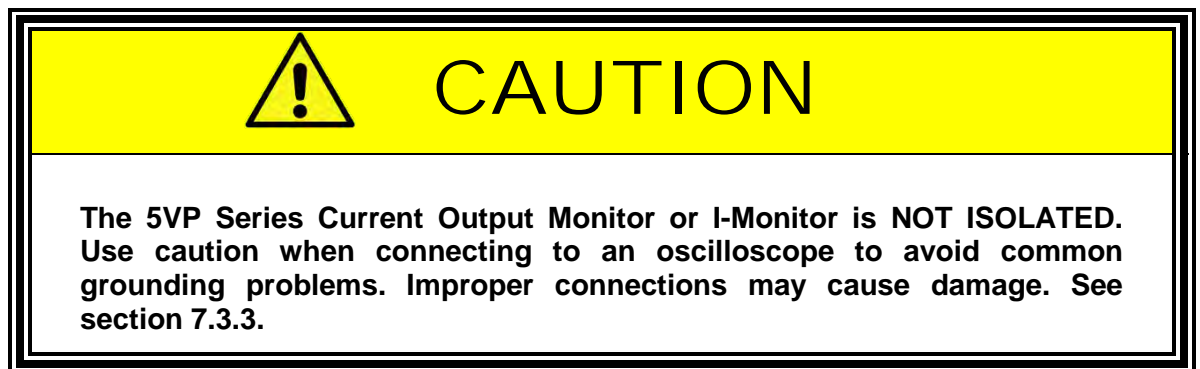

### 7.3.2 Output Impedance

The I-Monitor output volt range is 0 to 10V. Output impedance is 1K $\Omega$ . The equivalent output circuit of the I-Monitor output is shown in the figure below.

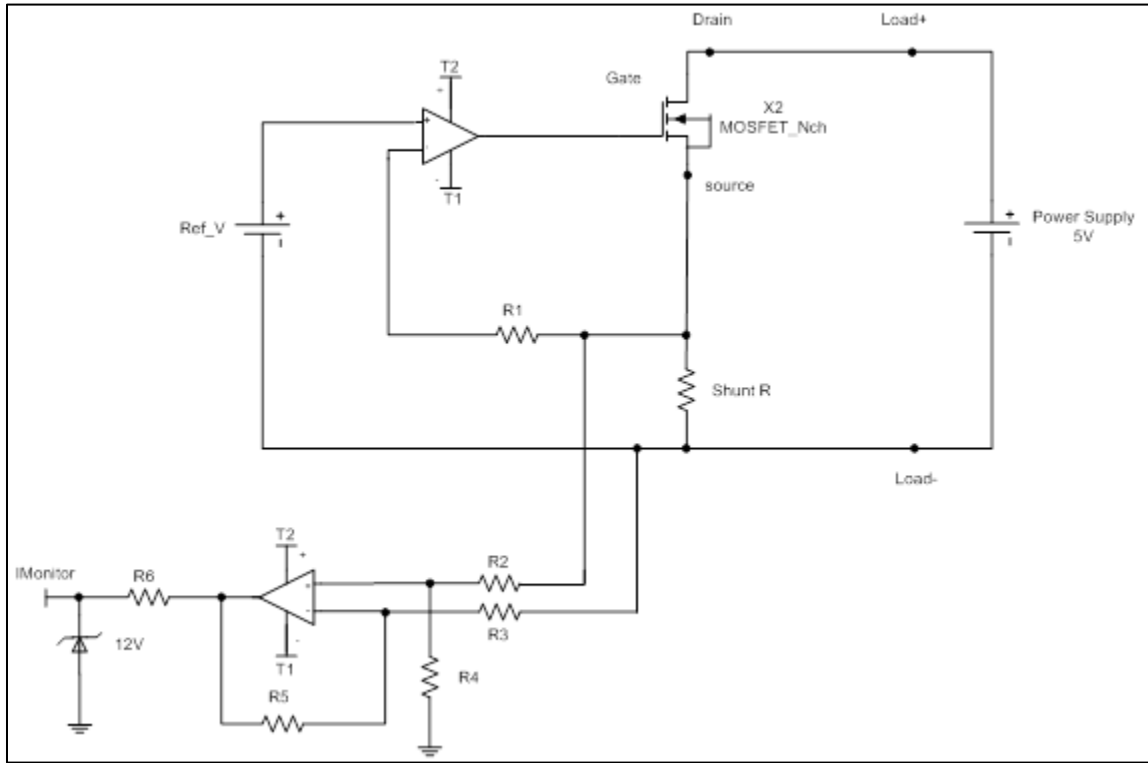

Figure 7-3: Equivalent I-Monitor Output Circuit

### 7.3.3 Connecting I-Monitor Output to an Oscilloscope

When you connect the load's current monitor to an oscilloscope, please carefully check the polarities of the scope probes of the oscilloscope as shown in Figure 7-4.

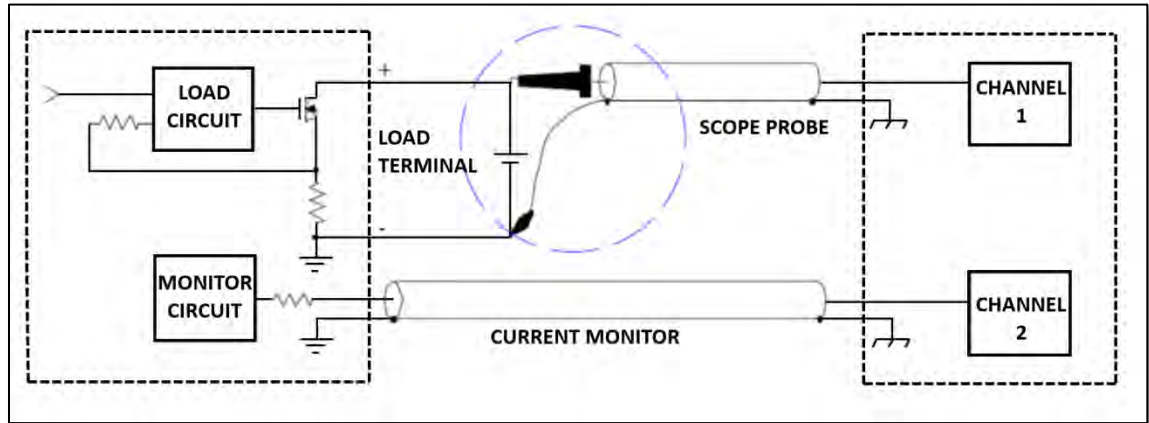

Figure 7-4: Correct I-Monitor Connections to UUT and Oscilloscope

Reversing signal and ground on the voltage probe will result in a current to flow to ground as shown in Figure 7-5 and may damage the UUT, the oscilloscope and possibly the electronic load.

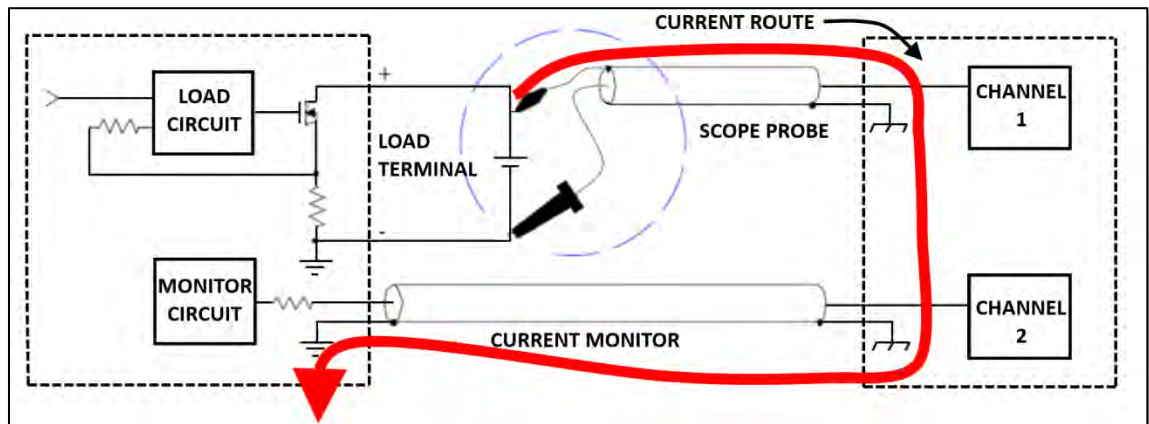

Figure 7-5: *Incorrect* I-Monitor Connections to UUT and Oscilloscope

## 7.4 Parallel Operation

It is possible to operate two or more loads in parallel if the power and/or current capability of a single load is not sufficient.

### 7.4.1 Parallel Mode Connection

The positive and negative outputs of the power supply must be connected individually to each load's input as shown in Figure 7-6 below. The setting is made at each individual load. The total load current is the sum of the load currents being taken by each load.

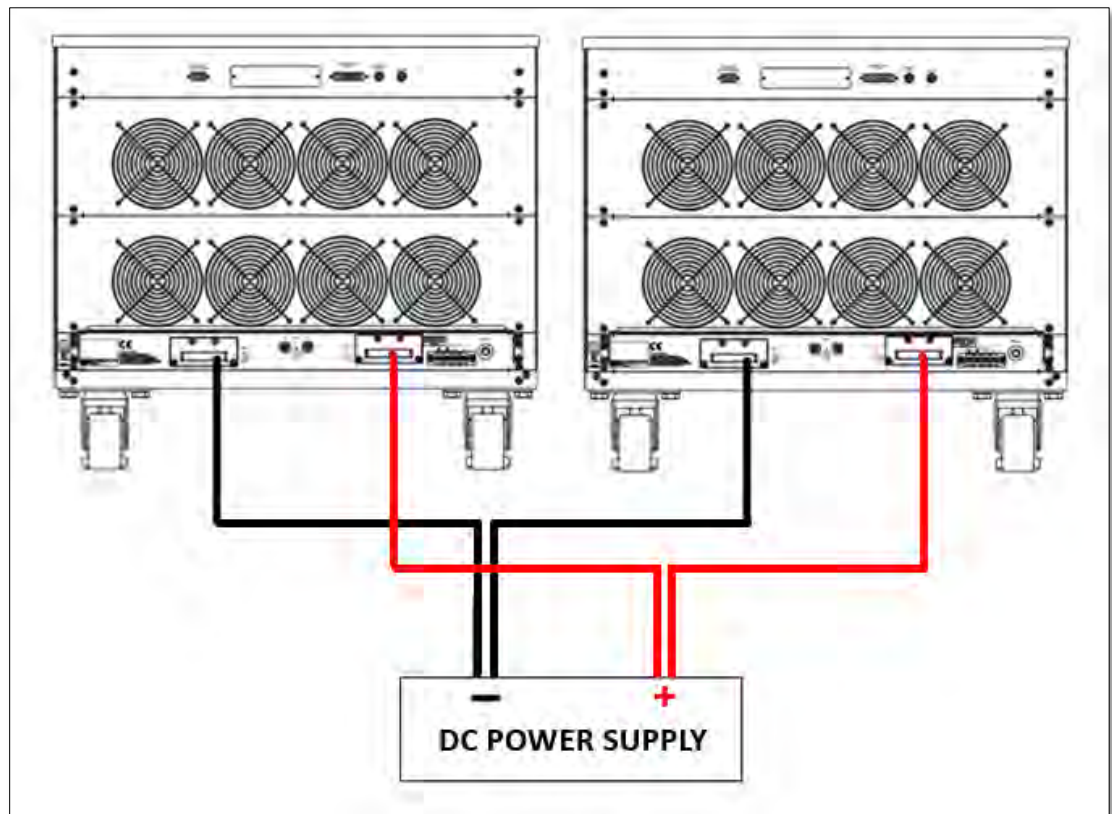

*Figure 7-6: Parallel Load Connection*

### 7.4.2 Allowable Operating Modes

It is permitted to operate loads modules with different voltage, current and power ratings to sink in parallel. For example the loads shown in Figure 7-6 could be a mixture of 5V024-08 and 5V036-12.

While in static mode, the load can be set to operate in CC, CR or CP mode.

### 7.4.3 Exceptions

1. Parallel operation in DYNAMIC mode is not allowed.
2. Parallel operation in CV mode is not possible.



### 7.5 Series Operation

Series operation of DC loads to achieve higher voltage ranges than supported by an individual load is **NOT** allowed under any circumstance.

## 7.6 Zero-Voltage Loading

As shown in Figure 7-7, the Electronic load can be connected in series with a DC voltage source (DC power supply in CV mode) with an output voltage greater than 0.7Vdc.

This allows the device under test connected to the electronic load to be operated down to a zero volt condition. The external DC voltage source provides the minimum operating voltage required by the electronic load. This application is suitable for low voltage battery cell, high discharge current testing.

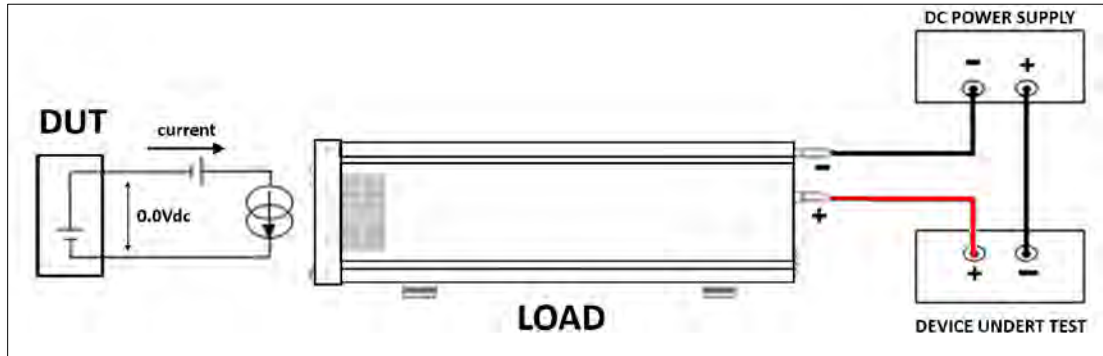

Figure 7-7: Zero Volt Load Connection

## 7.7 Protection Features

The 5VP Series Cabinet electronic loads include the following protection features:

- Over Voltage
- Over Current
- Over Power
- Over Temperature
- Reverse Polarity Indication

### 7.7.1 Over Voltage Protection

The over voltage protection circuit is set at a predetermined voltage. The OVP limit is fixed and depends on the 5VP model DC voltage range as follows:

60V models	63Vdc
600V models	630Vdc
1000V models	1040Vdc

These OVP limits are intended to protect the DC load from overvoltage conditions and **cannot** be changed. If the over voltage circuit has tripped, the load input turns OFF immediately to prevent damaging the load. When an over voltage trip condition has occurred, the digital current meter's LCD display will indicate "OVP".

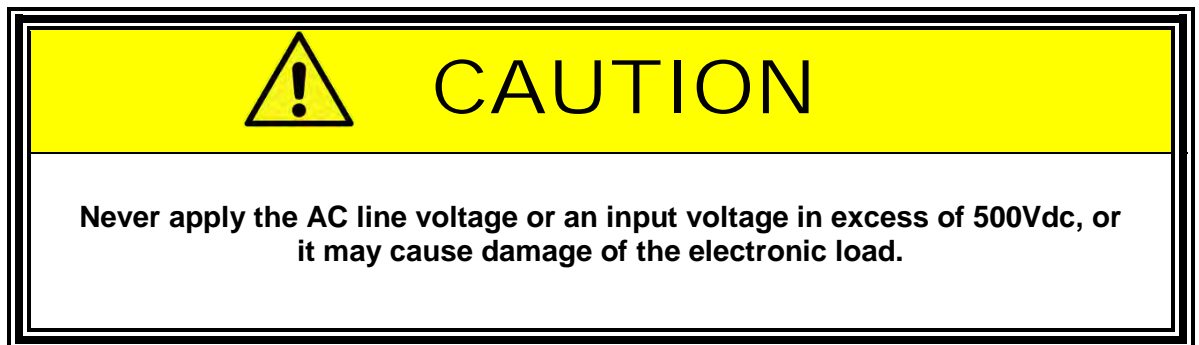

### 7.7.2 Over Current Protection

The load always monitors the current it is sinking. When the current sink is greater than 105% of the rated maximum current, the load will turn to OFF state internally. When an over current condition has occurred, the digital current meter's LCD display will indicate "OCP".

### 7.7.3 Over Power Protection

The load always monitors the power dissipated by the load. When the power dissipation is greater than 105% of the rated power input, the load will turn to OFF state internally. When an over power condition has occurred, the digital current meter's LCD display will indicate "OPP".

#### 7.7.4 Over Temperature Protection

As soon as the temperature of load's internal heat sinks reaches a level greater than 85° C (180° F), the over temperature protection is triggered. The digital current meter's LCD display will indicate "OTP". The Load will turn to the OFF state internally.

Please check environmental conditions such as the ambient temperature and distance between the rear panel of the load chassis and any wall is greater than 15cm / 6 inches.

The load can reset the Over Voltage, Over Current, Over Power and Over Temperature protection if the condition that caused the fault is removed and the "LOAD" key is pressed to set "ON" state.

#### 7.7.5 Reverse Polarity Protection Indication

The 5VP Series Cabinet electronic load conducts reverse current when the polarity of the DC source connection is incorrect. The maximum reverse current is based on the maximum current rating of the 5VP model. If the reverse current exceeds the maximum reverse current, it may damage the load.

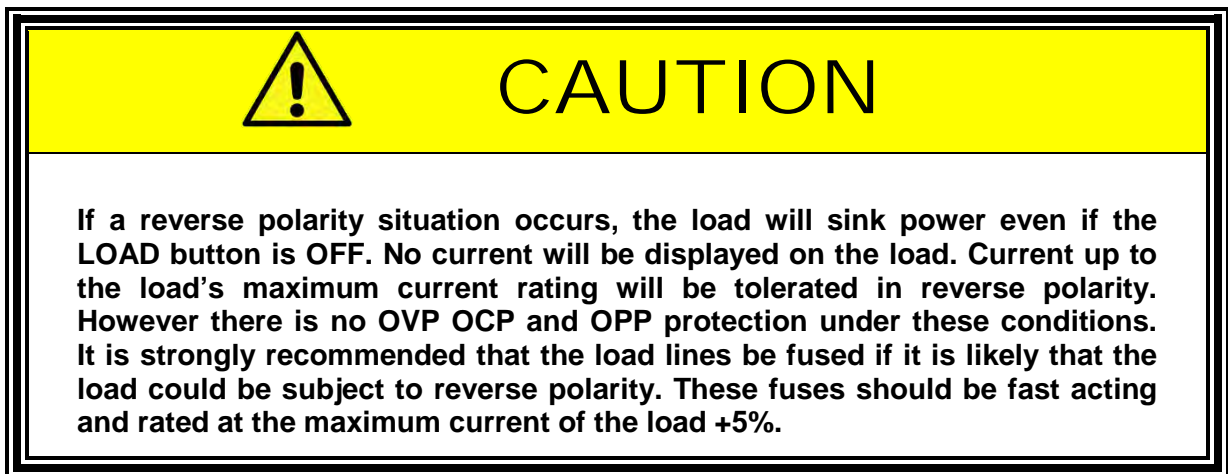

## 8 Remote Control Programming

### 8.1 Overview

If the load is fitted with a computer interface option then a GPIB, RS232, USB or LAN connector will be present on the rear panel based on the order configuration. The interface allows the load settings to be configured remotely and measurement data to be retrieved for analysis and test report generation.

There are two sets of programming commands for APS Loads. One is referred to as the SHORT FORM commands and the other set as the LONG FORM commands.

For Example

To query the actual voltage present at the load from the load's measurement system, the long form command is:

*MEASURE:VOLTAGE?*

The same command in its short form is:

*MEAS:VOLT?*

**NOTE:** When either one of the RS232, USB or LAN interface options is used to control the load, it is important to send the "REMOTE" command first to make sure the load is in REMOTE state. To return the load to local operation, the "LOCAL" command is used. These two commands do not apply to the GPIB interface as remote and local state of an instrument is handled through the GPIB ATN hardware signal per the IEEE488 standard.

## 8.2 RS232 Set-up

The RS232 interface of the APS load is configured as follows:

Baud-rate: 9600 - 115200bps (selectable using the SYSTEM key)  
 Parity: None  
 Data bit: 8 bits  
 Stop bit: 1 bit  
 Handshaking: Hardware (RTS/CTS).

Make sure the settings used on the controller's COM port match those of the load.

The RS232 Interface connector DB9 pin-out of the load is shown in Table 8-1.

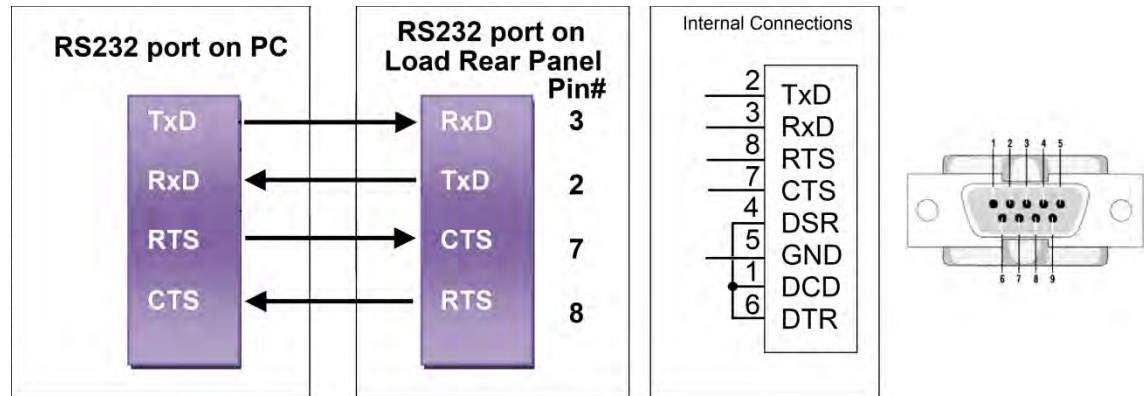

Figure 8-1: RS232 Connection to PC and DB9 Pin out

Signal Pin Assignments:

PIN	Abbreviation	Description
Pin1	DCD	Direct Carrier Detect
Pin2	TXD	Transmit Data
Pin3	RXD	Receive Data
Pin4	DTR	Data Terminal Ready
Pin5	GND	Ground
Pin6	DSR	Data Set Ready
Pin7	RTS	Request To Send
Pin8	CTS	Clear To Send
Pin9	RI	Ring Indicator

Table 8-1: RS232 DB9 Pin Assignments

## 8.3 Programming Syntax

A variety of syntax notations are used in the description of the remote control commands and in the summary tables. The syntax used is defined as follows:

- SP Space, the ASCII code is 20 hexadecimal.
- ; Semicolon, program line terminator, the ASCII code is 0A hexadecimal.
- NL New line, program line terminator, the ASCII code is 0A hexadecimal.
- NR2 Numeric value with decimal point. Values can be accepted in the range and format of ###.#####. For example: 30.12345. In this instance, the load will read up to five significant digits after the decimal point. The decimal point can be omitted if not required.

### 8.3.1 Parenthesis

The following parentheses are used in the command descriptions to indicate whether a command is necessary or optional and whether a choice has to be made. The symbols { }, [ ], | are not actually used in the programming commands. The symbols { }, [ ] and | are merely used to illustrate the command syntax.

- |                      |   |
|----------------------|---|
| { } - Required:      | The contents of the { } symbol must be used as part of the command, it cannot be omitted.   |
| [ ] - Optional:      | The contents of the [ ] symbol indicates that the command is optional. The use of the contents depends on the test application.   |
| - Required Choice:   | This symbol means a choice must be made between the stated command key words. For example, "LOW HIGH" Means a LOW or HIGH choice needs to be made as part of the command. |
| ? - Required Choice: | The question mark implies the query format of the command.  |

### 8.3.2 Terminators

All remote control commands sent to the load must be terminated with a command terminator. The command terminator characters accepted by the APS loads are listed in Table 8-2.

Terminator	Hex Code	Decimal	C Code	Notes
<b>LF</b>	0x0A	10	\n	
<b>LF+ EOI</b>	0x0A	10	\n	GPIB only
<b>CR+LF</b>	0x0D + 0x0A	13 + 10	\r\n	
<b>CR+LF+EOI</b>	0x0D + 0x0A	13 + 10	\r\n	GPIB only

*Table 8-2: Supported Command Terminators*

Semicolon “;” The semicolon character allows you to combine multiple commands in one message string to create a command sequence. The commands will be parsed in the order in which they are received.

## 8.4 Short Form Command Syntax

The setting and query commands for the 5VP Series Cabinet are listed in the summary tables below. Short form commands use an abbreviated syntax, which reduces the amount of characters required for each command and thus increases throughput.

SETTING COMMAND SUMMARY	REMARK
RISE{SP} {NR2};;   NL}	(m)A/us
FALL{SP} {NR2} ;;   NL}	(m)A/us
PERD:{HIGH LOW} {SP} {NR2} ;;   NL}	
LDONV{SP} {NR2} ;;   NL}	
LDOFFV{SP} {NR2} ;;   NL}	
CC   CURR:{HIGH LOW} {SP} {NR2};;   NL}	
CP: {HIGH LOW} {SP} {NR2};;   NL}	
CR   RES:{HIGH LOW} {SP} {NR2};;   NL}	
CV   VOLT:{HIGH LOW} {SP} {NR2};;   NL}	
TCONFIG {SP} {NORMAL OCP   OPP  SHORT} ;;   NL}	
OCP:START {SP} {NR2} ;;   NL}	
OCP:STEP {SP} {NR2} ;;   NL}	
OCP:STOP {SP} {NR2} ;;   NL}	
VTH {SP} {NR2} ;;   NL}	
OPP:START {SP} {NR2} ;;   NL}	
OPP:STEP {SP} {NR2} ;;   NL}	
OPP:STOP {SP} {NR2} ;;   NL}	
STIME {SP} {NR2} ;;   NL}	

Table 8-3: Setting Commands - Short Form

SETTING QUERY COMMAND SUMMARY	RETURN FORMAT
RISE {?} {} ;   NL}	###.####
FALL {?} {} ;   NL}	###.####
PERD:{HIGH LOW}{?} {} ;   NL}	###.####
LDONV {?} {} ;   NL}	###.####
LDOFFV {?} {} ;   NL}	###.####
CC   CURR:{HIGH LOW} {?} {} ;   NL}	###.####
CP: {HIGH LOW} {?} {} ;   NL}	###.####
CR   RES:{HIGH LOW} {?} {} ;   NL}	###.####
CV   VOLT:{HIGH LOW} {?} {} ;   NL}	###.####
TCONFIG {?} {} ;   NL}	1:NORMAL
	2:OCP
	3:OPP
	4:SHORT
OCP: START {?} {} ;   NL}	###.####
OCP: STEP {?} {} ;   NL}	###.####
OCP: STOP {?} {} ;   NL}	###.####
VTH {?} {} ;   NL}	###.####
OPP: START {?} {} ;   NL}	###.####
OPP: STEP {?} {} ;   NL}	###.####
OPP: STOP {?} {} ;   NL}	###.####
STIME {?} {} ;   NL}	###.####
OCP {?} {} ;   NL}	###.####
OPP {?} {} ;   NL}	###.####

Table 8-4: Query Commands - Short Form

LIMIT COMMAND SUMMARY	RETURN FORMAT
IH   IL{SP}{NR2} {} ;   NL}	
IH   IL{?} {} ;   NL}	
WH   WL{SP}{NR2} {} ;   NL}	
WH   WL{?} {} ;   NL}	###.####
VH   VL{SP}{NR2} {} ;   NL}	
VH   VL{?} {} ;   NL}	###.####
SVH   SVL{SP}{NR2} {} ;   NL}	
SVH   SVL{?} {} ;   NL}	###.####

Table 8-5: Limit Commands - Short Form

STATE COMMAND SUMMARY	REMARK
LOAD {SP}{ON OFF 1 0} {;}   NL}	
LOAD {?} {;}   NL}	0: OFF   1: ON
MODE {SP}{CC   CR   CV   CP } {;}   NL}	
MODE {?} {;}   NL}	0: CC   1: CR 2: CV   3: CP
SHOR {SP}{ON OFF 1 0} {;}   NL}	
SHOR {?} {;}   NL}	0: OFF   1: ON
PRES {SP}{ON OFF 1 0} {;}   NL}	
PRES {?} {;}   NL}	0: OFF   1: ON
SENS {SP}{ON   OFF   AUTO 1 0} {;}   NL}	
SENS {?} {;}   NL}	0: OFF/AUTO   1: ON
LEV {SP}{ LOW HIGH 0 1} {;}   NL}	
LEV {?} {;}   NL}	0: LOW   1: HIGH
DYN {SP}{ON OFF 1 0} {;}   NL}	
DYN {?} {;}   NL}	0: OFF   1: ON
CLR {;}   NL}	
ERR {?} {;}   NL}	
NG {?} {;}   NL}	0: GO   1: NG
PROT {?} {;}   NL}	
CCR {SP}{AUTO R2} {;}   NL}	
NGENABLE {SP}{ON OFF} {;}   NL}	
POLAR {SP}{POS NEG} {;}   NL}	
START {;}   NL}	
STOP {;}   NL}	
TESTING {?} {;}   NL}	0:TEST END   1:TESTING

Table 8-6: State Commands - Short Form

SYSTEM COMMANDS	NOTES	RETURN FORMAT
RECALL {SP}{m} {;}   NL}	m=1 -150 (STATE)	
STORE {SP}{m} {;}   NL}	m=1 – 150 (STATE)	
REMOTE {;}   NL}	RS232/USB/LAN only command	
LOCAL {;}   NL}	RS232/USB/LAN only command	
NAME {?} {;}   NL}		“XXXXX”

Table 8-7: System Commands - Short Form

MEASUREMENT QUERY COMMAND SUMMARY	RETURN
MEAS:CURR {?} {;}   NL}	###.####
MEAS:VOLT {?} {;}   NL}	###.####
MEAS:POW {?} {;}   NL}	###.####

Table 8-8: Measurement Query Commands - Short Form

AUTO SEQUENCE COMMANDS	NOTES	RETURN
FILE {SP} {n} {;}   NL}	n=1 - 9	1 - 9
STEP {SP} {n} {;}   NL}	n=1 - 16	1 - 16
TOTSTEP {SP} {n} {;}   NL}	Total step n=1 - 16	1 - 16
SB {SP} {m} {;}   NL}	m=1 – 150,(STATE)	
T1 {SP} {NR2} {;}   NL}	0.1 - 9.9(s)	0.1 - 9.9 (sec)
T2 {SP} {NR2} {;}   NL}	0.1 - 9.9(s)	0.0 - 9.9 (sec)
SAVE {;}   NL}	Save "File n" data	
REPEAT {SP} {n} {;}   NL}	n=0 – 9999	0 - 9999
RUN {SP} {F} {n} {;}   NL}	n=1 - 9	AUTO REPLY "PASS" or "FAIL:XX" (XX=NG STEP)

Table 8-9: Auto Sequence Commands - Short Form

BATTERY TEST COMMAND SUMMARY	REMARKS
BATT:TYPE {SP} {n} {;}   NL}	n = 1 – 5
BATT:UVP {SP} {NR2} {;}   NL}	Unit = Volts
BATT:TIME {SP} {NR1} {;}   NL}	Time = 1 – 99999 secs.
BATT:STEP {SP} {n} {;}   NL}	TYPE4: n = 1 – 3; TYPE5: n = 1 – 9
BATT:CCH {n} {SP} {NR2} {;}   NL}	TYPE4: CC:HIGH level, n = 1 - 3
BATT:CCL {n} {SP} {NR2} {;}   NL}	TYPE4: CC:LOW level, n = 1 - 3
BATT:TH {n} {SP} {NR2} {;}   NL}	TYPE4: Thigh (unit = msec), n = 1 - 3
BATT:TL {n} {SP} {NR2} {;}   NL}	TYPE4: Tlow (unit = msec), n = 1 – 3
BATT:CYCLE {n} {SP} {NR1} {;}   NL}	TYPE4: Cycle = 1 – 2000, n = 1 - 3
BATT:CC {n} {SP} {NR2} {;}   NL}	TYPE5: Current, n = 0 – 9
BATT:DTIME {n} {SP} {NR2} {;}   NL}	TYPE5: Delta time T1 – T9: 0 – 6000 secs, n = 0 - 9
BATT:REPEAT {SP} {NR1} {;}   NL}	TYPE4 & TYPE5:Repeats = 0 - 9999
BATT:TEST {SP} {ON   OFF} {;}   NL}	ON:START TEST   OFF:STOP TEST TYPE1 & TYPE2: TEST END, AUTO ECHO "OK,XXXXX" XXXXX:AH TYPE3-5 TEST: END, AUTO ECHO "OK,XXXXX" XXXXX:DVM

Table 8-10: Battery Test Commands – Short Form

### 8.4.1 Notations and Conventions Used in programming commands:

1. Current engineering unit: A
2. Voltage engineering unit: V
3. Resistance engineering unit:  $\Omega$
4. Time Period engineering unit: ms
5. Slew-rate engineering unit: (m)A/us
6. Power engineering unit: W

## 8.5 Long Form Command Syntax

The setting and query commands for the 5VP Series Cabinet are listed in the summary tables below. Long form commands use extended command key words for easier code readability.

SETTING COMMAND SUMMARY	REMARK
[PRESet:] RISE{SP} {NR2} {;   NL}	(m)A/us
[PRESet:] FALL{SP} {;   NL}	(m)A/us
[PRESet:] PERI   PERD:HIGH   LOW {SP} {NR2} {;   NL}	
[PRESet:] LDONv{SP} {NR2} {;   NL}	
[PRESet:] LDOFv{SP} {NR2} {;   NL}	
[PRESet:] CC   CURR:{HIGH   LOW} {SP} {NR2} {;   NL}	
[PRESet:] CP: {HIGH   LOW} {SP} {NR2} {;   NL}	
[PRESet:] CR   RES:{HIGH   LOW} {SP} {NR2} {;   NL}	
[PRESet:] CV   VOLT:{HIGH   LOW} {SP} {NR2} {;   NL}	
[PRESet:] FALL{SP} {;   NL}	
[PRESet:] PERI   PERD:HIGH   LOW {SP} {NR2} {;   NL}	
[PRESet:] CV   VOLT {SP} {NR2} {;   NL}	
[PRESet:] TCONFIG {SP} {NORMAL OCP   OPP SHORT} {;   NL}	
[PRESet:] OCP:START {SP} {NR2} {;   NL}	
[PRESet:] OCP:STEP {SP} {NR2} {;   NL}	
[PRESet:] OCP:STOP {SP} {NR2} {;   NL}	
[PRESet:] VTH {SP} {NR2}{;   NL}	
[PRESet:] OPP:START {SP} {NR2}{;   NL}	
[PRESet:] OPP:STEP {SP} {NR2}{;   NL}	
[PRESet:] OPP:STOP {SP} {NR2}{;   NL}	
[PRESet:] STIME {SP} {NR2} {;   NL}	

Table 8-11: Setting Commands - Long Form

SETTING QUERY COMMAND SUMMARY	RETURN FORMAT
[PRESet:] RISE {?} {;}   NL}	###.####
[PRESet:] FALL {?} {;}   NL}	###.####
[PRESet:] PERI   PERD : {HIGH   LOW} {?} {;}   NL}	###.####
[PRESet:] LDONv {?} {;}   NL}	###.####
[PRESet:] LDOFv {?} {;}   NL}	###.####
[PRESet:] CC   CURR: {HIGH   LOW} {?} {;}   NL}	###.####
[PRESet:] CP {HIGH   LOW} {?} {;}   NL}	###.####
[PRESet:] CR   RES: {HIGH   LOW} {?} {;}   NL}	###.####
[PRESet:] CV   VOLT: {HIGH   LOW} {?} {;}   NL}	###.####
[PRESet:] TCONFIG {?} {;}   NL}	1:NORMAL 2:OCP 3:OPP 4:SHORT
[PRESet:] OCP: START {?} {;}   NL}	###.####
[PRESet:] OCP: STEP {?} {;}   NL}	###.####
[PRESet:] OCP: STOP {?} {;}   NL}	###.####
[PRESet:] VTH {?} {;}   NL}	###.####
[PRESet:] OPP: START {?} {;}   NL}	###.####
[PRESet:] OPP: STEP {?} {;}   NL}	###.####
[PRESet:] OPP: STOP {?} {;}   NL}	###.####
[PRESet:] STIME {?} {;}   NL}	###.####

Table 8-12: Query Commands - Long Form

LIMIT COMMAND SUMMARY	RETURN FORMAT
LIMit:CURRent: {HIGH   LOW} {SP} {NR2} {;}   NL}	
LIMit:CURRent: {HIGH   LOW} {?} {;}   NL}	###.####
IH   IL {SP} {NR2} {;}   NL}	
IH   IL {?} {;}   NL}	
LIMit:POWer: {HIGH   LOW} {SP} {NR2} {;}   NL}	
LIMit:POWer: {HIGH   LOW} {?} {;}   NL}	###.####
WH   WL {SP} {NR2} {;}   NL}	
WH   WL {?} {;}   NL}	###.####
LIMit:VOLTagE: {HIGH   LOW} {SP} {NR2} {;}   NL}	
LIMit:VOLTagE: {HIGH   LOW} {?} {;}   NL}	###.####
VH   VL {SP} {NR2} {;}   NL}	
VH   VL {?} {;}   NL}	###.####
SVH   SVL {SP} {NR2} {;}   NL}	
SVH   SVL {?} {;}   NL}	###.####

Table 8-13: Limit Commands - Long Form

STATE COMMAND SUMMARY	REMARK
[STATe:] LOAD {SP}{ON OFF} {;}   NL}	
[STATe:] LOAD {?} {;}   NL}	0: OFF   1: ON
[STATe:] MODE {SP} {CC   CR   CV   CP} {;}   NL}	
[STATe:] MODE {?} {;}   NL}	0: CC   1: CR 2: CV   3: CP
[STATe:] SHORt {SP} {ON OFF} {;}   NL}	
[STATe:] SHORt {?} {;}   NL}	0: OFF   1: ON
[STATe:] PRESet {SP} {ON OFF} {;}   NL}	
[STATe:] PRESet {?} {;}   NL}	0: OFF   1: ON
[STATe:] SENSE {SP} {ON AUTO} {;}   NL}	
[STATe:] SENSE {?} {;}   NL}	0: OFF/AUTO   1: ON
[STATe:] LEVEL {SP} {LOW HIGH} {;}   NL}	
[STATe:] LEVEL {?} {;}   NL}	0: LOW   1: HIGH
[STATe:] DYNamic {SP} {ON OFF} {;}   NL}	
[STATe:] DYNamic {?} {;}   NL}	0: OFF   1: ON
[STATe:] CLR {;}   NL}	
[STATe:] ERRor {?} {;}   NL}	
[STATe:] NO {SP} GOOD {?} {;}   NL}	0: GO   1: NG
[STATe:] NG {?} {;}   NL}	0: GO   1: NG
[STATe:] PROTECT {?} {;}   NL}	
[STATe:] CCR{SP}{AUTO R2} {;}   NL} (NOTE 1)	
[STATe:] NGENABLE{SP}{ON OFF} {;}   NL}	
[STATe:] POLAR{SP}{POS NEG} {;}   NL}	
[STATe:] START {;}   NL}	
[STATe:] STOP {;}   NL}	
[STATe:] TESTING {?} {;}   NL}	0:TEST END   1:TESTING

Table 8-14: State Commands - Long Form

SYSTEM COMMANDS	NOTE	RETURN FORMAT
[SYStem:] RECall {SP} {m} {;}   NL}	m=1 – 150 (STATE)	
[SYStem:] STORe {SP} {m} {;}   NL}	m=1 – 150 (STATE)	
[SYStem:] REMOTE {;}   NL}	RS232/USB/LAN command	
[SYStem:] LOCAL{;}   NL}	RS232/USB/LAN command	
[SYStem:] NAME {?} {;}   NL}		“XXXXX”
[SYStem:]*RST {;}   NL}		
[SYStem:]SYNC:LOAD {SP} {ON OFF} {;}   NL}		

Table 8-15: System Commands - Long Form

MEASUREMENT QUERY COMMAND SUMMARY	RETURN FORMAT
MEASure:CURRent {?} {;}   NL}	###.####
MEASure:VOLTage {?} {;}   NL}	###.####
MEASure:POWer {?} {;}   NL}	###.####

Table 8-16: Measurement Query Commands

AUTO SEQUENCE COMMANDS	NOTES	RETURNS
FILE {SP} {n} {;}   NL}	n=1 - 9	1 - 9
STEP {SP} {n} {;}   NL}	n=1 - 16	1 - 16
TOTSTEP {SP} {n} {;}   NL}	Total steps n=1 - 16	1 - 16
SB {SP} {m} {;}   NL}	m=1 -150, (STATE)	
T1 {SP} {NR2} {;}   NL}	0.1 - 9.9(s)	0.1 - 9.9 (sec)
T2 {SP} {NR2} {;}   NL}	0.1 - 9.9(s)	0.0 - 9.9 (sec)
SAVE {;}   NL}	Save "File n" data	
REPEAT {SP} {n} {;}   NL}	n=0 - 9999	0 - 9999
RUN {SP} {F} {n} {;}   NL}	n=1 - 9	AUTO REPLY "PASS" or "FAIL:XX" (XX=NG STEP)

Table 8-17: Auto Sequence Commands - Long Form

BATTERY TEST COMMAND SUMMARY	REMARKS
BATT:TYPE {SP} {n} {;}   NL}	n = 1 - 5
BATT:UVP {SP} {NR2} {;}   NL}	Unit = Volts
BATT:TIME {SP} {NR1} {;}   NL}	Time = 1 - 99999 secs.
BATT:STEP {SP} {n} {;}   NL}	TYPE4: n = 1 - 3; TYPE5: n = 1 - 9
BATT:CCH {n} {SP} {NR2} {;}   NL}	TYPE4: CC:HIGH level, n = 1 - 3
BATT:CCL {n} {SP} {NR2} {;}   NL}	TYPE4: CC:LOW level, n = 1 - 3
BATT:TH {n} {SP} {NR2} {;}   NL}	TYPE4: Thigh (unit = msec), n = 1 - 3
BATT:TL {n} {SP} {NR2} {;}   NL}	TYPE4: Tlow (unit = msec), n = 1 - 3
BATT:CYCLE {n} {SP} {NR1} {;}   NL}	TYPE4: Cycle = 1 - 2000, n = 1 - 3
BATT:CC {n} {SP} {NR2} {;}   NL}	TYPE5: Current, n = 0 - 9
BATT:DTIME {n} {SP} {NR2} {;}   NL}	TYPE5: Delta time T1 - T9: 0 - 6000 secs, n = 0 - 9
BATT:REPEAT {SP} {NR1} {;}   NL}	TYPE4 & TYPE5:Repeats = 0 - 9999
BATT:TEST {SP} {ON   OFF} {;}   NL}	ON:START TEST   OFF:STOP TEST TYPE1 & TYPE2: TEST END, AUTO ECHO "OK,XXXXX" XXXXX:AH TYPE3-5 TEST: END, AUTO ECHO "OK,XXXXX" XXXXX:DVM

Table 8-18: Battery Test Commands – Same as Short Form

## 8.6 Remote Control Command Descriptions

The remote control syntax of all available commands is described in the following sections. Supported commands are grouped in the following categories:

<b>Command Category</b>	<b>Description</b>
<b>SETTING</b>	Setting commands are used to program operating modes, sink values and built in test modes like SHORT, OPP and OCP.
<b>LIMIT</b>	Limit commands may be used to set expected upper and lower operating limits as they apply to a unit under test. These limit settings are used in conjunction with Go/No-go testing to indicate the load is sinking outside expected parameters.
<b>STATE</b>	State commands are used to query or clear status information from a load to determine its operating condition.
<b>SYSTEM</b>	System commands enable querying of load model number and configuration data, RS232 control on/off. They also support storing and saving load set-ups in non-volatile memory. (150 States)
<b>MEASUREMENTS</b>	Allows querying load measurement data.
<b>AUTO SEQUENCE</b>	Programming and execution of auto test sequences.
<b>BATTERY TEST</b>	Programming and execution of battery discharge test protocols.

### 8.6.1 SETTING Commands

#### RISE

**Command Syntax:** [PRESet:] RISE {SP} {NR2} {; | NL}  
[PRESet:] RISE ? {; | NL}

**Purpose:** Set and read the RISE SLEW-RATE.

**Description:**

1. The definition of the RISE SLEW-RATE is the rate of current change from a LOW level to a HIGH level when operating in dynamic mode. The settings of RISE and FALL are completely independent.
2. The RISE command must include a number value otherwise, the command will not be valid.
3. The least significant number is the fourth digit after the decimal point.
4. Should a value be entered that is higher than what is possible then the load will automatically set its maximum value according the load specifications.
5. The engineering unit is A/us.

#### FALL

**Command Syntax:** [PRESet:] FALL {SP} {; | NL}  
[PRESet:] FALL? {; | NL}

**Purpose:** Set and read the FALL SLEW-RATE.

**Description:**

1. The definition of the FALL SLEW-RATE is the rate of current change from a HIGH level to a LOW level when operating in dynamic mode. The settings of RISE and FALL are completely independent.
2. Should a value be entered that is higher than what is possible, the load will automatically set its maximum value according the load specification.
3. The engineering unit is A/us.

### PERI or PERD

**Command Syntax:** [PRESet:] PERI | PERD : HIGH | LOW {SP} {NR2} { ; | NL}  
[PRESet:] PERI | PERD : HIGH | LOW ? { ; | NL}

**Purpose:** Set and read the combined TLOW and THIGH of a DYNAMIC waveform.

**Description:**

1. The time period combines TLOW (time low) and THIGH (time high) sections of a DYNAMIC waveform.
2. The value of TLOW and THIGH has to be included the number of the decimal point; otherwise the command will not be available.
3. The least significant number is the fifth after the decimal point.
4. Should a value be entered that is higher than what is possible then the load will automatically set its maximum value according the load specifications.
5. The engineering unit is ms.

### LDONv

**Command Syntax:** [PRESet:] LDONv {SP} {NR2}{; | NL}  
[PRESet:] LDONv?{; | NL}

**Purpose:** Set and Read the voltage level at which the LOAD will switch ON.

**Description:** This command is used to set or query the voltage value at which the LOAD will automatically switch ON. The engineering unit is V.

### LDOFv

**Command Syntax:** [PRESet:] LDOFv {SP} {NR2} { ; | NL}  
[PRESet:] LDOFv?{; | NL}

**Purpose:** Set and read back the voltage level at which the LOAD will switch OFF.

**Description:** This command is used to set or query the voltage value at which the LOAD will automatically switch OFF. The engineering unit is V.

**CURR : HIGH | LOW**

**Command Syntax:** [PRESet:] CC | CURR : HIGH | LOW{SP} { NR2}{; | NL}  
[PRESet:] CC | CURR : HIGH | LOW? {; | NL}

**Purpose:** Set or read the HIGH or LOW current levels in Amps.

**Description:** This command is used to set or query the HIGH and LOW levels of load current allowed. These 2 current levels need to be used if a dynamic load waveform is used. It also allows the user to switch between two preset current levels.

1. The least significant number is the fifth digit after the decimal point.
2. The LOW level current value cannot be higher than the HIGH level.
3. Should a value be entered that is higher than what is possible then the load will automatically set the maximum value according the load specifications.
4. The engineering unit is A.

**CURR**

**Command Syntax:** [PRESet:] CC | CURR {SP} {NR2}{; | NL}  
[PRESet:] CC | CURR?{; | NL}

**Purpose:** Set or read the load current.

**Description:** This command is used to set or query the load current.

1. The least significant number is the fifth digit after the decimal point.
2. Should a value be entered that is higher than what is possible then the load will automatically set the maximum value according the load specifications.
3. The engineering unit is A.

**CP: {HIGH | LOW}**

**Command Syntax:** [PRESet:] CP:{ HIGH | LOW} {SP} { NR2} {; | NL}  
[PRESet:] CP:{ HIGH | LOW}? {; | NL}

**Purpose:** Set and read the operating power value in watts.

**Description:** This command is used to set or query the HIGH or LOW setting levels of load power. These 2 power levels need to be used should a dynamic load waveform be desired. It also allows the user to switch between two preset power levels.

1. The least significant number is the fifth digit after the decimal point.
2. The LOW level power value cannot be higher than the HIGH level.
3. Should a value be entered that is higher than what is possible then the load will automatically set its maximum value according the load specifications.
4. The engineering unit is W.

**CR | RES:{HIGH | LOW}**

**Command Syntax:** [PRESet:] CR | RES:{HIGH | LOW} {SP} {NR2} {; | NL}  
[PRESet:] CR | RES:{HIGH | LOW}? {; | NL}

**Purpose:** Set and read the HIGH or LOW resistance levels.

**Description:** This command is used to set or query the HIGH and LOW levels of load resistance. It allows the user to switch between two resistance levels.

1. The least significant number is the fifth digit after the decimal point.
2. The LOW level resistance value cannot be higher than the HIGH level.
3. Should a value be entered that is higher than what is possible then the load will automatically set its maximum value according the load specifications.
4. The engineering unit is  $\Omega$ .

**CR | RES**

**Command Syntax:** [PRESet:] CR | RES {SP} {NR2}{; | NL}  
[PRESet:] CR | RES? {; | NL}

**Purpose:** Set and read the resistance.

**Description:** This command is used to set or query the load resistance.

1. The least significant number is the fifth digit after the decimal point.
2. Should a value be entered that is higher than what is possible then the load will automatically set its maximum value according the load specifications.
3. The engineering unit is  $\Omega$ .

**CV: {HIGH | LOW}**

**Command Syntax:** [PRESet:] CV: {HIGH | LOW} {SP} {NR2}{; | NL}  
[PRESet:] CV: {HIGH | LOW}? {; | NL}

**Purpose:** Set and read the value of DC load voltage.

**Description:** This command is used to set or query the HIGH and LOW levels of load voltage. It allows the user to switch between two voltage levels.

1. The least significant number is the fifth digit after the decimal point.
2. The LOW level voltage value cannot be below the HIGH level.
3. Should a value be entered that is higher than what is possible then the load will automatically set its maximum value according the load specifications.
4. The engineering unit is V.

**CV**

**Command Syntax:** [PRESet:] CV {SP} {NR2}{; | NL}  
[PRESet:] CV? {; | NL}

**Purpose:** Set and read the value of DC load voltage.

**Description:** This command is used to set or query the load voltage.

1. The least significant number is the fifth digit after the decimal point.
2. Should a value be entered that is higher than what is possible then the load will automatically set its maximum value according the load specifications.
3. The engineering unit is V.

**OCP: START**

**Command Syntax:** [PRESet:] OCP:START {SP} {NR2}{; | NL}  
[PRESet:] OCP:START? {; | NL}

**Purpose:** Set and read the initial value of OCP test.

**Description:** This command is used to set or query the required initial value (I-START) of the OCP test.

**OCP: STEP**

**Command Syntax:** [PRESet:] OCP:STEP {SP} {NR2}{; | NL}  
[PRESet:] OCP:STEP? {; | NL}

**Purpose:** Set and read the increasing value of OCP test.

**Description:** This command is used to set or query the increment value (I-STEP) for the OCP test.

**OCP:STOP**

**Command Syntax:** [PRESet:] OCP:STOP {SP} {NR2} {; | NL}  
[PRESet:] OCP: STOP? {; | NL}

**Purpose:** Set and read the maximum value of OCP test.

**Description:** This command is used to set or query the maximum or end value (I-STOP) for the OCP test.

**VTH**

**Command Syntax:** [PRESet:] VTH {SP}{NR2}{; | NL}  
[PRESet:] VTH ? {; | NL}

**Purpose:** Set and read the value of the Threshold Voltage.

**Description:** This command is used to set or query the minimum threshold voltage for the OCP/OPP tests. If the measured voltage is below the threshold voltage and the OCP/OPP test started, the test will not run and an error will be flagged.

**OPP:START**

**Command Syntax:** [PRESet:] OPP:START {SP} {NR2} {; | NL}  
[PRESet:] OPP:START? {; | NL}

**Purpose:** Set and read the initial value of OPP test.

**Description:** This command is used to set or query setting the initial value (P-START) of the OPP test.

**OPP:STEP**

**Command Syntax:** [PRESet:] OPP:STEP {SP} {NR2} {;} | NL}  
[PRESet:] OPP:STEP? {;} | NL}

**Purpose:** Set and read the increasing value of OPP test.

**Description:** This command is used to set or query the power increments, which the OPP test will follow between the P-START and P-STOP values.

**OPP:STOP**

**Command Syntax:** [PRESet:] OPP:STOP {SP} {NR2} {;} | NL}  
[PRESet:] OPP:STOP? {;} | NL}

**Purpose:** Set and read the maximum value of OPP test.

**Description:** This command is used to set or query the maximum power value (P-STOP) of the OPP test.

**TCONFIG**

**Command Syntax:** [PRESet:] TONFIG {NORMAL | OCP | OVP | OPP | SHORT} {;} | NL}  
[PRESet:] TONFIG ? {;} | NL}

**Purpose:** Set or query the function mode of dynamic test.

**Description:** There are five options for this command. Those are NORMAL mode, OCP Test, OVP Test, OPP Test and SHORT Mode Test.

**STIME**

**Command Syntax:** [PRESet:] STIME {SP} {NR2}{;} | NL}  
[PRESet:] STIME? {;} | NL}

**Purpose:** Set and read time of the short-circuit test.

**Description:** This command is used to set the short-circuit test time. If the time is set to zero, there is no time limit. In other words, a continuous short circuit test will be implemented. If a non-zero value is entered, this is the short circuit duration test time in milliseconds (msec).

### OCP

**Command Syntax:** OCP? {; | NL}

**Purpose:** Query the OCP test current.

**Description:** This command is used to query the OCP current measured in the OCP test.

### OPP

**Command Syntax:** OPP? {; | NL}

**Purpose:** Query the OPP test power level in watt.

**Description:** This command is used to query the OPP power for the OPP test.

### 8.6.2 LIMIT Commands

LIMIT commands are used to set high and low operating limits that can be used in conjunction with the GO/NOGO (NG) function to signal that the load is sinking outside the expected parameters.

#### [LIMit:]CURRent:{HIGH | LOW} or IH | IL

**Command Syntax:** [LIMit:]CURRent:{HIGH | LOW} {SP} { NR2 } {;} |NL}  
 [LIMit:]CURRent:{HIGH | LOW}? {;} |NL}  
 [IH | IL]{SP}{ NR2 } {;} |NL}  
 [IH | IL]? {;} |NL}

**Purpose:** Set or query the HIGH / LOW load current limits when operating in CC or CR modes.

**Description:** This command is used to set or query two current LIMIT values. Operation outside these LIMIT values will cause a No Good (NG) signal to be generated.

1. The LOW level cannot be higher than the HIGH level.
2. If the current taken by the load falls below the LOW limit then a No Good (NG) signal is available.
3. If the current rises above the HIGH limit then the NG signal is available.
4. If the current stays between HIGH and LOW LIMIT levels the NG signal will not be sent.

#### [LIMit:]POWer:{HIGH | LOW} or WH | WL

**Command Syntax:** [LIMit:]POWer:{HIGH | LOW}{SP}{ NR2 } {;} |NL}  
 [LIMit:]POWer:{HIGH | LOW}? {;} |NL}  
 [WH | WL]{SP}{ NR2 } {;} |NL}  
 [WH | WL]? {;} |NL}

**Purpose:** Set or query the HIGH / LOW load power limits when operating in CP or CR modes.

**Description:** This command is used to set two power LIMIT values. Operation outside these LIMIT values will cause a NG signal to be generated.

1. The LOW level cannot be higher than the HIGH level.
2. If the power taken by the load falls below the LOW limit then a No Good (NG) signal is available.
3. If the power rises above the HIGH limit then the NG signal is available.
4. If the power stays between HIGH and LOW LIMIT levels the NG signal will not be sent.

**[LIMit:]VOLTage:{HIGH | LOW} or VH | VL**

**Command Syntax:** [LIMit:]VOLTage:{HIGH | LOW} {SP} { NR2 }{;}|NL}  
 [LIMit:]VOLTage:{ HIGH | LOW}? {;}|NL}  
 [VH | VL] {SP} { NR2 }{;}|NL}  
 [VH | VL]? {;}|NL}

**Purpose:** Set or query the HIGH / LOW limits of voltage present at the load terminals.

**Description:** This command is used to set two voltage LIMIT values. Operation outside these LIMIT values will cause a NG signal to be generated.

1. The LOW level cannot be higher than the HIGH level.
2. If the voltage at the load input falls below the LOW limit then a No Good (NG) signal is available.
3. If the voltage rises above the HIGH limit then the NG signal is available.
4. If the current stays between HIGH and LOW LIMIT levels, the NG signal will not be sent.

**[LIMit : ] SVH | SVL**

**Command Syntax:** [LIMit:] {SVH | SVL} {SP} {NR2}{;}|NL}  
 [LIMit:] {SVH | SVL}? {;}|NL}

**Purpose:** Set or query the upper and lower voltage levels during for short test.

**Description:** This command is used to set two voltage LIMIT values. If during the short test the voltage is outside these LIMIT values, a NG signal will be generated.

1. The LOW level cannot be higher than the HIGH level.
2. If the voltage at the load input falls below the LOW limit then a No Good (NG) signal is available.
3. If the voltage rises above the HIGH limit then the NG signal is given.
4. If the current stays between HIGH and LOW LIMIT levels, the NG signal will not be sent.

### 8.6.3 STATE Commands

STATE commands can be used to set or query the actual operating status of the electronic load at any time.

#### [STATe:] LOAD {SP} {ON | OFF}

**Command Syntax:** [STATe:] LOAD {SP} {ON | OFF}; | NL  
[STATe:] LOAD? { }; | NL

**Purpose:** Read LOAD ON or OFF status.

**Description:** This command is used to see if the Load is ON or OFF. 0 = Load OFF, 1 = Load ON.

#### [STATe:] MODE {SP} {CC | CR | CV | CP}

**Command Syntax:** [STATe:] MODE {SP} {CC | CR | CV | CP}; | NL  
[STATe:] MODE? { }; | NL

**Purpose:** Set and read the operating mode of LOAD.

**Description:** The return value is 0 | 1 | 2 | 3 which corresponds to the operating mode that the load is in. i.e. CC | CR | CV | CP.

Mode:	CC	CR	CV	CP
Value:	(0)	(1)	(2)	(3)
Supported	V	V	V	V

#### [STATe:] SHORt {SP} {ON | OFF}

**Command Syntax:** [STATe:] SHORt {SP} {ON | OFF}; | NL  
[STATe:] SHORt? { }; | NL

**Purpose:** Reads back whether the short circuit test is active or not.

**Description:** 0 = short circuit test active, 1 = short circuit test inactive

#### [STATe:] PRESet {SP} {ON | OFF}

**Command Syntax:** [STATe:] PRESet {SP} {ON | OFF}; | NL  
[STATe:] PRESet? { }; | NL

**Purpose:** Reads back whether load is in preset mode.

**Description:** This command is used to check if the load is in preset mode. 0 = Preset mode OFF, 1 = Preset mode ON

**[STATE:] SENSE{SP} {ON | OFF | AUTO}**

**Command Syntax:** [STATE:] SENSE {SP}{ON | OFF | AUTO }{; | NL}  
[STATE:] SENSE? {; | NL}

**Purpose:** Reads back whether the sense function is ON or OFF.

**Description:** 0 = Sense OFF or Sense AUTO  
1 = Sense ON

**[STATE:] LEVEL {SP} {HIGH | LOW} or LEV {SP} {HIGH | LOW}**

**Command Syntax:** [STATE:] LEVEL {SP} {HIGH | LOW }{; | NL}  
[STATE:] LEVEL? {; | NL}  
[STATE:] LEV {SP} {HIGH | LOW}{; | NL}  
[STATE:] LEV? {; | NL}

**Purpose:** Reads back whether the load is operating at its LOW or HIGH LEVEL.

**Description:** In CC, CR, CV or CP operating modes the user can set two LEVELS of load current, resistance, voltage or power. The load will read back which level it is at:  
0 = Load operating at low level  
1 = Load operating at high level

**[STATE:] DYNAMIC {SP} {ON | OFF}**

**Command Syntax:** [STATE:] DYNAMIC {SP} {ON | OFF}{; | NL}  
[STATE:] DYNAMIC? {; | NL}

**Purpose:** Reads back whether the load is operating in STATIC or DYNAMIC mode.

**Description:** 0 = Dynamic operation  
1 = Static Operation

**[STATE:] CLR**

**Command Syntax:** [STATE:] CLR {; | NL}

**Purpose:** Clears the error flag.

**Description:** This command is used for clearing the contents of the PROT and ERR registers. After execution, the contents of these two registers will be "0".

**[STATe:] ERROr**

**Command Syntax:** [STATe:] ERROr? {; | NL}

**Purpose:** Query if there are any errors flagged in the module.

**Description:** ERR? : Read the register of ERR status. Table 22 shows the corresponding number of ERR status.  
Use command CLR to clear the register of ERR status to be "0"

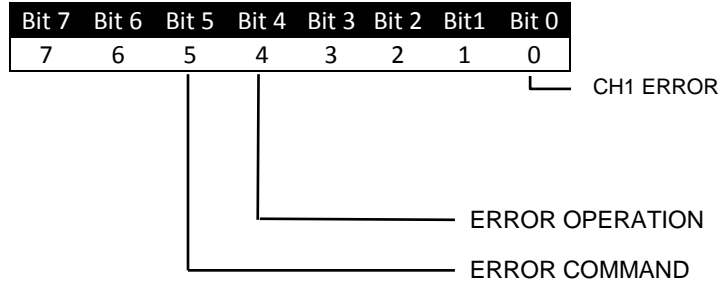

BIT ID	BIT VALUE	REMARK
bit 0-3	0 = Off, 1 = Triggered	CH1 error
bit 4	0 = Off, 1 = Triggered	Operation error
bit 5	0 = Off, 1 = Triggered	Command error (e.g. syntax error)

Table 8-19: Error Register Bits

**[STATE:] NG? {; | NL}**

**Command Syntax:** [STATE:] NG? {; | NL}

**Purpose:** Query if the NG flag is displayed on this module.

**Description:** This command queries the NG status. If the response is "0", the LED of NG (NO GOOD) will be off. If the response is "1", the LED will be lit, showing that the NG flag is present.

**[STATE:] PROTECT? {; | NL}**

**Command Syntax:** [STATE:] PROTECT? {; | NL}

**Purpose:** Query the state of the protection register on this module.

**Description:** PROT? requests the status of the units protection register.  
Use the command "CLR" to clear the register of PROT status to "0".

Bit 7	Bit 6	Bit 5	Bit 4	Bit 3	Bit 2	Bit 1	Bit 0
7	6	5	4	3	2	1	0

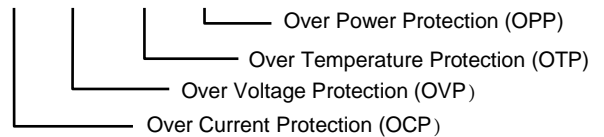

BIT ID	BIT VALUE	REMARK
bit 0	0 = Off, 1 = Triggered	Over Power Protection (OPP)
bit 1	0 = Off, 1 = Triggered	Over Temperature Protection (OTP)
bit 2	0 = Off, 1 = Triggered	Over Voltage Protection (OVP)
bit 3	0 = Off, 1 = Triggered	Over Current Protection (OCP)

Table 8-20: Protection Status Register Bits

**[STAtE:] CCR {AUTO | R2}**

**Command Syntax:** [STAtE:] CCR {AUTO | R2} {; | NL}

**Purpose:** This command sets the CC MODE RANGE, forcing RANGE II operation if required.

**Description:** Switches the unit between AUTO RANGE and RANGE II. AUTO RANGE will allow the unit to move to a more precise range at low currents, while forcing the unit to remain in RANGE II keeps the range consistent regardless of the current level.

**[STAtE:] POLAR {POS | NEG}**

**Command Syntax:** [STAtE:] POLAR {POS | NEG} {; | NL}

**Purpose:** Sets the polarity displayed by the voltage meter.

**Description:** The voltage read-out can be set to POS for positive, and NEG for negative polarity display.

**[STAtE:] START**

**Command Syntax:** [STAtE:]START {; | NL}

**Purpose:** Set for load to begin the test.

**Description:** Begins the test, according to the TEST CONFIG (TCONFIG). The load will start the test based on the items and parameters stored.

**[STAtE:] STOP**

**Command Syntax:** [STAtE:]STOP {; | NL}

**Purpose:** Stops a test, if one is in progress.

#### 8.6.4 SYSTEM Commands

SYSTEM commands allow the user to read the model number of the load and turn RS232 remote control ON and OFF. Commands are also available for storing and retrieving load set-ups saved in the memory of the load. The load has 150 separate memory locations.

All 5VP Series Cabinet Models	
STATE (m)	150
Total States / Mem. Locations	150

#### [SYStem:] RECall {SP} {m} [, n]

**Command Syntax:** [SYStem:] RECall {SP} {m} {; | NL}

**Purpose:** Recalls the load set-up, which has been previously saved in memory.

**Description:** This command is for recalling the procedure stored in a specified memory location where:

m = STATE, 1 through 150

**Example:**

RECALL 25	Recalls the load set up saved in the STATE 25 of the memory.
REC 3	Recalls the load set up from the 3rd memory STATE.

#### [SYStem:] STORe {SP} {m}[, n]

**Command Syntax:** [SYStem:] STORe {SP} {m} {; | NL}

**Purpose:** Saves the load's status to the unit's memory.

**Description:** This command is for saving the current set up to a specified memory location where:

m = STATE, 1 through 150

**For example:**

STORE 25	Saves the status of the load to the 25th STATE of the memory.
STOR 3	Saves the load setup to the 3rd memory STATE.

[SYStem:] NAME?

**Command Syntax:** [SYStem:] NAME? {; | NL}

**Purpose:** Returns the model number of the load.

**Description:** This command is for reading the model number of the load. The model number length shown on the LDC at power up is limited to 5 characters but the MODE? Command returns the complete model number string. The model number will be returned as per Table 8-21.

APS-Model	Return Value	APS-Model	Return Value
<b>60 V Models</b>		<b>1000 V Models</b>	
5VP05-100	APS_5VP05-100	5VP50-21	APS_5VP50-21
5VP10-100	APS_5VP10-100	5VP60-24	APS_5VP60-24
5VP15-100	APS_5VP15-100	5VP05-05	APS_5VP05-05
5VP20-100	APS_5VP20-100	5VP10-10	APS_5VP10-10
5VP25-100	APS_5VP25-100	5VP15-15	APS_5VP15-15
5VP30-100	APS_5VP30-100	5VP20-20	APS_5VP20-20
<b>600 V Models</b>		5VP25-25	APS_5VP25-25
5VP05-16	APS_5VP05-16	5VP30-30	APS_5VP30-30
5VP10-32	APS_5VP10-32	5VP35-35	APS_5VP35-35
5VP15-48	APS_5VP15-48	5VP40-40	APS_5VP40-40
5VP20-64	APS_5VP20-64	5VP50-50	APS_5VP50-50
5VP25-80	APS_5VP25-80	5VP60-60	APS_5VP60-60
5VP30-96	APS_5VP30-96		
5VP40-128	APS_5VP40-128		

Table 8-21: 5VP Series Cabinet Load Model Name Return Values

**[SYSTem:] \*RST**

**Command Syntax:** [SYSTem:] \*RST {; | NL}

**Purpose:** Load reset.

**Description:** This command resets the load to its default state.

**[SYSTem:] REMOTE**

**Command Syntax:** [SYSTem:] REMOTE {; | NL}

**Purpose:** Command to enter REMOTE status (only for RS232, USB or LAN).

**Description:** This command is for enabling control of the unit via RS232, USB or LAN.

**[SYSTem:] LOCAL**

**Command Syntax:** [SYSTem:] LOCAL {; | NL}

**Purpose:** Command to exit the REMOTE status (only for RS232)

**Description:** This command closes the RS232 control interface.

**SYNC:LOAD {SP} {ON | OFF}**

**Command Syntax:** SYNC:LOAD {SP} {ON | OFF} {; | NL}

**Purpose:** Command to enable or disable all electronics loads in the mainframe at the same time.

**Example:** SYNC:LOAD ON  
SYNC:LOAD OFF

### 8.6.5 MEASUREMENT Commands

Measurement commands allow measurement data for each module to be retrieved.

#### **MEASure:CURRent?**

**Command Syntax:** MEASure:CURRent? {; | NL}

**Purpose:** Measures the load current.

**Description:** Reads the current meter data. The engineering unit is Ampere (A).

#### **MEASure:VOLtage?**

**Command Syntax:** MEASure:VOLtage? {; | NL}

**Purpose:** Measures the load voltage.

**Description:** Reads the voltmeter data. The engineering unit is Voltage (V).

#### **MEASure:POWer?**

**Command Syntax:** MEASure:POWer? {; | NL}

**Purpose:** Reads the power being absorbed by the load.

**Description:** Reads the power meter data. The engineering unit is Watt (W).

### 8.6.1 AUTO SEQUENCE Commands

Auto sequence commands enable the programming and execution of auto test sequences.

#### **FILE {SP} {n} {; | NL}**

**Command Syntax:** FILE {SP} {n} {; | NL}

**Purpose:** Select auto sequence memory F1 through F9

**Description:** Up to nine auto sequences can be programmed and retained in non-volatile memory. This command selects the active auto test sequence. Range is 1 through 9.

#### **STEP {SP} {n} {; | NL}**

**Command Syntax:** STEP {SP} {n} {; | NL}

**Purpose:** Select auto sequence step number

**Description:** Each auto test sequence program can have up to 16 steps. This command selects the step to be programmed. Range is 1 through 16.

#### **TOTSTEP {SP} {n} {; | NL}**

**Command Syntax:** TOTSTEP {SP} {n} {; | NL}

**Purpose:** Sets the total number of steps for the selected auto test sequence Fx.

**Description:** Set to number of steps required. Range is 1 through 16.

#### **SB {SP} {m} {; | NL}**

**Command Syntax:** SB {SP} {m} {; | NL}

**Purpose:** Selects the load setup state number for test step.

**Description:** Each step can recall a load setup (state) from non-volatile memory. Available range for m is 1 through 150.

#### **T1 {SP} {NR2} {; | NL}**

**Command Syntax:** T1 {SP} {NR2} {; | NL}

**Purpose:** T1 time delay for selected step.

**Description:** Sets value of T1. Available range is 0.1 sec to 9.9 sec.

**T2 {SP} {NR2} {;} | NL}****Command Syntax:** T2 {SP} {NR2} {;} | NL}**Purpose:** T2 time delay for selected step.**Description:** Sets value of T2. Available range is 0.0 sec to 9.9 sec.**SAVE {;} | NL}****Command Syntax:** SAVE {;} | NL}**Purpose:** Save selected auto test sequence program (Fx).**Description:** Saves selected program (F1 through F9) to non-volatile memory.**REPEAT {SP} {n} {;} | NL}****Command Syntax:** REPEAT {SP} {n} {;} | NL}**Purpose:** Sets repeat counts for selected test step.**Description:** Step repeat count. Available range is for n is 0 through 9999.**RUN {SP} {F} {n} {;} | NL}****Command Syntax:** RUN {SP} {F} {n} {;} | NL}**Purpose:** Execute auto sequence program Fx.**Description:** Starts program execution of selected Fx auto test sequence. At the end of the test, returns:  
"PASS" or "FAIL:XX" where XX is first failed (NoGo) step.

### 8.6.2 BATTERY TEST Commands

The battery commands subsystem allows programming and execution of one of five embedded battery discharge protocols. Refer to section 3.4, “Battery Discharge Protocols” on page 23 for background information on the five battery test modes available.

#### **BATT:TYPE {SP} {n} {;} | NL}**

**Command Syntax:** BATT:TYPE {SP} {n} {;} | NL}

**Purpose:** Select Battery Test Protocol

**Description:** This command selects the type of battery test by number. Available test protocols are numbered from 1 through 5.  
Note: TYPE 1 through 3 can be operated from either front panel or remote control interfaces. TYPE4 and TYPE5 can only be operated via the remote control interface. See section 3.4, “Battery Discharge Protocols” on page 23 for details on each battery test type.

#### **BATT:BATT {SP} {NR1} {;} | NL}**

**Command Syntax:** BATT:BATT {SP} {NR1} {;} | NL}

**Purpose:** Sets the battery voltage for each battery type.

**Description:** Sets the battery voltage for TYPE1 through TYPE3.

#### **BATT:UVP {SP} {NR2} {;} | NL}**

**Command Syntax:** BATT:UVP {SP} {NR2} {;} | NL}

**Purpose:** Set battery under voltage protection level.

**Description:** Sets the lowest acceptable battery voltage that the battery can be discharged to. If the battery voltage drops below this level, the battery test is aborted or stopped. Range is determined by load model used.

#### **BATT:TIME {SP} {NR1} {;} | NL}**

**Command Syntax:** BATT:TIME {SP} {NR1} {;} | NL}

**Purpose:** Sets battery discharge time.

**Description:** The battery discharge time can be set for TYPE3. Available range is 1 through 99999 secs.

**BATT:STEP {SP} {n} {; | NL}****Command Syntax:** BATT:STEP {SP} {n} {; | NL}**Purpose:** Sets the number of steps for battery test TYPE4 or TYPE5**Description:** The number of steps available depends on the TYPE selected. For TYPE4, n = 1 to 3, for TYPE5, n = 1 to 9.**BATT:CCH {n} {SP} {NR2} {; | NL}****Command Syntax:** BATT:CCH {n} {SP} {NR2} {; | NL}**Purpose:** Sets the high current discharge levels for battery test TYPE4**Description:** Three high level CC discharge current settings are available for TYPE4 tests (n = 1 to 3). Available current range is a function of the load model.**BATT:CCL {n} {SP} {NR2} {; | NL}****Command Syntax:** BATT:CCL {n} {SP} {NR2} {; | NL}**Purpose:** Sets the low current discharge levels for battery test TYPE4**Description:** Three low level CC discharge current settings are available for TYPE4 tests (n = 1 to 3). Available current range is a function of the load model.**BATT:TH {n} {SP} {NR2} {; | NL}****Command Syntax:** BATT:TH {n} {SP} {NR2} {; | NL}**Purpose:** Sets TYPE4 or TYPE5 test Thigh values.**Description:** Thigh determines the time for which the battery will be discharged using the lower current level for each cycle. There are 3 Thigh settings (n = 1 to 3). Time interval range is T = 0 to 99999 secs.**BATT:TL {n} {SP} {NR2} {; | NL}****Command Syntax:** BATT:TL {n} {SP} {NR2} {; | NL}**Purpose:** Sets TYPE4 or TYPE5 test Tlow values.**Description:** Tlow determines the time for which the battery will be discharged using the lower current level for each cycle. There are 3 Tlow settings (n = 1 to 3). Time interval range is T = 0 to 99999 secs.

**BATT:CYCLE {n} {SP} {NR1} {;} | NL}****Command Syntax:** BATT:CYCLE {n} {SP} {NR1} {;} | NL}**Purpose:** Sets the number of cycles for battery TYPE4 or TYPE5.**Description:** There are 3 CYCLE settings (n = 1 to 3). Available setting range is 1 to 2000.**BATT:CC {n} {SP} {NR2} {;} | NL}****Command Syntax:** BATT:CC {n} {SP} {NR2} {;} | NL}**Purpose:** Sets the current discharge levels for battery test TYPE5.**Description:** There are ten CC settings for TYPE5, CC0 through CC9 (n = 0 to 9). The current slew rate between steps is determined by the change in current ( $\Delta C$ ) and the delta time ( $\Delta T$ ).**BATT:DTIME {n} {SP} {NR2} {;} | NL}****Command Syntax:** BATT:DTIME {n} {SP} {NR2} {;} | NL}**Purpose:** Sets the delta times for battery test TYPE5.**Description:** There are nine  $\Delta T$  settings for TYPE5, T1 through T9 (n = 1 to 9). The current slew rate between steps is determined by the change in current ( $\Delta C$ ) and the delta time ( $\Delta T$ ). Slew =  $\Delta C / \Delta T$ .**BATT:REPEAT {SP} {NR1} {;} | NL}****Command Syntax:** BATT:REPEAT {SP} {NR1} {;} | NL}**Purpose:** Sets the number of repeats for battery tests TYPE4 and TYPE5.**Description:** The repeat value determines how often each step is repeated. Available range is 0 to 9999.**BATT:TEST {SP} {ON | OFF} {;} | NL}****Command Syntax:** BATT:TEST {SP} {ON | OFF} {;} | NL}**Purpose:** Turns selected battery test on (start) or off (stop).**Description:** The result for each battery test type depends on the type number:  
TYPE1 & TYPE2: Returns "OK,XXXXX" where XXXXX is the total energy in Ampere Hours discharged during the test.  
TYPE3, TYPE4 & TYPE5: Returns "OK,XXXXX" where XXXXX is the battery voltage at the end of the test.

## 8.7 IEEE488.2 Common Commands

The following IEEE488.2 common commands (a.k.a. star commands) are supported by the load.

### 8.7.1 \*IDN?

<b>Command Syntax:</b>	<b>*IDN? {;   NL}</b>
<b>Purpose:</b>	Returns the load Identity string.
<b>Description:</b>	This command is similar to the MODEL command but returns the response in a SCPI format. The response contains several four fields separated by a comma.
<b>Query response:</b>	Manufacturer, load model number and controller firmware revision.
<b>Example:</b>	APS,5VP40-40,1.0

### 8.7.2 \*RST

<b>Command Syntax:</b>	<b>*RST {;   NL}</b>
<b>Purpose:</b>	Reset instrument
<b>Description:</b>	The *RST command (reset) has the same effect as an IEEE-488 Device Clear bus command but can be used over the RS232C interface as well. This command resets the load to its power on default state.

## 9 USB Driver Installation

### 9.1 Overview

The load may be equipped with a USB interface. To communicate with this interface, a USB device driver is required on a Windows PC. This appendix describes the driver installation process for the PL-2303 USB to Serial Driver. Once installed, the USB port will appear as a COM port to the Windows Operating System.

### 9.2 USB Driver Installation

To install the USB device driver, proceed as follows:

1. Insert the supplied CD ROM into a CD Rom drive.
2. If configured for auto-start, the driver installation program will launch. If not, run “USB\SETUP\PL-2303 Driver Installer.exe” from the CD Rom drive.
3. This will open the first installation wizard screen.



4. Follow the on-screen prompts.



5. After the installation completes, open the Windows Control Panel from the Start menu and select “Device Manager”.
6. In the Device Manger Listing, locate the “Ports (COM & LPT)” entry

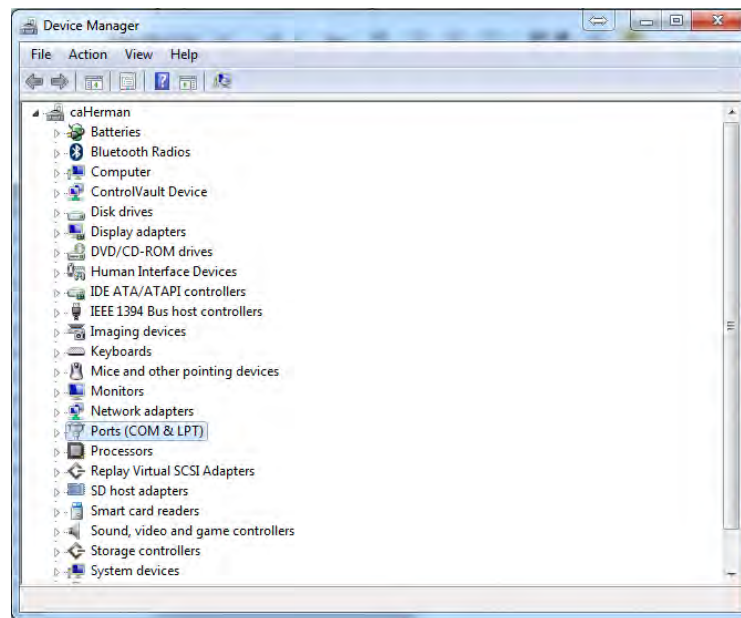

7. One of the entries should show “USB to Serial Port (COMx) with x any value higher than 2.
8. Note the Com port number at which the USB device is located. Right click on this Com port and select “Properties”.
9. In the Properties dialog box, select “Port Settings”.

10. Select the relevant COM port and set Bit per second (baud rate) to “115200” and Flow control “Hardware”.

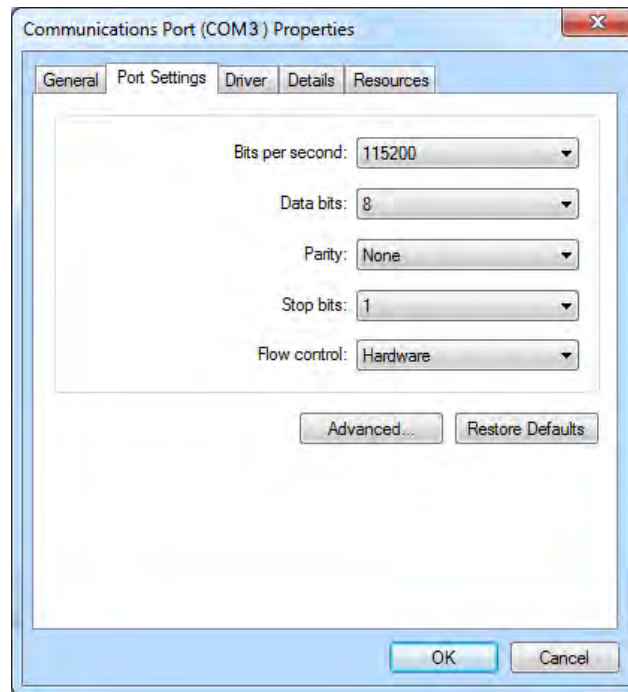

11. Connect the load to the PC using a suitable USB cable. (not supplied with the load).
12. You should now be able to communicate with the load through COMn.

## 10 LAN Driver Installation

### 10.1 Overview

The load may be equipped with a LAN (Ethernet) interface. To communicate with this interface, an Ethernet Manager Utility program is supplied with the LAN interface. This appendix describes the use of this utility to establish a network connection with the load under Windows.

### 10.2 Introduction

To establish an Ethernet connection between a PC on your network and the load, proceed as follows:

1. Connect AC power and the network (LAN) CAT5 cable to the load.
2. Connect the other side of the network cable to an existing Ethernet network.
3. After inserting the driver CD-ROM, run LAN\ETM.EXE from the CD.
4. The Ethernet Manager screen will be displayed as shown below. If the Ethernet Manager window does not appear, press F5 to search again (refresh), and check the LAN connections if necessary.

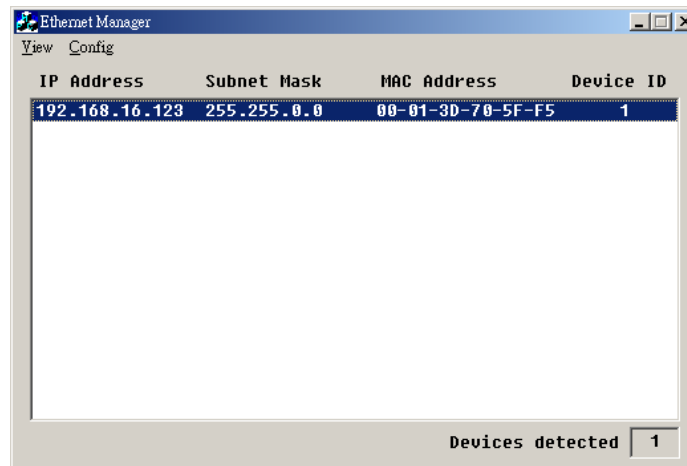

5. The connected unit will appear on the list, click it to set the IP Address and Subnet Mask as shown in the figure below.

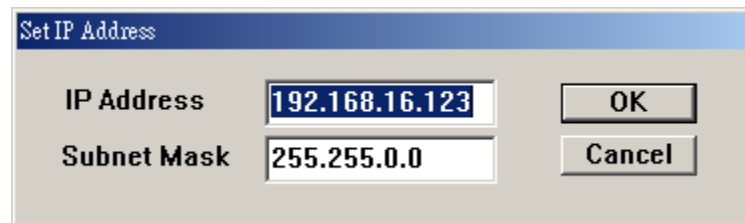

6. At this point, the Controller Setup page should be accessible, once everything is set correctly. This allows greater control over the communications interface.

Controller Setup				
IP Address	192.186.16.128			
Subnet mask	255.255.255.0			
Gateway address	0.0.0.0			
Network link speed	Auto			
DHCP client	Enable			
Socket port of HTTP setup	80			
Socket port of serial I/O	4001	TCP Server		
Socket port of digital I/O	5001	TCP Server		
Destination IP address / socket port (TCP client and UDP) Connection	0.0.0.0	0	Auto	
TCP socket inactive timeout (minutes)	0			
Serial I/O settings (baud rate, parity, data bits, stop bits)	115200	N	8	1
Interface of serial I/O	RS 232 (RTS/CTS)			
Packet mode of serial input	Disable			
Device ID	1			
Report device ID when connected	Disable			
Setup password				
UPDATE				

7. Insert the following into the controller set up screen:

IP Address: as recommended according to your network  
 Subnet Mask: as recommended according to your network  
 Gateway Address: as recommended according to your network  
 Network link speed: Auto  
 DHCP client: Enable  
 Socket port of HTTP setup: 80  
 Socket port of serial I/O: 4001, TCP Server  
 Socket port of digital I/O: 5001, TCP Server  
 Destination IP address / socket port (TCP client and UDP) Connection: Auto  
 TCP socket inactive timeout(minutes) : Set the network disconnection after N minutes, set 0 minutes will work forever.  
 Serial I/O settings (baud rate, parity, data, bits, stop bits): 115200, N, 8, 1  
 Interface of serial I/O: RS 232 (RTS/CTS)  
 Packet mode of serial input: Disable  
 Device ID : 5  
 Report device ID when connected : Auto  
 Setup password: Not required

If you experience difficulties establishing a connection, contact your network administrator for assistance. Network security setting may prevent you from connecting properly.

## 11 Auto Sequence Programming Examples

### 11.1 Overview

An auto-sequence allows the user to step through previously saved set-ups stored in the mainframe's memory. Up to nine auto-sequences can be saved. Each auto-sequence can consist of up to sixteen steps. There are two modes available for the auto-sequence function. These are **edit mode** - to set up an auto-sequence and **test mode** - to recall and start an auto-sequence execution. Refer also to section 6.2.6.5, "SEQ - AUTO SEQUENCE – EDIT MODE" on page 112 and section 6.2.6.1, "SEQ - AUTO SEQUENCE – TEST MODE" on page 116.

### 11.2 Edit Mode

To set up a new auto-sequence using the Edit mode, proceed as follows:

1. Set-up all load parameters such as the operating mode, along with sink values and the LOAD ON/OFF status. Configuration and limit settings can also be set and the NG ON function may be selected as part of the setup.
2. Press the STORE key to store the set up in one of the memory locations.
3. Repeat the previous steps as needed to create additional load set-ups and saved them to separate memory locations using the "**Shift-Store**" key.
4. Once the required number of load setups has been saved enter the auto sequence mode by pressing the "**Shift-SEQ**" key.
5. With the "**Shift-SEQ**" button lit, the auto-sequence identity (F1 to F9) can be selected using the shuttle.
6. Now select the first memory location. This will become the first step of the AUTO-SEQUENCE.
7. Using the arrow keys or shuttle, set the test time for that step of the auto-sequence.
8. Press "**Enter**" key to save the time setting and move onto the next step of the auto-sequence.
9. Repeat steps 6 through 8 to as needed to enter up to 150 steps to form the auto-sequence.
10. Once the desired number of steps have been set, press the "**Enter**" key.
11. The LCD will show REP (repetitions).
12. Use the arrow keys or shuttle to set the number of auto-sequence repetitions.
13. Press "**Enter**" to confirm the sequence edit.

This completes the programming sequence.

### 11.3 Test Mode

To execute a previously stored auto-test sequence, proceed as follows:

1. Press the “**Shift-SEQ**” key on the front panel to enter the TEST mode.
2. Use the keypad or shuttle to select the previously saved auto-sequence F1 through F9.
3. Press “**Start/Stop**” key to start the auto-sequence.
4. The LCD shows “PASS” or “FAIL” after testing.  
If limits and the NG functions have been set and a test step fails, the mainframe LCD display will flash “NG”. The user must then press “**Enter**” to continue the auto-sequence execution or “**Shift-Exit**” to abort the auto-sequence.
5. Press “**Start/Stop**” at any time to abort an auto-test sequence.

### 11.4 AUTO TEST SEQUENCE Example

In this example, we will create a program based on following illustration of a varying current over time. A total of eight sequence steps will be needed to implement this sequence. The program executes steps 1 to 8 in sequence.

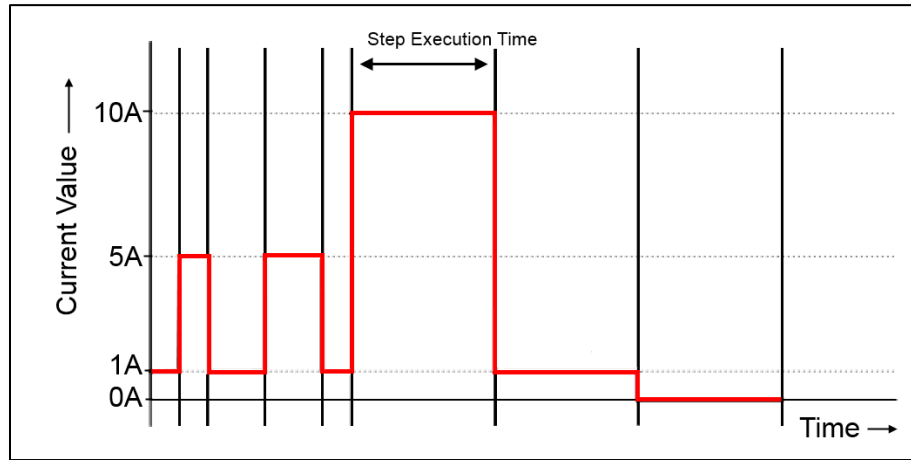

*Figure 11-1 Auto-Test Sequence Example Illustration*

The desired current levels and durations are shown in the table below.

Auto-sequence Step number	Memory STATE	Current Value	Execution Time
1	1	1.0 Adc	200 ms
2	2	5.0 Adc	200 ms
3	3	1.0 Adc	400 ms
4	4	5.0 Adc	400 ms
5	5	1.0 Adc	200 ms
6	6	10.0 Adc	1000 ms
7	7	1.0 Adc	1000 ms
8	8	0.0 Adc	1000 ms

*Table 11-1: Auto-Test Sequence Example Values*

The current test waveform can be checked on an oscilloscope as shown here - assuming that the DC source can supply the programmed load currents.

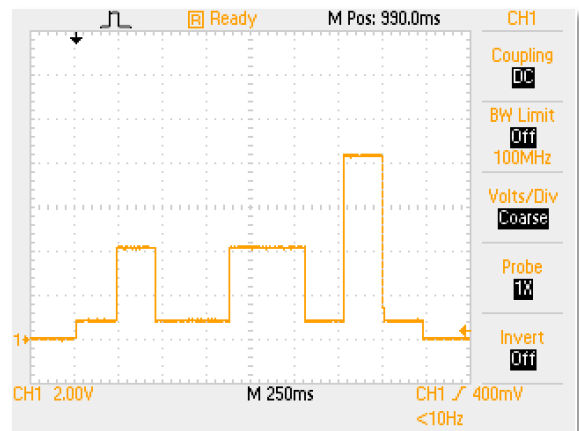

## 12 Short Circuit, OPP and OCP Test Examples

### 12.1 Overview

This appendix provides examples on how to program the built-in test modes of the 5 Series loads. These tests allow commonly used functional testing of power supplies with minimal programming effort. The following front panel test examples may prove useful.

### 12.2 OCP Test Example

Following setting steps are required to set up and execute over current protection test mode.

Press the “Limit” key to set the upper and lower current limit for the EUT during over current conditions. The “I\_Hi” limit screen will be displayed. Set I\_Hi to 8A as shown.

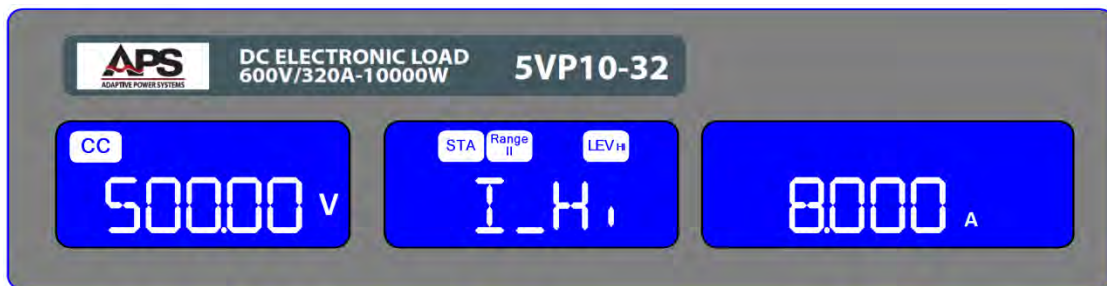

Press the “Limit” key again to set the lower current limit for the EUT during over current conditions. The “I\_Lo” limit screen will be displayed. Set I\_Lo to 0A as shown.



We are now ready to proceed to the OCP test mode. Press the “OCP” key to proceed to the OCP setup screen. “OCP-PRESS-START” will be displayed. Press the DOWN cursor key to enter the EDIT mode.



Set the starting current “ISTAR” to 0A as shown below.



Press the DOWN cursor key to proceed to the “ISTEP” setup screen and enter 0.01A. The current will be increased in 10mA steps.



Press the DOWN cursor key to proceed to the “ISTOP” setup screen and enter 5A as the final current test level. Once this setting is reached, the OCP test will end.



Press the DOWN cursor key to proceed to the “VTH” voltage threshold setup screen and enter 6.0Vdc as the voltage trip level as shown below.



This completes the OCP test setup. We are now ready to execute the test. Press the red “Start/Stop” button to enter TEST mode.

The test will run displaying the test current at each step. During the OCP test, the load monitors the EUT voltage to see if it drops below the VTH voltage threshold level.

OPC test screens during test execution are shown here:

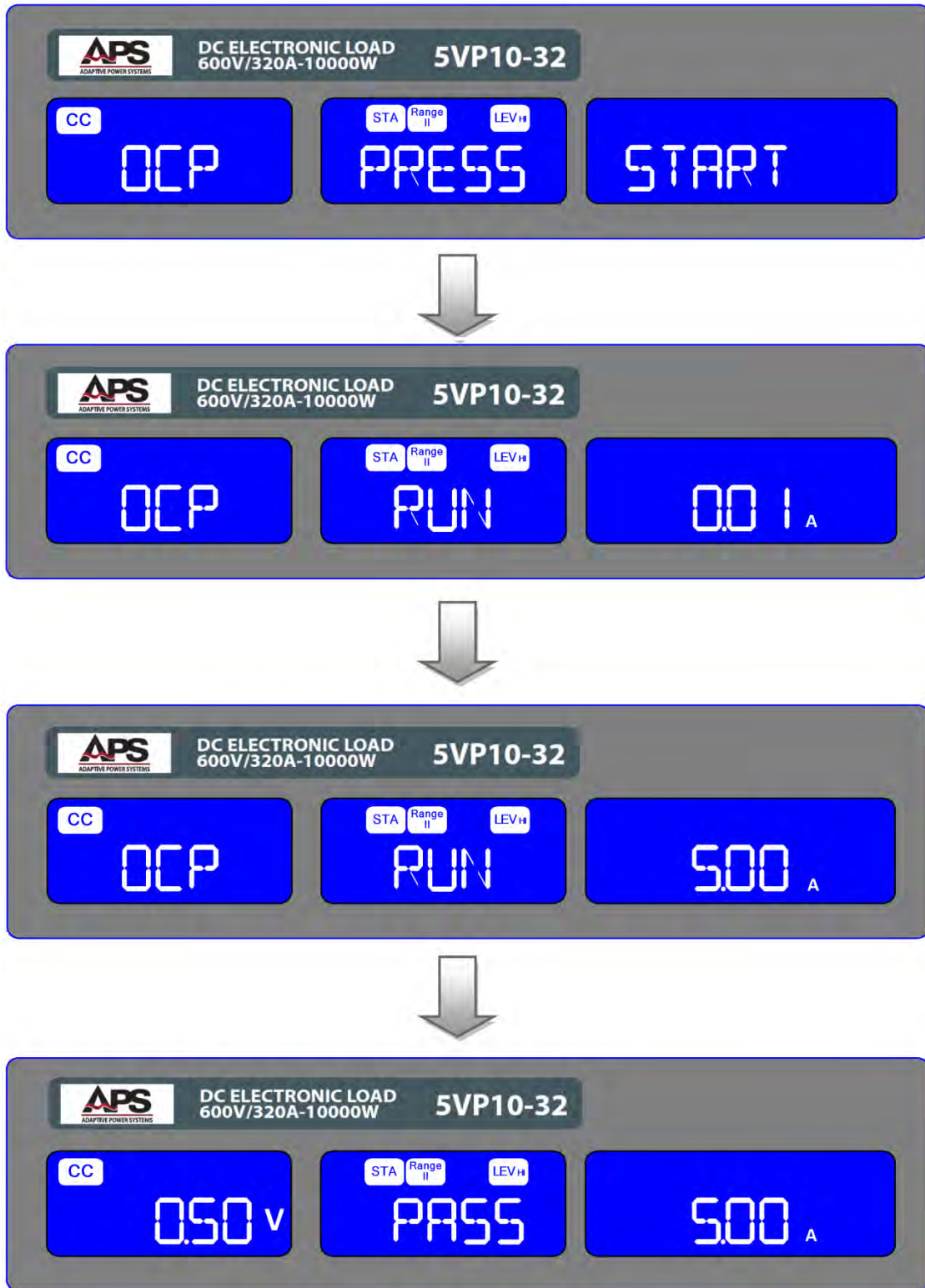

At the end of the test, the OCP test results in shown on the center LCD. The test passes (**PASS**) if:

- The EUT’s OCP trip point is between the lower end upper level current limit settings.
- The EUT’s output voltages drops below the voltage threshold when it trips on an overcurrent fault.

If either or both of these conditions were not met, the OCP result is **FAIL**.

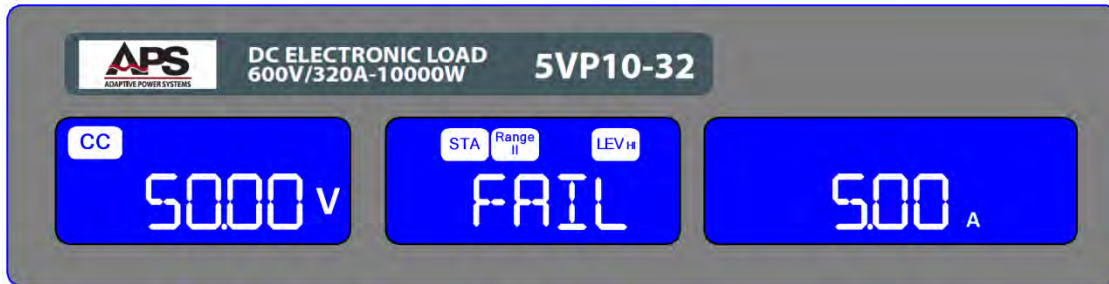

### 12.2.1 OCP Test – Remote Control

The parameters for the short, over power protection and over current protection tests can also be programmed over the optional computer interfaces.

To invoke over current protection circuit testing of a unit under test, send the following sequence of commands to the load:

This test will start sinking current at 3A and increase to 5A in 1A steps.

REMOTE	Set Remote
TCONFIG OCP	Set OCP test
OCP:START 3	Set start load current 3A
OCP:STEP 1	Set step load current 1A
OCP:STOP 5	Set stop load current 5A
VTH 0.6	Set OCP VTH 0.6V
IL 0	Set current low limit 0A
IH 5	Set current high limit 5A
NGENABLE ON	Set NG Enable ON
START	Start OCP testing
TESTING?	Ask Testing? 1:Testing, 0:Testing End
NG?	Ask PASS/FAIL?,0:PASS,1:FAIL
OCP?	Ask OCP current value
STOP	Stop OCP testing.

### 12.3 OPP Test Example

Following setting steps are required to set up and execute over power protection test mode.

Press the “Limit” key to set the upper and lower power limit for the EUT during over power conditions. The “W\_Hi” limit screen will be displayed. Set W\_Hi to 30W.

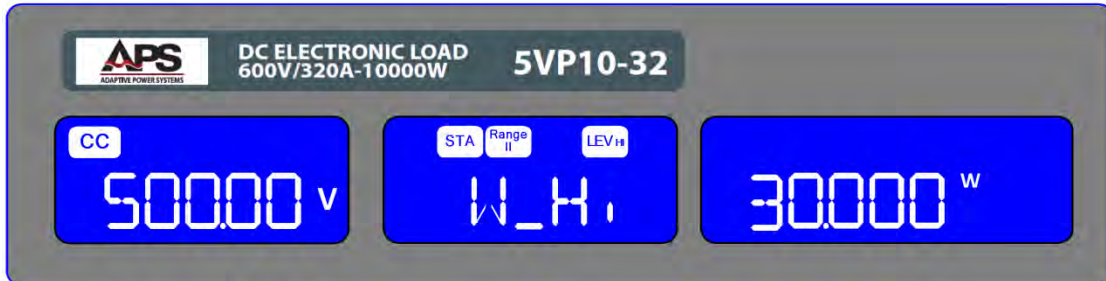

Press the “Limit” key again to set the lower power limit for the EUT during over power conditions. The “W\_Lo” limit screen will be displayed. Set W\_Lo to 0W as shown.

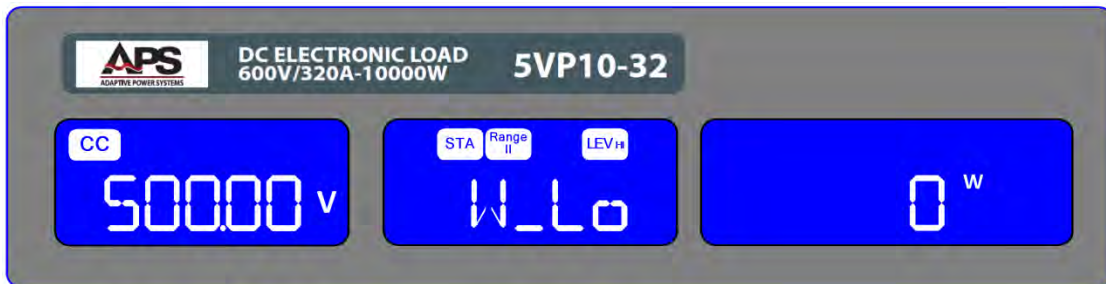

We are now ready to proceed to the OPP test mode. Press the “OPP” key to proceed to the OPP setup screen. “OPP-PRESS-START” will be displayed. Press the DOWN cursor key to enter the EDIT mode.



Set the starting power level “PSTAR” to 0W as shown below.



Press the DOWN cursor key to proceed to the “PSTEP” setup screen and enter 2W. The power will be increased in 2W steps.



Press the DOWN cursor key to proceed to the “PSTOP” setup screen and enter 100W as the final power test level. Once this setting is reached, the OPP test will end.



Press the DOWN cursor key to proceed to the “VTH” voltage threshold setup screen and enter 6.0Vdc as the voltage trip level as shown below.



This completes the OPP test setup. We are now ready to execute the test. Press the red “Start/Stop” button to enter TEST mode.

The test will run displaying the test power at each step. During the OPP test, the load monitors the EUT voltage to see if it drops below the VTH voltage threshold level.

OPP test screens during test execution are shown here:

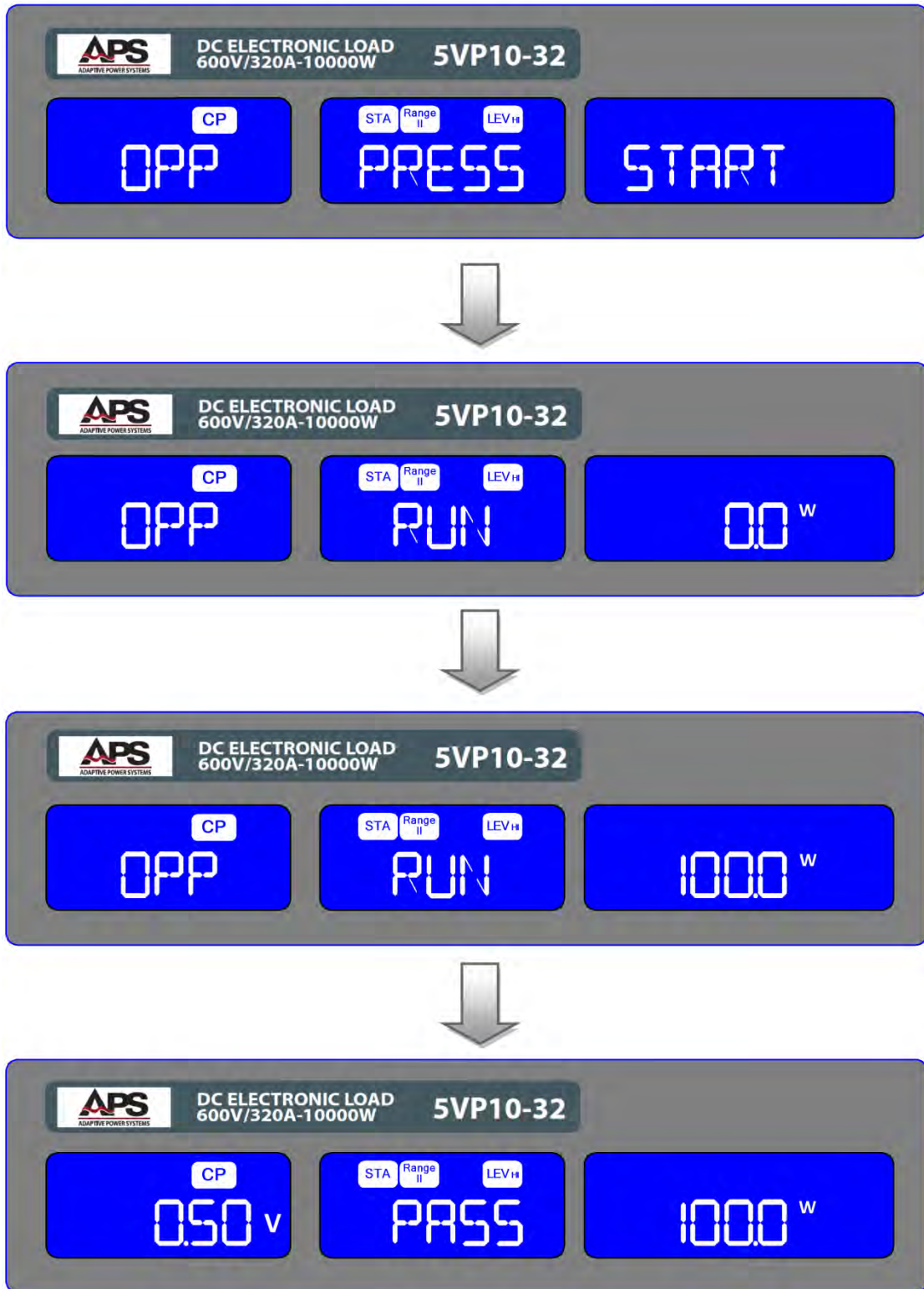

At the end of the test, the OPP test results in shown on the center LCD. The test passes (**PASS**) if:

- The EUT’s OPP trip point is between the lower end upper level power limit settings.
- The EUT’s output voltages drops below the voltage threshold when it trips on an overpower fault.

If either or both of these conditions were not met, the OPP result is **FAIL**.

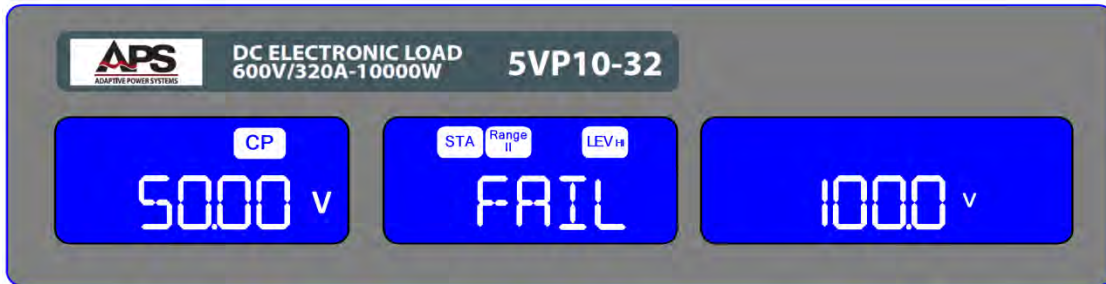

### 12.3.1 OPP Test – Remote Control

The parameters for the short, over power protection and over current protection tests can also be programmed over the optional computer interfaces.

To invoke over power protection circuit testing of a unit under test, send the following sequence of commands to the load:

In this example, threshold limits are set and the NG signal is enabled.

REMOTE	Set Remote	
TCONFIG OPP	Set OPP test	
OPP:START 3	Set start load watt 3W	
OPP:STEP 1	Set step load watt 1W	
OPP:STOP 5	Set stop load watt 5W	
VTH 0.6	Set OPP VTH 0.6V	
WL 0	Set watt low limit 0W	
WH 5	Set watt high limit 5W	
NGENABLE ON	Set NG Enable ON	
START	Start OPP testing	
TESTING?	Ask Testing?	1:Testing, 0:Testing End
NG?	Ask PASS/FAIL?	0:PASS,1:FAIL
OPP?	Ask OPP watt value	
STOP	Stop OPP testing	

## 12.4 SHORT Test Example

Following setting steps are required to set up and execute short circuit test mode.

Press the “**Short**” key to enter SHORT mode. The “**SHORT-PRESS-START**” screen will be displayed.



Press the UP cursor key to select the Short time setting screen. Default is 10,000 msec or 10 seconds but this value may be changed from this screen.



Press the “**Short**” key to proceed to the next setup screen. Next, press the DOWN cursor key to set the high voltage trip level to 1.0Vdc. Short test typically result in the EUT voltage collapsing to a near zero level.



Press the “**Short**” key to proceed to the next setup screen. Next, press the DOWN cursor key to set the low voltage trip level to 0.0Vdc.

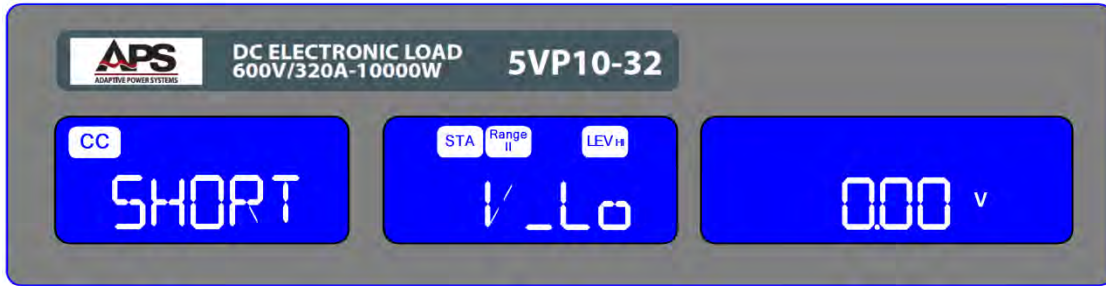

This completes the SHORT setup. To start the test, press the red “**Start/Stop**” key. The screen will return to the “**SHORT-PRESS-START**” setting.



Once the SHORT test completes, the result will be displayed in the center LCD and the right LCD will indicate the end of the test. If the EUT voltage remained between the V\_Hi and V\_Lo levels, the test result is **PASS**. If not, it will be **FAIL**.

**SHORT test PASS**



**SHORT test FAIL**

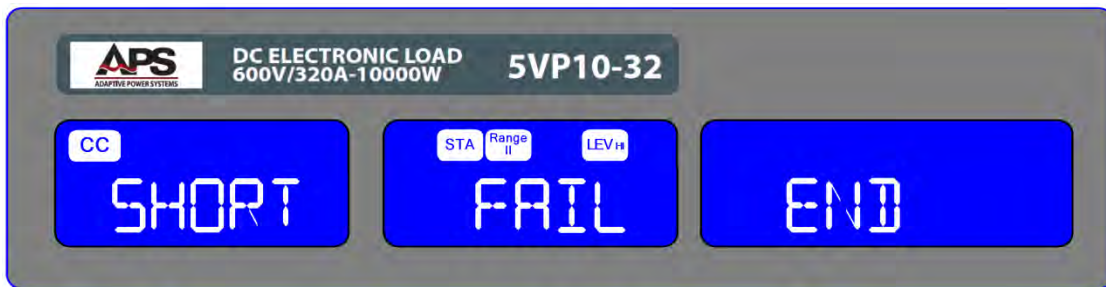

### 12.4.1 SHORT Test – Remote Control

The parameters for the short, over power protection and over current protection tests can also be programmed over the optional computer interfaces.

To invoke short circuit testing of a unit under test, send the following sequence of commands to the load:

This example sets a short test for 500ms until the STOP command is received.

REMOTE	Set Remote
TCONFIG SHORT	Set SHORT test function
STIME 500	Sets short time to 500ms time*
START	Start SHORT testing
TESTING?	Ask Testing?     1:Testing, 0:Testing End
STOP	Stop SHORT testing

\* if 500 is replaced with 0 the short test is continuous until STOP command

## 13 CE MARK Declaration of Conformity

**Directive:** 2004/108/EC

**Product Name** 5VP Series DC Electronic Loads Cabinets

**Serial Number** \_\_\_\_\_

**The manufacturer hereby declares that the products are in conformity with the following standards or other normative documents:**

**SAFETY:**

Standard applied IEC 61010-1:2001

**EMC:**

Standard applied EN 61326-1:2006

**Reference Basic Standards:**

**EMISSIONS:**

CISPR11: 2003+A1: 2004+A2: 2006  
EN 61000-3-2: 2006  
EN 61000-3-3: 2008

**IMMUNITY:**

IEC 61000-4-2: 2008  
IEC 61000-4-3: 2008  
IEC 61000-4-4: 2004 +Corr.1: 2006 +Corr.2: 2007  
IEC 61000-4-5: 2005  
IEC 61000-4-6: 2003+A1: 2004+A2: 2006  
IEC 61000-4-8: 2001  
IEC 61000-4-11: 2004

**Supplemental Information:**

**When and Where Issued:** March 28, 2014  
Irvine, California, USA

**Authorized Signatory** Loc Tran  
Quality Assurance Inspector  
Adaptive Power Systems

**Responsible Person** Joe Abranko  
Adaptive Power Systems  
17711 Fitch  
Irvine, California, 92649, USA



**Mark of Compliance**

## 14 RoHS Material Content Declaration

The table below shows where these substances may be found in the supply chain of APS's products, as of the date of sale of the relevant product. Note that some of the component types listed above may or may not be a part of the enclosed product.

Part Name	Hazardous Substance					
	<i>Pb</i>	<i>Hg</i>	<i>Cd</i>	<i>Cr6+</i>	<i>PBB</i>	<i>PBDE</i>
PCB Assy's	x	0	x	0	0	0
Electrical Parts not on PCB Assy's	x	0	x	0	0	0
Metal Parts	0	0	0	x	0	0
Plastic Parts	0	0	0	0	x	x
Wiring	x	0	0	0	0	0
Packaging	x	0	0	0	0	0

**Legend:**

0: Indicates that the concentration of the hazardous substance in all homogeneous materials in the parts is below the relevant RoHS threshold.

x: Indicates that the concentration of the hazardous substance of at least one of all homogeneous materials in the parts is above the relevant RoHS threshold.

**Notes:**

1. APS has not fully transitioned to lead-free solder assembly at this point in time. However, the vast majority of components used in production are RoHS compliant.
2. These APS products are labeled with an environmental-friendly usage period in years. The marked period is assumed under the operating environment specified in the product specifications.

Example of marking for a 10 year period.



## Index

<b>A</b>		<b>O</b>	
AC Input .....	40, 73	OCP test .....	182, 183, 214
Accessories .....	29	OPP test.....	183, 184, 218
<b>C</b>		<b>P</b>	
CC+CV mode.....	17	Parallel operation.....	161
Configuration.....	208	Programming.....	78, 83, 165, 167, 208
Connections .....	159	Protection.....	34, 153, 163, 164, 214, 218
Constant Current.....	15, 19, 28, 78, 81, 137, 138	<b>S</b>	
Constant Power .....	15, 16, 28, 78, 139	Series operation .....	161
Constant Resistance.....	15, 16, 138, 168	Short Test .....	221
Constant Voltage .....	15, 16, 139, 161, 162	Size 154	
Contact .....	10, 74, 76	Slew rate .....	20
Contents .....	3	Specifications.....	30, 81, 157
Cooling .....	40	State.....	177
CP+CV mode.....	18	<b>T</b>	
<b>F</b>		Terminals .....	154, 156
Features .....	28, 153, 163	Turn on.....	74
Frequency .....	20	<b>W</b>	
Fuse.....	72	Warranty .....	11
<b>G</b>		Waveform .....	20
Go/NoGo .....	137	Weight.....	41
<b>I</b>			
Installation .....	11, 71, 203, 206		





# **ADAPTIVE** Power Systems

Worldwide Supplier of Power Equipment

Copyright © 2014, Adaptive Power Systems, Inc. (APS) • All Rights Reserved • No reproduction without written authorization from APS.